



Pushing Performance
Since 1945

PEOPLE. POWER. PARTNERSHIP.

HARTING

User's Guide Termination Technologies

HARTING User's Guide Termination Technologies

All brand and product names are trademarks or registered trademarks of the owner concerned.

5th Edition 2023, revised 05/23

© HARTING Electric Stiftung & Co. KG, HARTING Electronics GmbH & Co. KG

Title: HARTING Stiftung & Co. KG, Espelkamp
Other figures – sources: HARTING Electric Stiftung & Co. KG
HARTING Electronics GmbH & Co. KG

HARTING Electric Stiftung & Co. KG | HARTING Electronics GmbH & Co. KG
Wilhelm-Harting-Str. 1 | Marienwerder Str. 3
32339 Espelkamp – Germany | 32339 Espelkamp – Germany
Phone +49 5772 47-0 | Phone +49 5772 4797200

Subject to alterations without notice

Printed in the Federal Republic of Germany

I. Preface

The right termination technique plays a crucial role in connecting devices, machinery and equipment reliably and efficiently. Innovative, quick-release connections ensure long-lasting flexibility and facilitate future-oriented modular structures. However, choosing the right connector requires detailed knowledge and practical experience. Which connector solution is right for my application? To help you answer this question, this small handbook has been prepared by specialists in the technical application of connectors at HARTING Technology Group.

The book should provide you with an overview of the range of connection technologies offered by HARTING and facilitate the assembly of components as well as the assembly or termination of HARTING connectors and contacts. It contains instructions on the proper and professional execution of terminations. It also provides the necessary criteria to check whether an interface is designed according to standards. The volume is structured by termination techniques, so that you can easily and quickly find the right solution for your application. *Italicised* terms are explained in the glossary.

The HARTING manual on termination techniques first appeared in 2008 under the title “Things to know about termination technologies for connectors”. The present version revises the edition of 2016/2017. The depth of revision differs from chapter to chapter and depends on the technical innovation and the changes in standards for the respective area. In particular, the chapters on crimping and insulation displacement connection (IDC) techniques reflect new developments. The Han® Push-In chapter is a completely new addition.

Norbert Gemmeke

Ralf Klein

Managing Director

Managing Director

HARTING Electric Stiftung & Co. KG

HARTING Electronics GmbH

General notice:

HARTING reserves the right to make construction changes in response to manufacturing requirements, improved quality or advances in the design. This product information describes the components but should not be considered as a guarantee of certain properties.

Table of contents

I. Preface	1
II. Protection against electric shock	9
1. Introduction.....	10
2. PE termination for connectors.....	11
3. Han-Modular®	12
4. Han® 7 D.....	15
5. Han-Snap®	15
6. Termination of PE wires.....	16
III. Screw termination technology.....	19
1. Introduction.....	20
2. Screw terminal types.....	20
3. Screw termination with/without wire protection.....	22
4. Advantages.....	22
5. Han® connectors with screw terminal technology.....	23
6. Screw terminals for high-current contacts	24
IV. Axial screw termination	27
1. Overview of the axial screw termination.....	28
2. Advantages.....	28
3. Application areas.....	29
4. Normative requirements: wire gauges.....	29
5. Stripping lengths, tightening torques, relevant series	30
6. Assembly.....	36
6.1 Tools	36
6.2 Notes on using the assembly tools	37
6.3 Assembly notes	38
6.4 Strain relief.....	39

6.5 Maintenance of axial screw connections	40
6.6 Correct positioning of the cable.....	40
7. Assembly of cables with large outer diameters	41
V. Crimp termination.....	45
1. Introduction.....	46
2. Features of the crimp contacts	47
3. Advantages of the crimp termination technique.....	47
4. Standards and guidelines for the crimping technology.....	48
4.1 Standard DIN EN 60352-2.....	49
4.2 Test for the wire pull-out forces	49
4.3 Assessment with the help of micro-sections.....	51
4.4 Measuring the crimp heights (open barrel crimping, B-form crimping).....	53
4.5 Visual inspection – position of the wire in the crimp contact	54
5. Overview of crimping tools (closed barrel crimping)	56
5.1 Manual crimping tools/machines according to cross-section	56
5.2 HARTING Crimping tools/dies and application areas	59
6. Crimping tools for DIN 41612/interface contacts (open crimping).....	66
7. Overview of stripping lengths and insulation diameters	69
8. Overview of crimping machines	70
8.1 Crimping machines for turned contacts.....	70
8.2 Crimping machines for reel-packaging contacts	72
9. Operating instructions for HARTING crimping tools	73
9.1 Double-Indent Crimping Tool 09 99 000 0888.....	73
9.2 HARTING Crimping tool 09 99 000 0110.....	81
9.3 Operating instructions for service crimping tool 09 99 000 0021	84
9.4 Operating instructions for crimping tool 09 99 000 0377	87
9.5 Battery crimping tool 09 99 000 0990	90
9.6 Crimping tool for D-Sub reel-packaged contacts 09 99 000 0169....	96
9.7 HARTING crimping tool 09 99 000 0620 for stamped contacts BC and FC according to DIN 41612.....	98

9.8 HARTING service crimping tool 09 99 000 0191 for FC individual contacts.....	100
9.9 Crimping tools for single contacts FC/BC and har -bus	102
9.10 Service Crimping Tool FC1/FC2/FC3 (09 99 000 0656)	105
10. Assembly and disassembly instructions.....	107
10.1 Assembly of contacts	107
10.2 Removal of contacts	108
VI. Cage-clamp termination.....	111
1. Introduction.....	112
2. Features	113
2.1 Cage-clamp termination technology: general information.....	113
2.2 Cage-clamp combined with press termination technique (Han® ES Press)	113
3. Cage-clamp terminals in HARTING products	114
4. Assembling the cable-clamp terminals.....	115
4.1 Standard cage-clamp contacts	115
4.2 Han® ES Press	117
4.3 Using ferrules	119
4.4 Possible assembly errors	119
5. Standards and guidelines	120
VII. Han® Push-In technology.....	121
1. Rapid termination technique	122
2. Termination details.....	122
3. Assembly.....	124
3.1 Assembly with stranded wires	124
3.2 Assembly with wire ferrules (insulated/uninsulated)	126
3.3 Assembly using solid wires	126

VIII. Han-Quick Lock®	127
1. Radial cage-clamp	128
2. Cage-clamp terminal and Han-Quick Lock®	128
3. Useable cable types	129
4. Advantages.....	130
5. Application areas.....	130
6. Normative requirements	131
7. Technical details.....	131
7.1 Stripping lengths, cable cross-sections	131
7.2 Micro-sections	132
8. Series with Han-Quick Lock®	133
9. Suitable tools	135
10. Assembly instructions	135
10.1 Assembly	135
10.2 Removal.....	136
IX. Solder termination technology	137
1. Introduction.....	138
2. Soldering method	139
2.1 Wave soldering.....	139
2.2 Reflow soldering	140
3. Soldering bath temperatures for wave soldering	141
4. Solder.....	141
5. Soldering profiles	142
6. HARTING THR/SMT.....	143
7. Standards.....	148
8. Product portfolio of HARTING connectors for soldering/THR/SMT	150
X. Wire wrap termination	153
1. Introduction.....	154
2. Wrap types	155
3. Tools for the wire wrap technique	156

XI. Insulation displacement termination technology.....	157
1. Introduction	158
1.1 Overview of the insulation displacement connection.....	158
1.2 Industrial connectors	159
2. Assembly instructions	160
2.1 Assembly instructions for Han® 3A with HARAX®	160
2.2 Assembly instructions for unshielded HARAX® M8/M12	161
2.3 Assembly instructions for shielded HARAX® M12.....	162
2.4 Assembly instructions for M12 Slim Design IDC.....	163
3. Interface connectors.....	169
3.1 D-Sub standard.....	169
3.2 SEK.....	169
3.3 DIN 41612 connectors	171
3.4 Tools for interface and DIN 41612 connectors	172
3.5 Ethernet interfaces	173
3.6 Assembly instructions for HARTING RJ Industrial® 10G IP65 / 67	178
3.7 preLink® RJ45/M12 connectors and sockets	187
3.8 HARTING ix Industrial®	190
4. Piercing termination technique	196
4.1 Piercing termination overview.....	196
4.2 Assembly instructions HARTING RJ Industrial® GigaLink Cat. 6 _A IP20	197

XII. Press-in termination.....	201
1. Introduction.....	202
2. Definition of press-in technology.....	202
3. Recommended hole layout on the circuit board.....	203
4. Press-in process.....	205
5. Press-in tools.....	208
6. Manual lever and pneumatic presses.....	210
7. Overview of HARTING connectors with press-in technology.....	212
8. Requirements for press-in technology.....	213
9. HARTING presses.....	213
10. Conclusion.....	214
XIII. Fibre optic termination.....	217
1. Introduction.....	218
2. Planning of optical transmission systems.....	219
2.1 Influencing factors.....	219
2.2 Calculation examples.....	221
3. Assembly of fibre optic connectors.....	223
3.1 F-SMA connector for 1 mm POF with 2.2 mm cable sheath.....	223
3.2 F-SMA connectors for 1 mm POF with 3.6 mm cable sheath.....	225
3.3 F-SMA connectors for 1 mm POF with 6 mm cable sheath.....	227
3.4 Quick-assembly connectors for 1 mm POF with 2.2 mm cable sheath.....	229
3.5 F-ST connectors for 1 mm POF with 2.2 mm cable sheath.....	230
3.6 FO cable end sleeve for 1 mm POF with 2.2 mm cable sheath.....	232
3.7 F-TNC connectors (female).....	234
3.8 F-TNC connector (male).....	236
3.9 F-ST connectors for glass fibre.....	238
3.10 SC contacts for glass fibre.....	240
3.11 LC contact for GI fibre and single-mode fibres.....	242

4. FO contacts.....	244
4.1 FO contacts for Han D® and Han DD® contact inserts.....	244
4.2 FO contacts for Han E® inserts	246
4.3 FO contacts for 1 mm POF in Han-Modular®	248
4.4 FO contacts for GI fibre in Han-Modular®	250
4.5 Han-Brid® FO contacts.....	252
5. Operating instructions of HARTING four-indent crimping tool for 1 mm POF contacts.....	253
6. Tool kit	256
6.1 POF assembly kit with optical measuring devices.....	256
6.2 FO measuring device kit	258
6.3 GI fibre assembly kit.....	259
7. Overview of assembly	262
XIV. Attachment.....	267
1. Glossary	268
2. Overview of standards.....	270

II. Protection against electric shock

Table of contents

1. Introduction	10
2. PE termination for connectors	11
3. Han-Modular®	12
4. Han® 7 D	15
5. Han-Snap®	15
6. Termination of PE wires	16

1. Introduction

A protective earth is a conductor that provides safety. The abbreviation for protective earth is PE. The function of the protective earth in electrical systems is to protect people and animals from dangerous shock hazard voltage and electric shock in case of a fault (e.g. failure of the insulation for the housing).

A protective earth is frequently routed in electric systems and cables. This is colloquially known as protective earth wire, protective earth, earth or earth connection.

The protective earth wire is attached so that an electrical connection between the outer metallic housings of electrical equipment and the earth is established.

If, in case of a fault, the electric supply voltage is routed to touchable conductive parts of electrical equipment, it must be ensured that the current runs through the protective earth so that the electrical equipment with the fault is isolated from the electrical voltage supply within a short time. Here, depending on the application, disconnection times between 0.1 and 5 seconds must be undershot. Disconnection occurs by an earth leakage circuit breaker or by overcurrent protection devices in case of correlating resistances in the wires and the earth connection.

A protective earth must be identifiable with the colour combination green/yellow. This colour combination can only be used for protective earth wires.

The respective equipment manufacturer (installer) or plant operator is always responsible for proper installation of the protective equipment in accordance with the applicable VDE regulations.

2. PE termination for connectors

To protect against electric shock, certain measures must be taken the essence of which are defined in the following standards/regulations:

- DIN EN 60 204-1
- DIN VDE 0100-410
- DIN EN 61 984

Notice:

The equipment manufacturer (installer) is fundamentally responsible for the proper, safe operation of the protective earth of an electrical installation!

HARTING inserts are designed for terminating the PE. With the standard inserts (Han D[®], Han DD[®], Han E[®], Han[®] EE, Han-Com[®]), termination is always done using a PE screw. The PE screw is located in the *PE panel* that is mounted at both ends of the contact insert. The fixing screws for assembly in the housing are the conductive connection between PE and the housing so that the housing is earthed.

The PE screw is mounted on the side where the contact chamber with the lowest number is (refer Figure II-1, below). This step is specified in DIN EN 175 301-801. This specification refers exclusively to the Han D[®] connector series, nevertheless all other non-standardised series such as Han E[®], Han[®] EE, Han[®] EEE and Han[®] DD are oriented to this specification. It should be noted that the PE screw on the Han[®] 15 D and Han[®] 25 D is not located on the side with the lowest contact number (refer Figure II-2). This exception is also regulated by DIN EN 175 301-801.

The inserts are equipped with two *PE panels*. The *PE panels* each contain two M3 fixing screws for assembly in the housing. They ensure the conductive connection between PE and housing. There is a thread in both *PE panels*

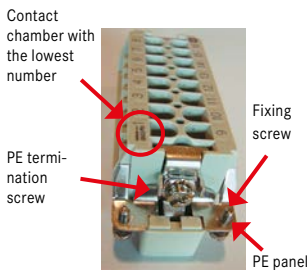


Figure II-1: PE termination for the Han[®] 16 E insert

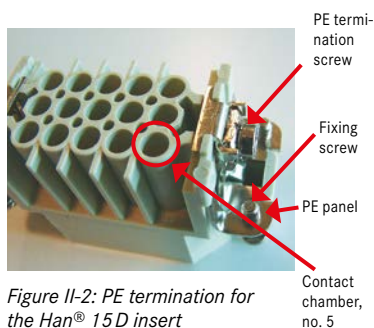


Figure II-2: PE termination for the Han[®] 15 D insert

for screwing in the PE clamping screw. These enable assembly of the shield frames and clamps.

Notice:

As long as the inserts remain unassembled, there is no conductive connection between PE panels. The connection is complete only after the insert has been mounted in the housing.

Bring the PE screw back into the original position (factory setting), if it has been unscrewed completely!

The following subchapters describe the processing of the PE in different HARTING products.

3. Han-Modular®

The modules of the Han-Modular® series are fitted in the *hinged frame*. Four fixing screws are used for assembling the *hinged frame* to the housing. There are two terminations for the protective earth: wire gauges of 4 – 6 mm² can be used on the power side (specified *tightening torque*: 1.2 Nm). For *stranded wires* with wire gauge 10 mm², the termination is only permitted if a *wire ferrule* is used, for example, with HARTING ferrule pliers 09 99 000 0374. On the control side, *wire gauges* from 1.0 to 2.5 mm² are possible, the specified *tightening torque* is 0.5 Nm (Figure II-3). A *wire ferrule* must be crimped on *stranded* and *fine stranded wires*.



Figure II-3: Hinged frame – termination sides

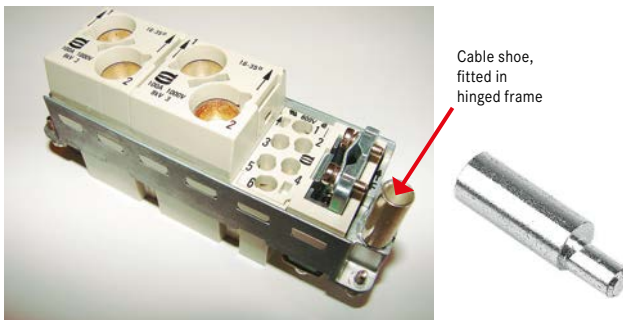


Figure II-4: Cable shoe termination to hinged frame

When using cable shoes, large wire gauges can be processed. HARTING has cable shoes for *wire cross-sections* of 16 mm² and 25 mm². Crimp the cable shoes with a crimping tool (e.g. K25 made by Klauke). The process and the result comply with DIN 46230, the standard that regulates crimping with pressing tools for non-insulated cable connections. You must then connect the cable shoe to the power side of the *hinged frame*.

Notice:

The use of cable shoes is only possible in bulkhead mounted housings and hoods that are tall sized.

For hoods with side entry, you must place the cable shoe on the opposite side of the cable entry!

For terminating the PE wires with even larger *wire gauges*, HARTING has developed the PE module (single module) and the 200 A PE double module. These modules allow the processing of *wire gauges* of 10 mm² – 70 mm². They are designed so that the housing is connected conductively to the PE via the *hinged frame*.



Figure II-5: 200 A PE module with crimp termination

The Han-Modular® PE module can be easily fitted in the *hinged frame* and provides a safe electrical connection between the PE contact, *hinged frame* and housing. The PE protective earth is leading and complies with IEC 61984.

In order to meet different requirements, the module comes in two different variants – with crimp and axial screw termination. Thanks to its quick and reproducible field wireability, the crimping technology is ideal for transportation applications, for example. Existing crimping tools can still be used, as the crimping zones in the PE module and power contacts are identical. The PE module with axial screw termination has the advantage that an expensive special tool is not required: A hexagonal *tightening torque* wrench is sufficient. Mechanical engineering is the preferred application area for the variant with axial screw termination technology.

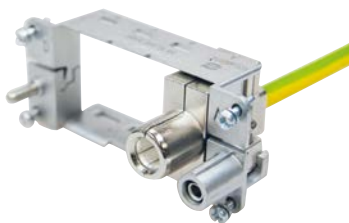


Figure II-6: PE module, fitted in the hinged frame

Table II-1: PE termination possibilities

Cross-section / wire gauge		Termination point	Termination type	Remarks
mm ²	AWG			
1 – 2.5	18 – 14	Hinged frame, control side	Screw	Use of ferrules that must be crimped before termination using ferrule pliers
4 – 6	12 – 10	Hinged frame, power side	Screw	
10	8	Hinged frame, power side	Screw	
16	6	Cable shoe, hinged frame, power side	Crimp, Screw	Only for hood, tall size and bulkhead mounted housing;
25	4	Cable shoe, hinged frame, power side	Crimp, Screw	Crimping with crimping pliers, K25 made by Klauke
10 – 35	8 – 2	PE module	Crimp, Axial screw termination	
25 – 70	4 – 00	200 A PE module	Axial screw termination	

4. Han® 7D

The inserts from the Han® 7D series are designed for rated voltages up to 250 V and rated currents up to 10 A. The insert has seven power contacts and a PE contact. For this application, however, it is inherent in the design that after assembly in the housing, there is no conductive connection between PE and the housing. According to EN 61984, however, for voltages greater than 50 V AC or 120 V DC, a connection between metallic housings and protective earth is required if the housing is not additionally insulated.



Figure II-7: Han® 7D inserts

In order to remain in compliance with standards, the insert is intended only for a plastic housing with size 3 A. The design does not allow for assembly in metal housings. Therefore, in case of a fault, the user is protected against touching any possibly live parts.

5. Han-Snap®

The holders for the Han Snap® series simplify the use of connectors in the electrical cabinet. Components made of plastic are used for areas of the housing that protect the inserts from external influences (this task is performed by the electrical cabinet) and for locking the top and bottom of the connector when plugged in. The parts are designed so that the connectors latch securely. With Han-Snap®, connectors can be used as panel feed throughs, as a “floating connection” or for snapping onto DIN rails.

Because Han-Snap® is made of plastic, pay particular attention to correct positioning when terminating the protective earth. Unlike metal housings, with Han-Snap® there is no conductive connection between the two *PE panels* of an insert.

HARTING inserts are equipped with a PE screw that has a defined position. If the PE is correctly terminated, this ensures that there is a conductive PE connection between upper and lower sections.

If you screw the PE screw into the wrong side of the insert, the PE connection at this point is interrupted even when plugged in, because there is no conductive connection between the *PE panels*. Figures II-8 to II-10 clarify the facts.

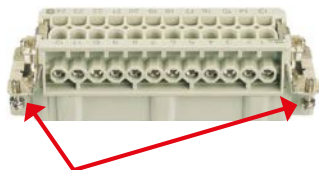


Figure II-8: Unmounted insert: The PE panels are not electrically connected to each other (refer to red arrows)

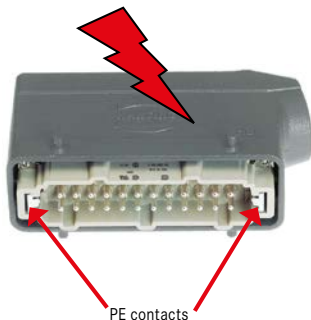


Figure II-9: Insert in the housing: There is a conductive connection between the PE panels via the housing

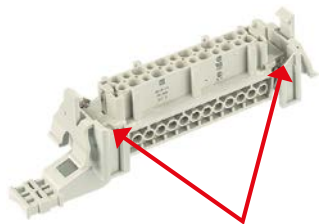


Figure II-10: Insert with Han-Snap®: The PE panels are not electrically connected to each other (refer to red arrows)

6. Termination of PE wires

The *cross-section* of the PE depends on the nominal *cross-section* of the current-carrying wires. The minimum *cross-section* of the protective earth is defined in EN 61984, Table 1. Table II-2 shows the content of the table in the standard.

Table II-2: Extract from EN 61984

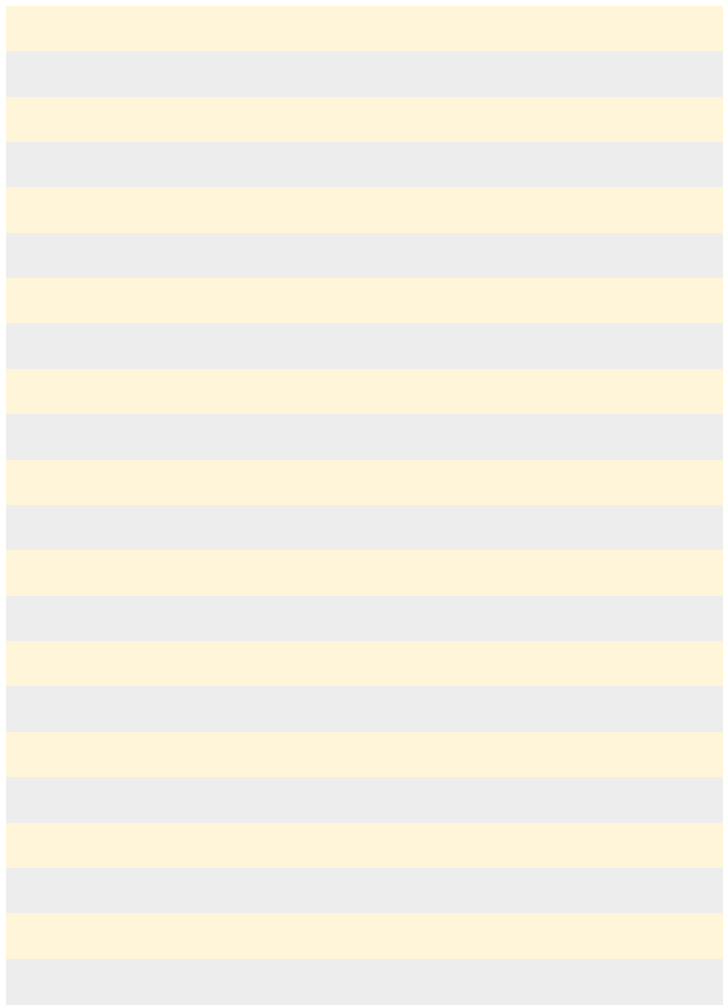
Nominal cross-section of the current-carrying wire mm ²	Minimum cross-section* of the protective earth and of touchable metal parts or covers that are not used as such mm ²	Minimum cross-section* of the connection between the protective earth and touchable metal parts or covers that are not used as such mm ²
Up to 1.5	According to the nominal <i>cross-section</i> of the current-carrying wire	
2.5	2.5	1.5
4	4	2.5
6	6	4
10	10	10
16, 25, 35	16	16

* Relating to the same material as the current-carrying wire

When terminating PE wires, a distinction is made between direct and indirect termination via cable shoes. With a direct termination, the size of the PE screw must be considered. So the maximum possible *cross-section* for M4 is 4 mm² and for M5 it is 6 mm². When termination is with cable shoes, the data in Table II-2 apply.

Notes

II



III. Screw termination technology

Table of contents

1. Introduction	20
2. Screw terminal types	20
3. Screw termination with/without wire protection	22
4. Advantages	22
5. Han® connectors with screw terminal technology	23
6. Screw terminals for high-current contacts	24

1. Introduction

In electrical engineering, a terminal is used to connect two electrical conductors. It provides a detachable connection for wires, conductors and cables. A mechanical screw or spring is used to secure the connected wire in the conductive chamber. The Han E[®] screw insert, shown below, is a classic example of screw termination technology within the Han[®] product portfolio.



Figure III-1: Han[®] 24 E insert with screw termination

The screw terminal is the oldest type of connection in the electrical industry. It is still widely used in the field because it provides a versatile, robust and safe electrical supply on-site.

2. Screw terminal types

HARTING uses two types of screw terminal:

- Classic screw terminal
- Axial screw terminal

The screw terminal can be operated using a conventional screwdriver. The operating principle corresponds to that of the well-known terminal block (*lustre terminal*). The screw is normally located next to the connection-side contact opening.

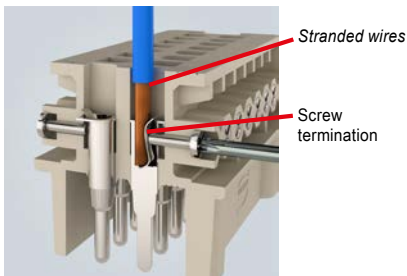


Figure III-2: Schematic view of a screw terminal

III

For establishing an axial screw contact, a hex (Allen) key is used from the side to turn the tapered screw located in the contact. The tapered screw presses the wire strands evenly against the contact wall (Figure III-3).

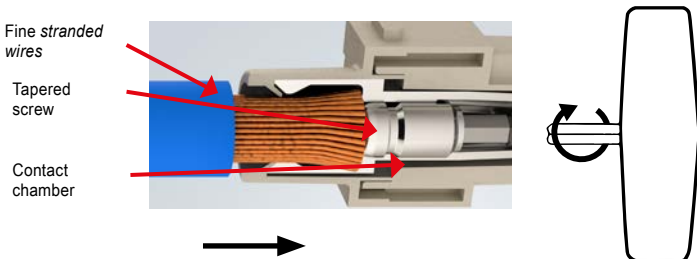


Figure III-3: Schematic view of a standard axial screw contact

DIN EN 60999 “Connecting Materials” defines and regulates these detachable connections. The standard is used as the basis for HARTING’s screw and axial termination technology.

The *pull-out force* is the main factor for determining the quality of a screw terminal. The *pull-out force* depends on the *cross-section* of the wire being connected, as defined in the following standards:

- DIN EN 60999-1: *Pull-out forces* for wires with *cross-sections* up to 35 mm²
- DIN EN 60999-2: *Pull-out forces* for wires with *cross-sections* from 35-300 mm²

For both types of terminating connections, no special tools or installation training for personnel are required.

3. Screw termination with/without wire protection

Screw terminals use a screw connection with or without wire protection. What is the task of this wire protection mechanism? The wire protection consists of a metal tongue; a screw terminal is used to press down on the wire (refer to Figure III-4). This prevents the wire strands from shearing off during the installation. Aside from stripping, the wire ends require no preparation.

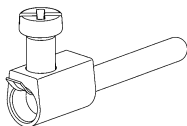


Figure III-4: Screw terminal with wire protection

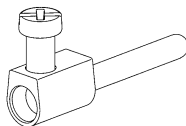


Figure III-5: Screw terminal without wire protection

There is no metal tongue when the screw terminal does not have the wire protection mechanism (refer to Figure III-5). So, for flexible *stranded wires*, *wire ferrules* must be attached to the wire ends. Rigid (solid) wires, when stripped to the proper length, can be used in both variants without any further processing.

4. Advantages

- + Easy handling
- + No special tools needed
- + Large *cross-section* range

5. Han® connectors with screw terminal technology

HARTING delivers the contact inserts listed below with screw termination technology:

Table III-1: An overview of HARTING contact inserts that use screw terminals

Series	Remarks
Han E® Han® HsB Han Hv E® Han® K 6/12 Han A® Han E® screw module (Han-Modular®)	With wire protection
Han® K 4/0 Han® K 4/2 Han® K 4/8 Han A®	Without wire protection

III

Another issue is the *tightening torque* of the screw, which is dependent on the size of the screw. The relevant requirements are specified in DIN EN 60 999. Table III-3 lists the *tightening torques*. The size of the corresponding screwdriver blade must also be taken into account.

Table III-2: Tightening and testing torques for screw terminals

Cross-section (mm ²)	1.5	2.5	4	6	10	16
Screw thread	M3	M3	M3.5	M4	M4	M6
Test tightening torque (Nm)	0.5	0.5	0.8	1.2	1.2	1.2*
Minimum pull-out force for stranded wire (N)	40	50	60	80	90	100

* For screws without heads

Table III-3: An overview of tightening torques and recommended screwdriver blade sizes

Screw size	Connector type	Tightening torque (Nm)	Recommended screwdriver blade
M3	Screw terminations Han® 3 A, 4 A, Q 5/0	0.25	0.4 x 2.5
M3	Screw terminations Han® 10 A – 32 A	0.50	0.5 x 3.5 or ± size 1
M3	Screw terminations Han E®, Han Hv E®, Han E® screw module Fastening screws (all sizes) Guide pins & sockets	0.50	0.5 x 3.5 or ± size 1 + 2
M4	PE terminals Han A®, Han E®, Han D®, Han DD® PE terminals K (8/24)	1.20	0.5 x 3.5 or ± size 1 + 2
M4	Screw terminations Han® HsB	1.20	0.8 x 4.5
M5	PE terminals Han® HsB Han® HsC (K 12/2), K 4/X, K 6/12	2	0.8 x 4.5 1.2 x 8

6. Screw terminals for high-current contacts

For high-current contacts, in addition to axial screw and crimp technology, screw terminals can also be used together with cable shoes: variants are available for the Han® HC Modular 350 contacts (for *cross-sections* up to 120 mm²) and the Han® HC Modular 650 contacts (for *cross-sections* up to 240 mm²). On the termination side, the sets consist of a washer, retention clip and hex screw (M10 for the HC 350 and M12 for the HC 650).

A cable shoe must be crimped on the stripped wire before the assembly. During the assembly, make sure that the components are put together in the correct order (refer to Figure III-6, right).

- ① Hex screw
- ② Retention clip
- ③ Washer
- ④ Cable shoe

If necessary, a second washer can be used in front of the cable shoe.

Hold the counter nut firmly using a wrench (as shown in Figure III-6). Use a SW 17 wrench for the Han® HC Modular 350 or SW 24 for the Han® HC Modular 650 to protect the contact against *tightening torque*.

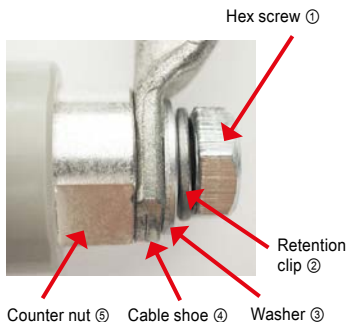
For both high-current contacts, Han® HC Modular 350 and 650, the recommended torque is exactly 14 Nm.

Notice:

The Han® HC Modular 350 / 650 HC contacts are intended for installation only in the Han® HPR bulkhead mounted housings!

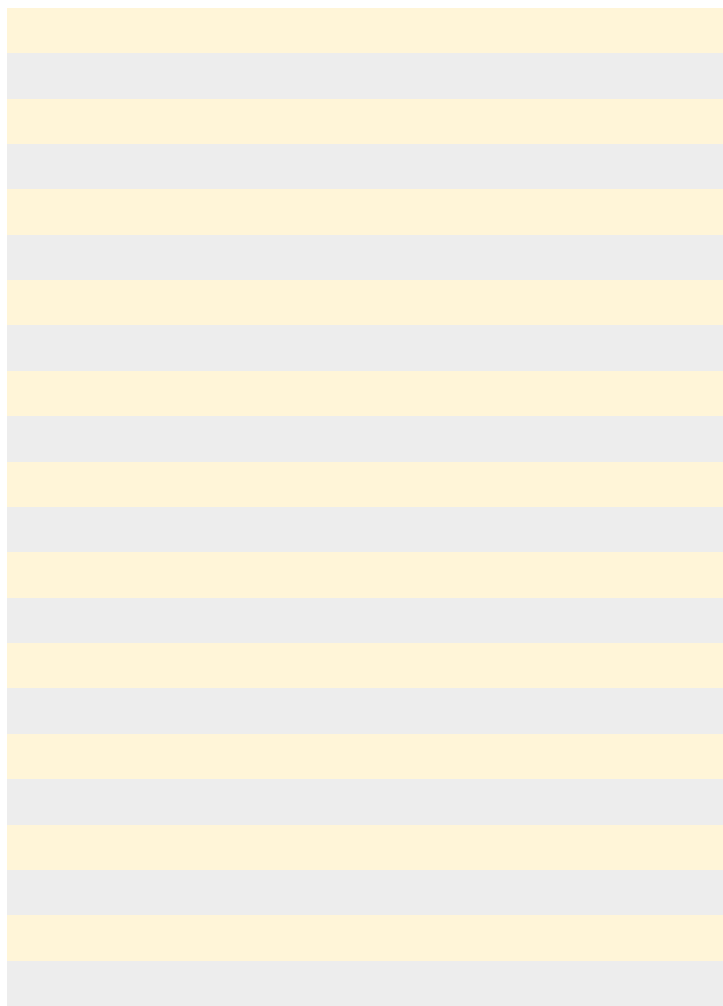


Figure III-6: Han® HC Modular high-current contact with contact shoe



Notes

III



IV. Axial screw termination

Table of contents

1. Overview of the axial screw termination	28
2. Advantages	28
3. Application areas	29
4. Normative requirements: wire gauges	29
5. Stripping lengths, tightening torques, relevant series	30
6. Assembly	36
6.1 Tools	36
6.2 Notes on using the assembly tools	37
6.3 Assembly notes.....	38
6.4 Strain relief	39
6.5 Maintenance of axial screw connections	40
6.6 Correct positioning of the cable.....	40
7. Assembly of cables with large outer diameters.....	41

1. Overview of the axial screw termination

The special feature of the axial screw termination is that the fixing screw for the cable is on a level axially with the contact and the cable. The cable is connected using a conical (axial) screw that penetrates axially into the *stranded wire* and pushes the single strands against the inside of the contact termination area until they are firmly clamped between the cone and contact termination area (see Figure IV-1).

The axial screw termination technology can be chosen for fine *stranded wires*. However, it was designed for a space-saving termination of wires with large wire gauges – without using any special tools. Wire gauges up to a maximum of 185 mm² can be processed. The termination is highly reliable. The technology is particularly insensitive to the impact of shock and vibration, which is an important criterion, for example, for the railway industry.

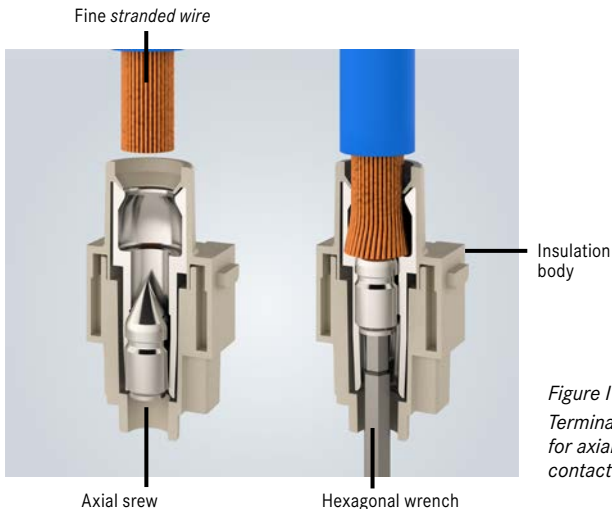


Figure IV-1:
Termination principle
for axial screw
contact

2. Advantages

- + Minimal space requirement
- + Easy handling
- + Large cross-section range
- + No special tools needed

3. Application areas

The axial screw termination is primarily for applications in the areas of transport technology, wind energy, power generation and distribution, mechanical engineering, robotics and automation technology, in which high currents between 40 and 650 amps are transmitted.

4. Normative requirements: wire gauges

IV

The axial screw technology is suitable for fine *stranded wires* in accordance with IEC 60228 Class 5 (refeTable IV-1, p. 30: Wire structure as per IEC 60228). Deviating cable designs must be tested separately. The specified wire gauges refer to the geometric *cross-section* of the cable being used. All data in the table is based on the catalogue “Industrial Connectors Han®”.

According to IEC 60228 concerning cables and insulated wires, a cable’s *cross-section* is determined by the conductivity (Ω/km) and the maximum wire diameter. A minimum wire diameter is not specified. In practice, this results in real *cross-sections* that can differ significantly from the nominal *cross-sections*, because manufacturers measure the resistance across the cable route (according to the standard).

Example: nominal *cross-section* = 35 mm² → real, geometric *cross-section* = 30 mm². Depending on the material quality, fluctuations occur in cross-sections that lead to different cables of the same nominal *cross-section* requiring different setting parameters or, in the worst case, the inability to process these with standard contacts and tools.

The geometric *cross-section* can be determined by the following formula: Cross section = number of single strands * 0.785 * diameter of single strand². Mathematically, the formula is:

$A = n * \pi * d^2/4$, where

A = *cross-section*

n = number of single strands

d = diameter of the single strand

The user can have the cable that he wants to use tested for termination possibilities before assembly. The HARTING laboratory “Corporate Technology Service” is available for the respective tests.

Table IV-1: Structure of wire strands, according to IEC 60228

Cross-section mm ²	Stranded wires IEC 60228 class 2	Fine stranded wires IEC 60228 Class 5	Super fine stranded wires IEC 60228 Class 6			
0.14			18 x 0.10	18 x 0.10	36 x 0.07	72 x 0.05
0.25		14 x 0.15	32 x 0.10	32 x 0.10	65 x 0.07	128 x 0.05
0.34		19 x 0.15	42 x 0.10	42 x 0.10	88 x 0.07	174 x 0.05
0.38		12 x 0.20	21 x 0.15	18 x 0.10	100 x 0.07	194 x 0.05
0.55	7 x 0.30	16 x 0.20	28 x 0.15	64 x 0.10	131 x 0.07	256 x 0.05
0.75	7 x 0.37	24 x 0.20	42 x 0.15	96 x 0.10	195 x 0.07	384 x 0.05
1.34	7 x 0.43	32 x 0.20	56 x 0.15	128 x 0.10	260 x 0.07	512 x 0.05
1.54	7 x 0.52	30 x 0.25	84 x 0.15	192 x 0.10	392 x 0.07	768 x 0.05
2.54	7 x 0.67	50 x 0.25	140 x 0.15	320 x 0.10	651 x 0.07	1280 x 0.05
4.34	7 x 0.85	56 x 0.30	224 x 0.15	512 x 0.10	1040 x 0.07	
6.34	7 x 1.05	84 x 0.30	192 x 0.20	768 x 0.10	1560 x 0.07	
10.34	7 x 1.35	80 x 0.40	320 x 0.20	1280 x 0.10	2600 x 0.07	
16.34	7 x 1.70	128 x 0.40	512 x 0.20	2048 x 0.10		
25.34	7 x 2.13	200 x 0.40	800 x 0.20	3200 x 0.10		
35.34	7 x 2.52	280 x 0.40	1120 x 0.20			
50.34	19 x 1.83	400 x 0.40	705 x 0.30			
70.34	19 x 2.17	356 x 0.50	990 x 0.30			
95.34	19 x 2.52	485 x 0.50	1340 x 0.30			
120.34	37 x 2.03	614 x 0.50	1690 x 0.30			
150.34	37 x 2.27	765 x 0.50	2123 x 0.30			
185.34	37 x 2.52	944 x 0.50	1470 x 0.40			
240.34	61 x 2.24	1225 x 0.50	1905 x 0.40			
300.34	61 x 2.50	1530 x 0.50	2385 x 0.40			
400.34	61 x 2.89	2035 x 0.50				
500.34	61 x 3.23	1768 x 0.60				

5. Stripping lengths, tightening torques, relevant series

Wires for connectors must be stripped to a certain length before assembly. Correct stripping fulfils the following functions:

- Maintaining the electrical dielectric strength. If the wire is stripped too short or too long, the overvoltage behaviour of the connector (e.g. the insert) changes and no longer meets the specifications. This can lead to damage in the application.
- Compliance with the maximum *contact resistance*
- Proper latching of contacts in the insert
- Securing the *current-carrying capacity*

Axial screws may also only be tightened to a specified *tightening torque* to comply with wire *pull-out* forces and contact *resistances* and to avoid damage to the wire. *Stripping lengths* and *tightening torques* for selected inserts and wire gauges can be found in Table IV-2, p. 32-35.

Table IV-2: Overview of contacts/inserts with axial screw termination

Insert	Wire gauge	Stripping length (mm)	Tightening torque (Nm)	Max. cable insulation diameter (mm)	Size of hexagon-socket (A/F)	Insert dimension for cable marking (mm)
	(mm ²)					
Han® K 4/4 finger safe	6 – 16	6 mm ² ; 11+1	2	8.9	2.5	7.4 PE: 8.9
		10 mm ² ; 11+1	3			
		16 mm ² ; 11+1	4			
		10 mm ² ; 11+1	3			
Han® K 4/4	10 – 22	16 mm ² ; 11+1	4	8.9 11	2.5	7.4 7.4 5.4 PE: 8.9
		22 mm ² ; 11+1	4			
		6 mm ² ; 11+1	2			
		10 mm ² ; 11+1	3			
Han® K 6/12	2.5 – 8	16 mm ² ; 11+1	4	6.2	2	7.4
		22 mm ² ; 13+1	4			
		2.5 mm ² ; 5+1	1.5			
		4 mm ² ; 5+1	1.5			
Han® K 6/6	6 – 10	6 mm ² ; 8+1	2	6.2	2	4.7
		8 mm ² ; 8+1	2			
		10 mm ² ; 8+1	2			
		10 mm ² ; 13±1	6			
Han® K 8/0	10 – 25	16 mm ² ; 13±1	6	11.4	4	4.9
		25 mm ² ; 13±1	7			
		16 mm ² ; 13±1	6			
		25 mm ² ; 13±1	7			
Han® K 8/0	16 – 35	35 mm ² ; 13±1	8	11.4	4	4.9
		10 mm ² ; 13±1	6			
		16 mm ² ; 13±1	6			
		25 mm ² ; 13±1	7			
Han® K 8/0	10 – 25	10 mm ² ; 13±1	6	11.4	4	4.75
		16 mm ² ; 13±1	6			
		25 mm ² ; 13±1	7			
		10 mm ² ; 13±1	6			

Table IV-2: Overview of contacts/inserts with axial screw termination

Insert	Wire gauge (mm ²)	Stripping length (mm)	Tightening torque (Nm)	Max. cable insulation diameter (mm)	Size of hexagon-socket (A/F)	Insert dimension for cable marking (mm)
Han® Q 2/0 Han® Q 2/0 High Voltage	2.5 – 10	2.5 mm ² : 8+1	2.5 mm ² : 1.8	7.3	2	5.6
		4 mm ² : 8+1	4 mm ² : 1.8			
		6 mm ² : 8+1	6 mm ² : 1.8			
		10 mm ² : 8+1	10 mm ² : 1.8			
Han® Q 4/2 Han® Q 4/2 with Han-Quick Lock®	4 – 10	4 mm ² : 8+1	4 mm ² : 1.8	7.3	2	5.6
		6 mm ² : 8+1	6 mm ² : 1.8			
		10 mm ² : 8+1	10 mm ² : 1.8			
		25 mm ² : 16	25 mm ² : 8			
Han® 200 A module Han® 200 A module with PE	25 – 40	40 mm ² : 16	40 mm ² : 8	12	5	0
		40 mm ² : 16	40 mm ² : 9			
		70 mm ² : 16	70 mm ² : 10			
		6 mm ² : 13±1	6 mm ² : 4			
Han® 100 A module	6 – 10	8 mm ² : 13±1	8 mm ² : 4	11.4	2.5	4.9
		10 mm ² : 13±1	10 mm ² : 4			
		10 mm ² : 13±1	10 mm ² : 6			
		16 mm ² : 13±1	16 mm ² : 6			
	10 – 25	25 mm ² : 13±1	25 mm ² : 7	11.4	4	4.9
		16 mm ² : 13±1	16 mm ² : 6			
		25 mm ² : 13±1	25 mm ² : 7			
		35 mm ² : 13±1	35 mm ² : 8			
16 – 35	38 mm ² : 13±1	38 mm ² : 8	11.4	4	4.9	
	6 mm ² : 11+1	6 mm ² : 2				
	10 mm ² : 11+1	10 mm ² : 3				
	16 mm ² : 11+1	16 mm ² : 4				
Han® 70 A module	14 – 22	14 mm ² : 12.5+1	14 mm ² : 4	10	2.5	5.9
		16 mm ² : 12.5+1	16 mm ² : 4			
		16 mm ² : 12.5+1	16 mm ² : 4			
		22 mm ² : 12.5+1	22 mm ² : 4			

Table IV-2: Overview of contacts/inserts with axial screw termination

Insert	Wire gauge	Stripping length (mm)	Tightening torque (Nm)	Max. cable insulation diameter (mm)	Size of hexagon-socket (A/F)	Insert dimension for cable marking (mm)
	(mm ²)					
Han® 40 A module	2.5 – 8	2.5 mm ² ; 5+1	1.5	4	2	4.7
		4 mm ² ; 5+1	2.5 mm ² ; 1.5	4		
	6 – 10	6 mm ² ; 8+1	2	6	2	4.7
		8 mm ² ; 11+1	2	10.5		
Han® C module with axial screw termination	2.5 – 8	2.5 mm ² ; 5+1	1.5	4	2	5.2
		4 mm ² ; 5+1	2.5 mm ² ; 1.5	4		
	6 – 10	6 mm ² ; 8+1	2	6	2	5.2
		8 mm ² ; 8+1	2	8.2		
Han® K 3/0 straight	25 – 40	25 mm ² ; 22	8	15	5	8.2
		40 mm ² ; 22	8	40		
	35 – 70	35 mm ² ; 22	8	15	5	8.2
		50 mm ² ; 22	9	50		
Han® K 3/0 angled	25 – 40	25 mm ² ; 22	8	15	5	9
		40 mm ² ; 22	8	40		
	35 – 70	35 mm ² ; 22	8	15	5	9
		50 mm ² ; 22	9	50		
Han® K 3/2 straight	35 – 70	35 mm ² ; 22	8	15	5	Power: 8.2 PE: 7.2
		50 mm ² ; 22	9	50		
	PE: 25 – 40	70 mm ² ; 22	10	70	5	Power: 15 PE: 10
		PE: 14	10	70		

Table IV-2: Overview of contacts/inserts with axial screw termination






Insert	Wire gauge (mm ²)	Stripping length (mm)		Tightening torque (Nm)		Max. cable insulation diameter (mm)	Size of hexagon-socket (A/F)	Insert dimension for cable marking (mm)	
		25 mm ² ; 40 mm ² ; PE:	22 14	25 mm ² ; 40 mm ² ;	8 8				
Han® K 3/2 angled	25 – 40 35 – 70 PE: 25 – 40	25 mm ² ; 40 mm ² ; PE:	22 14	25 mm ² ; 40 mm ² ;	8 8	Power: 15 PE: 10	5	Power: 9,0 PE: 7,2	
		35 mm ² ; 50 mm ² ; 70 mm ² ;	22 22 22	35 mm ² ; 50 mm ² ; 70 mm ² ;	8 9 10	Power: 15 PE: 10			Power: 9,0 PE: 7,2
Han® HC Modular 350	20 – 35 35 – 70 95 – 120	20 mm ² ; 35 mm ² ;	19+1 19+1	20 mm ² ; 35 mm ² ;	8 8	19.5	5	13	
		50 mm ² ; 70 mm ² ;	19+1 19+1	50 mm ² ; 70 mm ² ;	8 10 12	19.5			13
		95 mm ² ; 120 mm ² ;	19+1 19+1	95 mm ² ; 120 mm ² ;	14 16	19.5			13
PE contact for Han® HC Modular	35 – 70	35 mm ² ; 50 mm ² ; 70 mm ² ;	19+1 19+1 19+1	35 mm ² ; 50 mm ² ; 70 mm ² ;	8 10 12	-	5	-	
		60 mm ² ; 70 mm ² ;	23+2 23+2	60 mm ² ; 70 mm ² ;	12 12	27			28
Han® HC Modular 650	70 – 120	70 mm ² ; 95 mm ² ; 120 mm ² ;	23+2 23+2 23+2	70 mm ² ; 95 mm ² ; 120 mm ² ;	12 14 16	26.5	8	28	
		150 mm ² ; 185 mm ² ;	23+2 23+2	150 mm ² ; 185 mm ² ;	17 18	26.5			28

6. Assembly

A correct assembly of termination technology is important to guarantee that connectors meet the required specifications of an application. HARTING also offers the right tools for assembling connectors. They are perfectly adapted to the products and their characteristics and, if used correctly, ensure a consistently high build quality.

6.1 Tools

Table IV-3: Tools for applications of axial screw termination technology

Product	Features	Product photo
Hexagonal wrench for axial terminal screw		
Hexagonal wrench with tee handle 09 99 000 0313 09 99 000 0363 09 99 000 0364 09 99 000 0365	Suitable for... 40 A contacts (SW 2) 100 A contacts (SW 4) 200 A + 350 A contacts (SW 5) 650 A contacts (SW 8)	
Hexagonal wrench 1/4" bit 09 99 000 0369 09 99 000 0375	Suitable for... 40 A contacts (SW 2) 70 A contacts (SW 2.5)	
Hexagonal adapter 3/8" 09 99 000 0370 09 99 000 0371 09 99 000 0372	Suitable for... 100 A contacts (SW 4) 200 A + 350 A contacts (SW 5) 650 A contacts (SW 8)	
Torque set for high-current axial contact 09 99 000 0833	Suitable for... 100 A contacts (SW 4) 250 A - 350 A contacts (SW 5)	
Torque set for power contact 09 99 000 0834	Suitable for... 40 A contacts (SW 2) 70 A contacts (SW 2.5)	

6.2 Notes on using the assembly tools

Tighten the axial screw with a torque wrench. **Observe the *tightening torque specified in Table IV-2, p. 32-35!*** This is the only way to ensure a *gas-tight*, largely corrosion protected, connection of the copper strand and consistently good transmission properties throughout the entire working life of the connector.

Notice:

Use the hex key with T-handle supplied by HARTING only for pre-assembly of high-current contacts! For final assembly, you need a hexagon wrench with torque indicator.

Danger!

Danger to life due to electric shock if the wrong tool is used!

- ▶ Hex tools with ball head can damage the contact safety device of high-current contacts of the Han[®] HC Modular 350 and HC Modular 650 – refer to Figures IV-3 and IV-4.
- ▶ Use only hexagonal adapter with straight shape as shown in Figure IV-2!

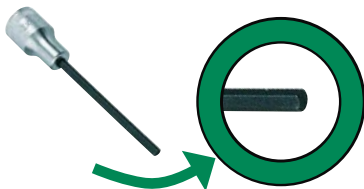


Figure IV-2: Hexagonal adapter, straight



Figure IV-3: Hexagonal adapter with ball head

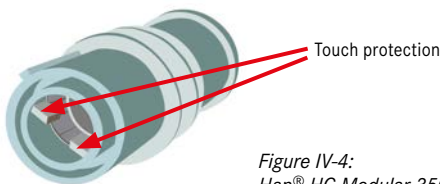


Figure IV-4:
Han[®] HC Modular 350 / 650

6.3 Assembly notes

The following applies to the axial screw termination technology – as for all other termination methods – clean and correct processing is important for the reliability of a connection. Table IV-2, p. 32-35, contains details on wire gauges, *stripping lengths* and required *tightening torques* for the listed inserts. The specified wire gauges refer to the *geometric cross-section* of the cable being used. The HARTING catalogue “Industrial Connectors Han®” is binding.

Assembly steps for terminating cables to contacts with the axial screw termination technique:

- ① Strip the *stranded wire* in accordance with the specified information (refer Table IV-2, p. 32-35) and do not twist the stripped ends.
- ② Make sure that the tapered screw in the contact is completely in the loosened position.
- ③ Push *stranded wire* all the way into the contact chamber and hold it firmly.

Notice:

If necessary, work with cable marking, as in Figure IV-7, p. 40.

- ④ Tighten the hexagon socket screw of the mating side using the proper torque wrench. The maximum *tightening torque*, according to Table IV-2, p. 32-35, depends on the wire gauge.
- ⑤ Avoid torsional stress and excessive bending of the *stranded wire* at the termination point!

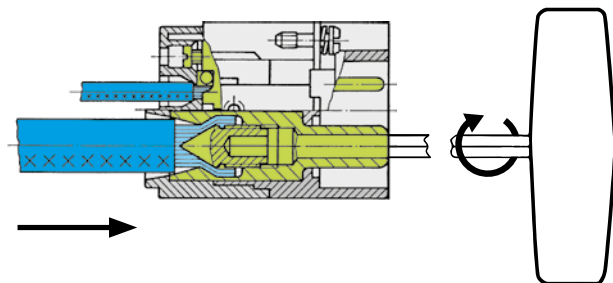


Figure IV-5: Termination principle for the axial screw termination technology

Notice:

Assembly instructions for axial screw technology in video format can be found under:
<http://www.harting.com/service/videos/video-presentationen/>

6.4 Strain relief

Connectors must be protected from harmful pulling and torsional forces. Pulling forces can be caused by pulling on the cable, but also by the weight of cable and connector. Torsional forces are resulting from twisting the cable. Both forces can impair the contact. Prevent damage by using cable clamps and fix the wires at a suitable distance from the termination point! Notes on correct execution are specified in DIN VDE 0100-520:2003-06 (refeTable IV-4):

Table IV-4: Maximum gap for the attachment of easily accessible wires
(DIN VDE 0100-520: 2003-06)

Outer diameter of the cable [mm]	Maximum gap for the fixing support [mm]	
	Horizontal (x)	Vertical (y)
$D \leq 9$	250	400
$9 < D < 15$	300	400
$15 < D < 20$	350	450
$20 < D < 40$	400	550

IV

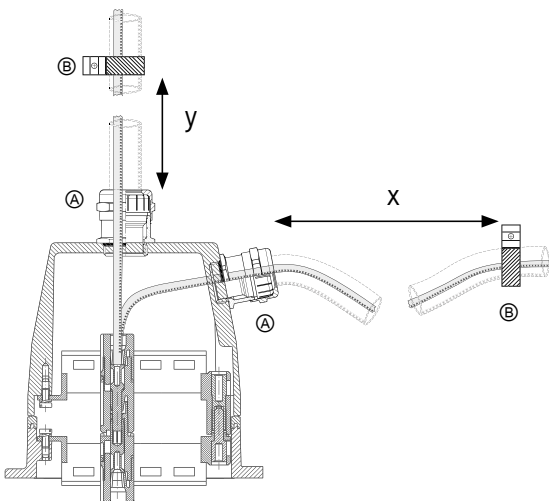


Figure IV-6: Strain relief using cable gland (A) and clamp (B)

6.5 Maintenance of axial screw connections

The transition between *stranded wire* and contact zone of the axial screw is critical to the quality of the connector. The *tightening torque* drives the axial screw against the *stranded wire* and pushes it in the clamping ring, so that an optimum transition is created (⇒ Figure IV-5, p. 38, and Chapter IV-5, p. 28).

Notice:

With multiple applications of the tightening torque, there is a danger that the stranded wires break between screw tip and clamping ring. The torque may therefore be applied only twice on the hexagon socket screw during the working life of an application: after assembly and one more time. Thereafter, the stranded wire must be shortened if necessary and re-stripped.

6.6 Correct positioning of the cable

To correctly enclose the axial screw by the *stranded wire*, the user must ensure that the cable to be connected is correctly positioned before tightening. Make a mark on the cable sheath: If the cable is pushed into the insert up to the marking (i.e. the marking is flush with the upper edge of the insert) then the cable is in the proper position and may be terminated.

Figure IV-7 illustrates this process using the example of the Han[®] HC Modular 350 contact. The marking and the upper edge of the insert are at the same level (as indicated by the red line).

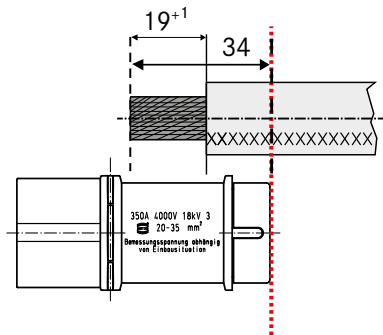


Figure IV-7: Use of the cable marking for cable termination

The dimensions for the marking on the cable sheath are shown in Table IV-2, p. 32-35.

7. Assembly of cables with large outer diameters



IV

Figure IV-8: Contacts from the Han® HC Modular 350 and 650 series

The Han® HC Modular 350 and Han® HC Modular 650 contacts are designed for use with cables that have a maximum permissible outside diameter of 19.5 mm and 26.5 mm. This ensures that the necessary creepage and clearance distances for the dielectric strength are adhered to. A shrink tube must be pulled over contacts and transitions to the cable to ensure proper functionality of the contacts even with cables whose outer diameter exceed the maximum permissible values.

There are two possibilities here:

- Shrinking the shrink tube over the contact and the previously inserted cable
- Shrinking the shrink tube over the prepared cable before termination to the contact

Both variants are described below. Depending on the design, one of the two methods can be advantageous with regard to assembly or pre-assembly by the user.

Shrink tube over contact and previously inserted cable

The following points should be observed for this type of assembly:

- ① Strip the cable according to Figure IV-9 and IV-10, so that the stripped *stranded wire* can be inserted fully into the contact.
- ② Terminate the cable to the torque specified for the wire gauge (refer to Table IV-2, p. 32-35):

Conductor	$\leq 35 \text{ mm}^2$	8 Nm
cross-section:	$\leq 50 \text{ mm}^2$	10 Nm
	$\leq 70 \text{ mm}^2$	12 Nm
	$\leq 95 \text{ mm}^2$	14 Nm
	$\leq 120 \text{ mm}^2$	16 Nm
	$\leq 150 \text{ mm}^2$	17 Nm
	$\leq 185 \text{ mm}^2$	18 Nm

- ③ Pull the shrink tube as shown in Figure IV-9 and IV-10 (red lines!) over the contact and shrink.

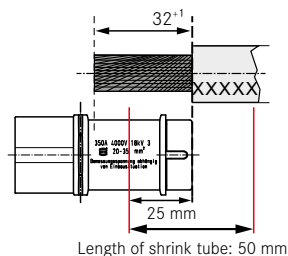


Figure IV-9: Shrink tube assembly over the cable and contact for Han® HC Modular 350

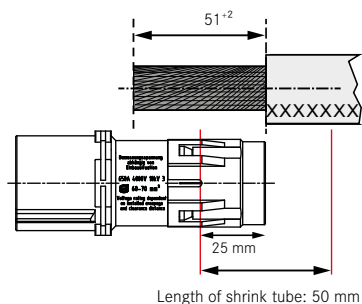


Figure IV-10: Shrink tube assembly over the cable and contact for Han® HC Modular 650

Shrink tube over the cable to be connected

The following points should be observed for this type of assembly:

- ① Strip the cable according to Figure IV-11 and Figure IV-12.
- ② The following points must be observed when applying the shrink tube directly on the cable:
 - Compliance with the specified *stripping length*
 - Compliance with the maximum permissible outer diameter of the cable to be connected
 - Special care when inserting the prepared cable into the contact chamber, because the *stranded wire* may possibly splay
- ③ Terminate the cable to the torque specified for the wire gauge (refer to Table IV-2, p. 32-35):

Conductor	≤ 35 mm ²	8 Nm
cross-section:	≤ 50 mm ²	10 Nm
	≤ 70 mm ²	12 Nm
	≤ 95 mm ²	14 Nm
	≤ 120 mm ²	16 Nm
	≤ 150 mm ²	17 Nm
	≤ 185 mm ²	18 Nm

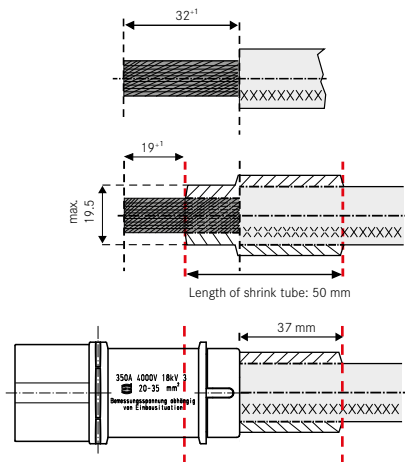


Figure IV-11: Shrink tube assembly over the cable for Han® HC Modular 350

V. Crimp termination

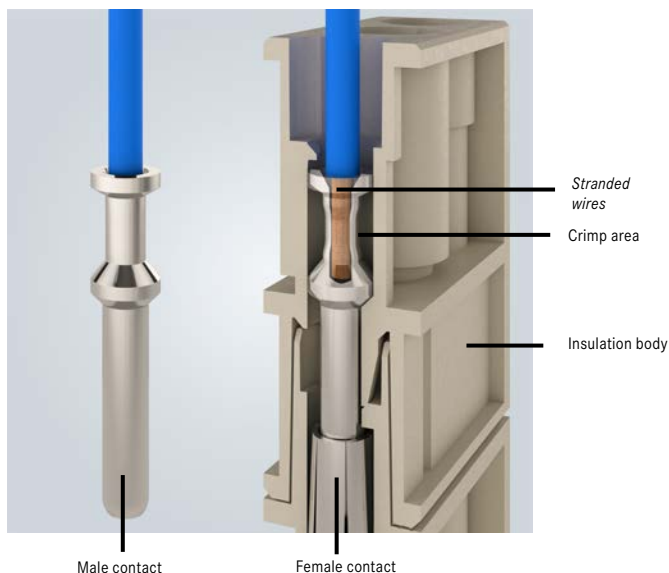
Table of contents

1. Introduction	46
2. Features of the crimp contacts	47
3. Advantages of the crimp termination technique	47
4. Standards and guidelines for the crimping technology	48
4.1 Standard DIN EN 60352-2	49
4.2 Test for the wire pull-out forces	49
4.3 Assessment with the help of micro-sections	51
4.4 Measuring the crimp heights (open barrel crimping, B-form crimping)	53
4.5 Visual inspection – position of the wire in the crimp contact	54
5. Overview of crimping tools (closed barrel crimping)	56
5.1 Manual crimping tools/machines according to cross-section	56
5.2 HARTING Crimping tools/dies and application areas	59
6. Crimping tools for DIN 41612/interface contacts (open crimping)	66
7. Overview of stripping lengths and insulation diameters	69
8. Overview of crimping machines	70
8.1 Crimping machines for turned contacts	70
8.2 Crimping machines for reel-packaging contacts	72
9. Operating instructions for HARTING crimping tools	73
9.1 Double-Indent Crimping Tool 09 99 000 0888	73
9.2 HARTING Crimping tool 09 99 000 0110	81
9.3 Operating instructions for service crimping tool 09 99 000 0021	84
9.4 Operating instructions for crimping tool 09 99 000 0377	87
9.5 Battery crimping tool 09 99 000 0990	90
9.6 Crimping tool for D-Sub reel-packaged contacts 09 99 000 0169	96
9.7 HARTING crimping tool 09 99 000 0620 for stamped contacts BC and FC according to DIN 41612	98
9.8 HARTING service crimping tool 09 99 000 0191 for FC individual contacts	100
9.9 Crimping tools for single contacts FC/BC and <i>har</i> -bus	102
9.10 Service Crimping Tool FC1/FC2/FC3 (09 99 000 0656)	105
10. Assembly and disassembly instructions	107
10.1 Assembly of contacts	107
10.2 Removal of contacts	108

1. Introduction

The requirements for electrical contacting are varied. In addition to the permanently good mechanical strength, low electrical *contact resistances* are important because they ensure low power dissipation and a low signal distortion based on the application. The material connection between crimp barrel and *stranded wire* is *gas-tight* (refer to Chapter V-3, p. 47), and must therefore be carried out very precisely and consistently. The goal is a consistent and reproducible quality. The termination type must also be efficient and economical, which is what the quantity-optimised HARTING tool solutions provide particularly well.

A professionally executed crimp connection meets these requirements. Appropriate processing tools are required for this; tools that, depending on the number and position in the process, can extend from the hand crimping tool to fully automatic crimping machines. This chapter explains what type of technical equipment is required, what the individual steps are and in particular how crimping itself works.



Termination principle of crimp technology

2. Features of the crimp contacts

Open and closed barrel crimping

Crimp terminals can be divided into open (punched rolled) and closed (turned) contacts (refer to *micro-sections* in Chapter V-4.3, pp. 52-53). Open crimp contacts are frequently used for applications in electronics with relatively low currents. They are offered mainly as linked reel packaging because the processed quantities are quite high. At higher currents, as often occurs in industrial applications with Han® connectors, individual turned contacts are used that allow a higher current load for the same *cross-section*.

Multiple strands in a crimp contact

You can crimp several *stranded wires* as required in one contact. When doing so, please notice the following:

- The *cross-section* of the crimp contact must be appropriate in relation to the total *cross-section* of the single strands.
- The *contact resistances* and *pull-out forces* defined in DIN EN 60352-2 must be met (refer to Table V-1, p. 50).
- According to IPC WHMA 620 D, it is permissible to use filler strands so that the crimp contact has a nominal cross-section.
- Be sure to maintain the creepage and clearance distances according to the relevant standards.

V

3. Advantages of the crimp termination technique

A perfectly crimped connection is both *gas-tight* and therefore corrosion-resistant. It performs just like a cold weld. The key criterion for a high-quality crimped connection is the mechanically firm seating achieved by the *stranded wire* within the contact's connecting element. It provides information about the quality of the crimp connection and determines the corrosion resistance of the connection.

The economic and technical advantages of the crimp termination technique are:

- *Gas-tightness:*

A *gas-tight* connection is characterised by a very strong compression between wire and crimp contact. The two components are deformed to such an extent that no or just minimal gaps remain (less than 10%). As a result, neither a liquid nor a gaseous medium can penetrate the crimp area. This effect prevents oxidation between the individual wires, and results in a constant *contact resistance*.

- Resistance to shock/vibration:
Even with recurring dynamical stress, the crimp connection ensures good contacting for a long time.
- Constant crimping quality thanks to high reproducibility:
Through the use of professional HARTING crimping tools, a high reproducibility of the crimping results is ensured. This leads to an excellent process reliability and guarantees a long working life of the crimp connection.
- Significantly higher wiring speed compared to other termination techniques:
The use of crimping machines allows a high level of automation in the wiring process, thus reducing manual operations. This increases the wiring speed and reduces labour costs per interface.
- Pre-assembly of cable harnesses with crimp contacts:
Through the option of pre-assembly, the location where the wire harness is produced can be separate from the location where it is assembled in the interface of the system.
- Compact, space-saving termination technique:
The crimp termination technique permits very high contact densities compared to, for example, the screw termination technique.

4. Standards and guidelines for the crimping technology

A properly executed crimp connection is characterised by a reproducible, constant quality in terms of its mechanical and electrical characteristics. That makes this termination technique particularly interesting for the production of large production series.

To achieve these high quality characteristics, there are various influencing factors to take into account. The following must be noted:

- Material of the contact material (elasticity, hardness, conductivity)
- Compliance of geometric *cross-sections* for the contact and wire
- Select the right crimping tool for the crimp contact being used
- Correct setting of the tools, checking for wear, regular maintenance
- Proper stripping of the *stranded wire*
- Use of suitable *stranded wire* (fine strand, class 5)

Moreover, there are significant test methods that are sound for assessing the quality of crimp connections.

- Measurement of the *pull-out force* of a crimp connection
- Analysis of the *cross-section*
- Measurement of the specified crimp heights or depths (only for open crimping)
- Visual inspection of the contact
- Determination of *contact resistance*
- Checking the *stripping length* and depth

4.1 Standard DIN EN 60352-2

Parameters and test criteria of a crimp connection that has been correctly executed according to the state-of-the-art are described in the above mentioned standard. In addition to testing possibilities that can be relatively easily performed by the user, it also describes more elaborate tests. These special inspection and test programs are relevant in particular for manufacturers and suppliers of various crimp components and must be carried out as release tests.

In general, users can be certain to create a professional, high-quality crimp connection when they process HARTING crimp contacts with the matching tool offered by HARTING. Additional requirements include matching the crimp contact and the *stranded wire* to each other and observing the corresponding assembly instructions.

In order to check and justify quality statements using simple and reliable criteria, you should observe DIN EN 60352-2 when crimping, which is clearly presented in the following section.

4.2 Test for the wire pull-out forces

Table V-1 contains the minimum requirements for the *pull-out forces* as a function of the *wire gauge* according to DIN EN 60352-2.

The test of wire *pull-out forces* as a destructive materials test allows an initial assessment of the quality of the crimp connection to be made. Because it is very simple, this test is frequently used directly for quality control in production. It only requires a so-called pull tester. In this test, the crimped contact including the wire is inserted and then the wire is pulled out of the contact. The device then displays the required *pull-out force*.

Table V-1: Overview of wire pull-out forces

Cross-section		Pull-out force
mm ²	AWG	N
0.05	30	6
0.08	28	11
0.12	26	15
0.14		18
0.22	24	28
0.25		32
0.32	22	40
0.50	20	60
0.75		85
0.82	18	90
1.0		108
1.3	16	135
1.5		150
2.1	14	200
2.5		230
3.3	12	275
4.0		310
5.3	10	355
6.0		360
8.4	8	370
10.0		380

Comments:

- For larger wire gauges, the requirements of the standards from NF F 61-030 (10 mm² - 70 mm²) and DIN EN 61238-1 (95 mm² - 240 mm²) apply depending on the *cross-section*.
- The *pull-out forces* specified in Table V-1 are, relative to the *wire cross-section*, the minimum tensile strength of a *stranded wire* in the crimp contact; they must be complied with in the tensile strength tests. If the required values are reached with the assembled crimp contacts, the tensile strength of the connection is to be considered flawless.
- 10 N corresponds to a force of approx. 1 kg.

Table V-2: Pull-out forces according to NF F 61-030 and DIN EN 61238-1

Cross-section		Pull-out force NF F 61-030	Pull-out force DIN EN 61238-1
mm ²	AWG	N	N
16.0	5	1,650	
25.0	4	2,300	
35.0	2	2,800	
50.0	1	3,300	
70.0	2/0	3,900	
95.0	3/0	-	5,400
120.0	4/0	-	7,200
150.0	-	-	9,000
185.0	-	-	11,100
240.0	-	-	14,400

V

4.3 Assessment with the help of micro-sections

A very good inspection comes from microscopic images of the polished cross-sectional area of the crimp zone. Here, the specimen is cut in the centre of the narrowest *cross-section*, polished and then etched.

The following pages show a properly crimped contact (Figure V-1, p. 52, and Figure V-5, p. 53, B-form/open barrel crimping) as well as typical failure patterns:

- Contact over-crimped with cracking of the contact barrel (Figure V-2)
- Unsymmetrical formation of the cross-sectional area (Figure V-3)
- Contact under-crimped: more than 10% air in the cross-section (Figure V-4)

Four-point crimping (closed barrel crimping)



V *Figure V-1: Micro-section of a flawless sample*

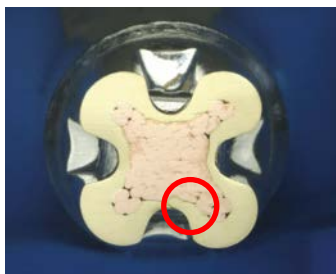


Figure V-2: Micro-section of a defective sample with cracks

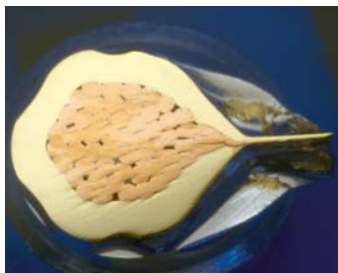


Figure V-3: Micro-section of a defective sample with cracks, extreme asymmetry



Figure V-4: Micro-section of a defective sample, wire cross-section too small

B-form crimping (open barrel crimping)



Figure V-5: Micro-section of a flawless sample

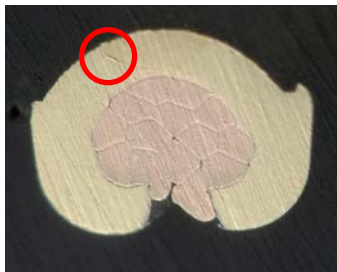


Figure V-6: Micro-section of a defective sample with cracks



Figure V-7: Micro-section of a defective sample, wire cross-section too small

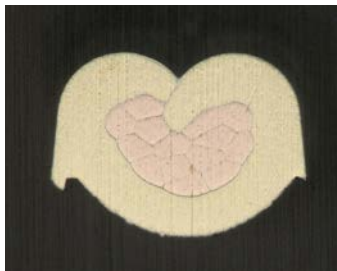


Figure V-8: Micro-section of a defective sample with cracks, unsymmetrical

4.4 Measuring the crimp heights (open barrel crimping, B-form crimping)

The crimp height is determined using a micrometer. The crimp contact is placed centrally between the measuring tips. The manufacturer of the contacts specifies the required crimp height. The correct setting of the tool can be seen in the measurement result.

V



Figure V-9: Micrometer screw



Figure V-10: Detail view of crimp contact



Figure V-11: Detail view of a crimp contact between the measuring tips

4.5 Visual inspection – position of the wire in the crimp contact

This test assesses the correct position of the *stranded wire* in contact and the state of contact after crimping. Section 16.4 of EN 60352-2 contains all

the required information for proper stripping. The required *stripping lengths* are specified by the contact manufacturer and must always be complied with.

The symmetry and exact position of the crimping and the general state of the contact (straight/bent) can be assessed visually. It is easier to evaluate open rolled, than turned closed contacts. In turned contacts, an inspection hole is, therefore, made, through which it is possible to detect if the *stranded wire* is at the bottom of the insertion hole. If the *stripping length* complies with the standard, the inspection hole of the contact is completely filled (refer to Figure V-12).



Figure V-12: Turned Han D® contact

- proper stripping (depth + length)
- inspection hole filled
- crimping is uniformly central

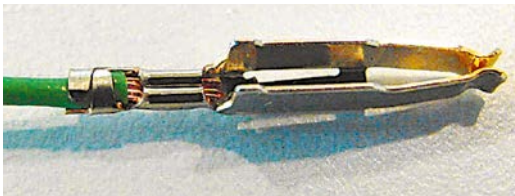


Figure V-13: Stamped FC contact

- proper stripping
- stranded wire positioned correctly
- insulation crimp enclosed correctly

5. Overview of crimping tools (closed barrel crimping)

We distinguish between the following series and power ranges:

Series	Max. rated current
• D-Sub	5 A (7.5 A for turned contacts)
• Han D®	10 A
• Han E®	16 A
• Han® C	40 A
• Han-Yellock®	20 A
• Han® TC	70-650 A

V 5.1 Manual crimping tools/machines according to cross-section

Tables V-3 to V-5, pp. 56-58, show which manual crimping tools and crimping machines are suitable for which contacts – depending on the *wire gauge*.

Table V-3: Overview of contacts D-Sub – manual crimping tools






Crimp terminals	Part number			mm ²	AWG	Crimping tool	Locator	Removal tool
	Male contacts	Female contacts	High-end female contacts					
						09 99 000 0501	09 99 000 0531	09 99 000 0368
D-Sub 09 67 000 ... 	3576	3476	3676	0.33-0.82	22-18	x	x	x
	8576	8476	8676	0.25-0.52	24-20	x	x	x
	5576	5476	5676	0.13-0.33	26-22	x	x	x
	7576	7476	7676	0.09-0.25	28-24	x	x	x



Figure V-14: Manual crimping tool 09 99 000 0501

Table V-4: Overview of Han® crimp contacts and manual crimping tools

Crimp terminals	Part number				mm ²	AWG	Crimping tools						Removal tools
	Male contact silver plated	Female contact silver plated	Male contact gold plated	Female contact gold plated			09 99 000 0888	09 99 000 1110	09 99 000 0021	09 99 000 0001	09 99 000 0377	09 99 000 0990 ¹⁾	
Han D® signal contacts 09 15 000 ... 	6107	6207	6127	6227	0.14-0.37	26-22	x						09 99 000 0012
	6104	6204	6124	6224			x	x	x				
	6103	6203	6123	6223	0.5	20	x	x	x	x	x		
	6105	6205	6125	6225	0.75	18	x	x	x	x	x		
	6102	6202	6122	6222	1.0	18	x	x	x	x	x		
	6101	6201	6121	6221	1.5	16	x	x	x	x	x		
	6106	6206	6126	6226	2.5	14	x			x			
Han D® FO contacts 20 10 001 ...	Male contact 3211 3212 / 3213		Female contact 3221 3222		1 mm POF							x	
Han E® power contacts 09 33 000 ... 	6127	6227	6117	6217	0.14-0.37	26-22	x			x			09 99 000 0319
	6121	6220	6122	6222	0.5	20	x	x	x	x	x		
	6114	6214	6115	6215	0.75	18	x	x	x	x	x		
	6105	6205	6118	6218	1.0	18	x	x	x	x	x		
	6104	6204	6116	6216	1.5	16	x	x	x	x	x		
	6102	6202	6123	6223	2.5	14	x	x	x	x	x		
	6106	6206			3.0	12	x	x		x	x		
	6107	6207	6119	6221	4.0	12	x	x		x	x		
Han E® F.O. contacts 20 10 001 ...	Male contact 3311		Female contact 3321		1 mm POF							x	
Han® C power contacts 09 32 000... 	6104	6204			1.5	16	x	x		x	x		09 99 000 0305 09 99 000 0381
	6105	6205			2.5	14	x	x		x	x		
	6107	6207			4.0	12	x	x		x	x		
	6108	6208			6.0	10				x	x ¹⁾		
	6109	6209			10.0	8				x	x ¹⁾		
Han-Yellock® power contacts 11 05 000 ... 	6101	6201	6121	6221	0.14-0.37	26-22	x		x				09 99 000 0319
	6102	6202	6122	6222	0.5	20	x	x	x	x			
	6103	6203	6123	6223	0.75	18	x	x	x	x			
	6104	6204	6124	6224	1.0	18	x	x	x	x			
	6105	6205	6125	6225	1.5	16	x	x	x	x			
	6106	6206	6126	6226	2.5	14	x	x	x	x			
	6107	6207	6127	6227	3.0	12	x	x		x			
	6108	6208	6128	6228	4.0	12	x	x		x			
Locator													
Han D®	09 99 000 0311									x			
Han E®	09 99 000 0310									x			
Han® C	09 99 000 0308									x			
Han-Yellock®	09 99 000 0342									x			
	09 99 000 0341										x		
	09 99 000 0343										x		
Han D®, Han E®, Han® C	09 99 000 0376										x		

Footnote:

¹⁾ Battery crimping tool; with the additional set 09 99 000 0995, Han® C contacts with conductor cross-sections of 6 and 10 mm² can also be processed.

Table V-5: Overview of crimp contacts and crimping machines

Crimp terminals series	Part number				mm ²	AWG	Crimping machines							
	Male contact silver plated	Female contact silver plated	Male contact gold plated	Female contact gold plated			09 99 000 0314	09 99 000 0307	09 98 000 6901 ¹⁾	09 98 000 6902 ¹⁾	09 98 000 6903 ¹⁾	09 98 000 6907 ¹⁾	09 98 000 9001	09 98 000 9002
Han D [®] signal contacts 09 15 000 ...	6107	6207	6127	6227	0.14-0.37	26-22	x	x ²⁾				x		
	6103	6203	6123	6223	0.5	20	x							
	6105	6205	6125	6225	0.75	18	x	x				x		
	6102	6202	6122	6222	1.0	18	x	x				x		
	6101	6201	6121	6221	1.5	16	x	x				x		
	6106	6206	6126	6226	2.5	14	x	x				x		
Han E [®] power contacts 09 33 000 ...	6127	6227	6117	6217	0.14-0.37	26-22	x		x ²⁾				x	
	6121	6220	6122	6222	0.5	20	x		x				x	
	6114	6214	6115	6215	0.75	18	x		x				x	
	6105	6205	6118	6218	1.0	18	x		x				x	
	6104	6204	6116	6216	1.5	16	x		x				x	
	6102	6202	6123	6223	2.5	14	x		x				x	
	6106	6206			3.0	12	x		x				x	
	6107	6207	6119	6221	4.0	12	x		x				x	
Han-Yellock [®] power contacts 11 05 000 ...	6101	6201	6121	6221	0.14-0.37	26-22						x		
	6102	6202	6122	6222	0.5	20						x		
	6103	6203	6123	6223	0.75	18						x		
	6104	6204	6124	6224	1.0	18						x		
	6105	6205	6125	6225	1.5	16						x		
	6106	6206	6126	6226	2.5	14						x		
	6107	6207	6127	6227	3.0	12						x ³⁾		
	6108	6208	6128	6228	4.0	12						x ³⁾		
Han [®] C power contacts 09 32 000 ...	6104	6204			1.5	16	x	x			x			x
	6105	6205			2.5	14	x	x			x			x
	6107	6207			4.0	12	x	x			x			x
	6108	6208			6.0	10			x		x			x
	6109	6209			10.0	8					x ⁴⁾			x

Footnotes:



- 1) To operate these interchangeable units, you need the TK-M basic unit 09 98 000 6900.
- 2) Depends on the stranded wire
- 3) Only with modification 09 98 557 6900
- 4) Only with modification 09 98 553 6900

5.2 HARTING Crimping tools/dies and application areas






The following table (⇒ Table V-6) indicates the types of contact and the tools/machines that are suitable for the listed crimping tools.

Table V-6: Crimping tools and accessories

Crimping tool	Application	Product photo
Hydraulic crimping tool with rechargeable battery 60 kN 09 99 000 0850	For processing TC 70 – TC 650 ($\leq 70 \text{ mm}^2$), together with 9 mm wide DIN 46235 crimping dies	
Manually operated hydraulic crimping tool 60 kN 09 99 000 0851	For processing TC 70 – TC 650 ($\leq 70 \text{ mm}^2$), together with 9 mm wide DIN 46235 crimping dies	
10 mm ² crimping die for 60 kN tool (D6) 09 99 000 0852	Fits to the tools 09 99 000 0850 and 09 99 000 0851	
16 mm ² crimping die for 60 kN tool (D8) 09 99 000 0853		
25 mm ² crimping die for 60 kN tool (D10) 09 99 000 0854		
35 mm ² crimping die for 60 kN tool (D12) 09 99 000 0855		
50 mm ² crimping die for 60 kN tool (D14) 09 99 000 0856		
70 mm ² crimping die for 60 kN tool (D16) 09 99 000 0857		
Hydraulic crimping tool with rechargeable battery 120 kN 09 99 000 0860	For processing TC 70 – TC 650 ($\leq 240 \text{ mm}^2$), together with DIN 46235 jaws	

Crimping tool	Application	Product photo
Manually operated hydraulic crimping tool, 120 kN 09 99 000 0861	For processing TC 70 – TC 650 ($\leq 240 \text{ mm}^2$), together with DIN 46235 jaws	
10 mm ² Crimping die for 120 kN tool (D6) 09 99 000 0862	Fits tools 09 99 000 0860 and 09 99 000 0861	
16 mm ² Crimping die for 120 kN tool (D8) 09 99 000 0863		
25 mm ² Crimping die for 120 kN tool (D10) 09 99 000 0864		
35 mm ² Crimping die for 120 kN tool (D12) 09 99 000 0865		
50 mm ² Crimping die for 120 kN tool (D14) 09 99 000 0866		
70 mm ² Crimping die for 120 kN tool (D16) 09 99 000 0867		
95 mm ² Crimping die for 120 kN tool (D16) 09 99 000 0868		
120 mm ² Crimping die for 120 kN tool (D16) 09 99 000 0869		
150 mm ² Crimping die for 120 kN tool (D18) 09 99 000 0870		
185 mm ² Crimping die for 120 kN tool (D25) 09 99 000 0871		
240 mm ² Crimping die for 120 kN tool (D28) 09 99 000 0872		

V

Crimping tool	Application	Product photo
Double-indent crimping tool 09990000888	For processing contacts Han [®] C, Han D [®] , Han E [®] and Han-Yellock [®]	
Hand crimping tool 09990000110	For processing contacts Han [®] C, Han D [®] , Han E [®] and Han-Yellock [®]	
Service crimping tool 09990000021	For processing contacts Han D [®] , Han E [®] and Han-Yellock [®]	
Crimping tool Han [®] C 09990000377	For processing contacts Han [®] C with diameters 4/6/10 mm ²	
Crimping tool with rechargeable battery (set) 09990000990 ¹⁾	For processing contacts Han [®] C, Han D [®] and Han E [®]	

Footnote:

- 1) The crimp die for processing Han[®] C contacts, 4 / 6 / 10 mm² (part no. 09 99 000 0995) is not included in the delivery ⇒ please order separately!

Han D® Crimp contacts (rated current: 10 A)

	Wire gauge (mm ²)	Part number	
		Male contacts	Female contacts
 silver plated	0.14-0.37	09 15 000 6104	09 15 000 6204
		09 15 000 6107	09 15 000 6207
	0.50	09 15 000 6103	09 15 000 6203
	0.75	09 15 000 6105	09 15 000 6205
	1.00	09 15 000 6102	09 15 000 6202
	1.50	09 15 000 6101	09 15 000 6201
 gold plated	0.14-0.37	09 15 000 6124	09 15 000 6224
		09 15 000 6123	09 15 000 6223
	0.50	09 15 000 6125	09 15 000 6225
	0.75	09 15 000 6122	09 15 000 6222
	1.00	09 15 000 6121	09 15 000 6221
	1.50	09 15 000 6126	09 15 000 6226

Dimensioned drawing (dimensions in mm)

Cross-section		Ø	Stripping length of the stranded wire
mm ²	AWG		
0.14-0.37	26-22	0.90 mm	8 mm
0.5	20	1.10 mm	8 mm
0.75	18	1.30 mm	8 mm
1.0	18	1.45 mm	8 mm
1.5	16	1.75 mm	8 mm
2.5	14	2.25 mm	6 mm

Han E® Crimp contacts (rated current: 16 A)

	Wire gauge (mm ²)	Part number	
		Male contacts	Female contacts
 silver plated	0.5	09 33 000 6121	09 33 000 6220
	0.75	09 33 000 6114	09 33 000 6214
	1.0	09 33 000 6105	09 33 000 6205
	1.5	09 33 000 6104	09 33 000 6204
	2.5	09 33 000 6102	09 33 000 6202
	3.0	09 33 000 6106	09 33 000 6206
 gold plated	0.5	09 33 000 6122	09 33 000 6222
	0.75	09 33 000 6115	09 33 000 6215
	1.0	09 33 000 6118	09 33 000 6218
	1.5	09 33 000 6116	09 33 000 6216
	2.5	09 33 000 6123	09 33 000 6223
	4.0	09 33 000 6119	09 33 000 6221

Dimensioned drawing (dimensions in mm)

Identification	Cross-section		Stripping length of the stranded wire
	mm ²	AWG	
No groove	0.50	20	7.5 mm
1 groove*	0.75	18	7.5 mm
1 groove	1.00	18	7.5 mm
2 grooves	1.50	16	7.5 mm
3 grooves	2.50	14	7.5 mm
Wide groove	3.00	12	7.5 mm
No groove	4.00	12	7.5 mm

* on the rear crimp collar

Dimensioned drawing (dimensions in mm)



Cross-section		Ø	Stripping length of the stranded wire
mm ²	AWG		
1.5	16	1.75 mm	9.5 mm
2.5	14	2.25 mm	9.5 mm
4.0	12	2.85 mm	9.5 mm
6.0	10	3.5 mm	9.5 mm
10.0	8	4.3 mm	15.0* mm

15 mm stripping length for cable ≥ 5.4 mm Ø
 18 mm stripping length for cable ≥ 6.4 mm Ø

Han C® crimp contacts (rated current: 40 A)

	Wire gauge (mm ²)	Part number	
		Male contacts	Female contacts
 silver plated	1.5	09 32 000 6104	09 32 000 6204
	2.5	09 32 000 6105	09 32 000 6205
	4.0	09 32 000 6107	09 32 000 6207
	6.0	09 32 000 6108	09 32 000 6208
	10.0	09 32 000 6109	09 32 000 6209

Table V-8: Han-Yellock® crimp contacts (rated current: 20 A)

	Cross-section	Part no. male contact
 silver plated	0.14 – 0.37	11 05 000 6101
	0.5	11 05 000 6102
	0.75	11 05 000 6103
	1	11 05 000 6104
	1.5	11 05 000 6105
	2.5	11 05 000 6106
	3	11 05 000 6107
	4	11 05 000 6108
 surface gold plated	0.14 – 0.37	11 05 000 6121
	0.5	11 05 000 6122
	0.75	11 05 000 6123
	1	11 05 000 6124
	1.5	11 05 000 6125
	2.5	11 05 000 6126
	3	11 05 000 6127
	4	11 05 000 6128

V

Table V-9: Stripping lengths for Han-Yellock® crimp contacts

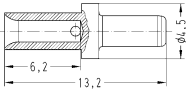
Cross-section		Stripping length of the stranded wire	Drawing
mm ²	AWG		
0.14 – 0.37	26-22	6.5 mm	
0.5	20	6.5 mm	
0.75	18	6.5 mm	
1	18	6.5 mm	
1.5	16	6.5 mm	
2.5	14	6.5 mm	
3	12	6.5 mm	
4	12	6.5 mm	

Table V-10: Han® TC crimp contacts







TC 70 	Cross-section	Part number	
		Male contact	Female contacts
	10	09 11 000 6131	09 11 000 6231
	16	09 11 000 6132	09 11 000 6232
	25	09 11 000 6133	09 11 000 6233
TC 100 	10	09 11 000 6114	09 11 000 6214
	16	09 11 000 6116	09 11 000 6216
	25	09 11 000 6125	09 11 000 6225
	35	09 11 000 6135	09 11 000 6235
TC 200 	25	09 11 000 6120	09 11 000 6220
	35	09 11 000 6121	09 11 000 6221
	50	09 11 000 6122	09 11 000 6222
	70	09 11 000 6123	09 11 000 6223
TC 250 	25	09 11 000 6126	09 11 000 6226
	35	09 11 000 6127	09 11 000 6227
	50	09 11 000 6128	09 11 000 6228
	70	09 11 000 6129	09 11 000 6229
TC 350 	25	09 11 000 6139	09 11 000 6239
	35	09 11 000 6140	09 11 000 6240
	50	09 11 000 6141	09 11 000 6241
	70	09 11 000 6142	09 11 000 6242
	95	09 11 000 6143	09 11 000 6243
	120	09 11 000 6144	09 11 000 6244
TC 650 	70	09 11 000 6161	09 11 000 6261
	95	09 11 000 6162	09 11 000 6262
	120	09 11 000 6163	09 11 000 6263
	150	09 11 000 6164	09 11 000 6264
	185	09 11 000 6165	09 11 000 6265
	240	09 11 000 6168	09 11 000 6268

Table VI-11: Wire gauges and stripping lengths of Han® TC crimp

Cross-section		Stripping length of the stranded wire
mm ²	AWG	
10	8	TC 70: 15.5 mm TC 100: 19 mm
16	6	TC 70: 15.5 mm TC 100: 19 mm TC 250: 22 mm
25	4	TC 70: 15.5 mm TC 100: 19 mm TC 200: 19 mm TC 250: 22 mm TC 350: 26 mm
35	2	TC 100: 19 mm TC 200: 20 mm TC 250: 22 mm TC 350: 26 mm
50	1	TC 200: 22.5 mm TC 250: 22 mm TC 350: 28 mm
70	2/0	TC 200: 22.5 mm TC 250: 22 mm TC 350: 28 mm TC 650: 42 mm
95	3/0	TC 350: 30 mm TC 650: 42 mm
120	4/0	TC 350: 24 mm TC 650: 42 mm
150	300 MCM	TC 650: 42 mm
185	350 MCM	TC 650: 42 mm
240	500 MCM	TC 650: 46 mm

6. Crimping tools for DIN 41612/interface contacts (open crimping)

There are two different manual crimping tools for the various open HARTING crimp contacts of the DIN 41612 and Interface series, one crimping tool for single contacts and one for reel-packaged contacts. The individual contacts are processed by inserting the crimp into the crimping die. The reel-packaged contacts are processed by manual operation of the indexing unit. The stripped *stranded wire* is positioned and the crimp zone is deformed symmetrically by squeezing the lever of the tool. During processing, the locator fixes the crimp contact between the crimping dies.

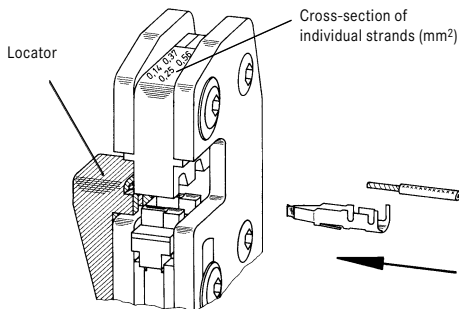


Figure V-15: Feeding of the contact



Figure V-16: Reel-package and individual contacts

Table V-12: Overview of manual crimping tools for D-Sub and DIN 41612 contacts (for footnotes ⇨ next page)

Crimp terminals series	mm ²	AWG	HARTING crimping tool for reels						HARTING crimping tool for individual contacts												
			09 99 000 0247	09 99 000 0119	09 99 000 0120	09 99 000 0248	09 99 000 0169	09 99 000 0597	Crimping die for 09 99 000 0620	Locator FC 09 99 000 0631	Locator BC 09 99 000 0630	09 99 000 0191 ¹⁾	09 99 000 0175	09 99 000 0596							
FC 1	09 06 000 7484	28 - 24																			
	09 06 000 7474	28 - 24	x																		
	09 06 000 8484	28 - 24	x																		
	09 06 000 8474	28 - 24																			
	09 06 000 9574	28 - 24																			
	09 06 000 9554	28 - 24																			
FC 2	09 06 000 7481	26 - 20																			
	09 06 000 7471	26 - 20		x																	
	09 06 000 8481	26 - 20		x																	
	09 06 000 8471	26 - 20																			
	09 06 000 5541	26 - 20																			
	09 06 000 9571	26 - 20																			
FC 3	09 06 000 9551	26 - 20																			
	09 06 000 7482	20 - 16																			
	09 06 000 7472	20 - 16																			
	09 06 000 8482	20 - 16																			
	09 06 000 8472	20 - 16																			
	09 06 000 5542	20 - 16																			
BC	09 06 000 9572	20 - 16																			
	09 06 000 9552	20 - 16																			
	09 02 000 8434	28 - 24																			
	09 02 000 8444	28 - 24																			
		28 - 24																			
		28 - 24																			

Footnotes: * = Crimp insert FC3 (0.75 - 1.50 mm²); ** = Crimp insert FC2 (0.25 - 0.56 mm²); *** = Crimp insert FC1 (0.14 - 0.25 mm²)¹⁾ Usage of this tool is restricted to cross-sections indicated in the table "Cross-section" on p. 100.


7. Overview of stripping lengths and insulation diameters

BC contacts acc. to DIN 41612


Table V-13: Overview of stripping lengths and insulation diameters for contact type BC

Cross-section		Insulation Ø mm
mm ²	AWG	
0.09 - 0.25	28 - 20	0.7 - 1.5
Stripping length of the stranded wire: 3.5 + 0.5 mm		

Contacts on a reel-package



Individual contacts

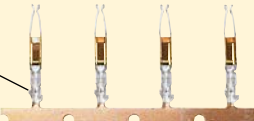


FC contacts acc. to DIN 41612


Table V-14: Overview of stripping lengths and insulation diameters for contact type FC

Cross-section		Insulation Ø mm	Identification
mm ²	AWG		
0.09 - 0.25	28 - 24	0.7 - 1.5	FC1
0.14 - 0.56	26 - 20	0.8 - 2.0	FC2
0.5 - 1.5	20 - 16	1.6 - 2.8	FC3
Stripping length of the stranded wire: 3.5 + 0.5 mm			

Contacts on a reel-package




Individual contacts



D-Sub contacts acc. to DIN 41652

Table V-15: Overview of stripping lengths and insulation diameters for contact D-Sub

Cross-section		Insulation Ø mm
mm ²	AWG	
0.09 - 0.25	28 - 24	max. 1.02
0.25 - 0.56	24 - 20	max. 1.52
Stripping length of the stranded wire: 2.5 + 0.5 mm		



Notice:

For D-Sub high density contacts and for special contacts with M form, refer to "HARTING Device Connectivity" catalogue.

8. Overview of crimping machines

HARTING offers crimping machines both for turned individual contacts as well as for stamped strip contacts. A distinction is made between semi- and fully automatic crimping machines. Users with a semi-automatic crimping machine must separately strip the cable during crimping, e.g. to a *stripping length* or using a hand tool. With crimping machines, the cable is stripped in one operation and crimped with the crimp contact.

8.1 Crimping machines for turned contacts

In addition to hand crimping tools, HARTING offers other tools for turned single contacts:

- a crimping machine
- a semi-automatic machine
- a pneumatic crimping tool

HARTING TK-M (crimping machine)

Features/benefits:

- Quick stripping and crimping in a single step
- Easy to operate thanks to well-arranged design and operation via touchscreen
- For loose, turned solid male and female contacts (for the HARTING series Han D[®], Han E[®])
- Optional processing of male and female contacts (wire gauges of 0.14 mm² to 6.0 mm², AWG 26 to AWG 10)
- Contact magazine with automatic level control
- *Gas-tight* crimped connection with a repeatable accuracy that ensures high quality
- Infinitely variable settings (stripping depth, *stripping length*, crimp depth and feed rate of the crimp contacts)
- Very low setup effort
- Low maintenance effort
- Work cycle: 1.5 s
- Crimp type: Four-mandrel double notch



Figure V-17: TK-M crimping machine
09 98 000 6900

HARTING TC-C01 (semi-automatic machine)

- Easy to operate thanks to well-arranged design
- Optional processing of HARTING male and female contacts (wire gauges of 0.14 mm² to 10.0 mm², AWG 22 to AWG 8)
- Automatic feeding of the contact
- *Gas-tight* crimped connection with a repeatable accuracy that ensures high quality
- Minimal setup effort
- Infinitely variable setting parameters (crimp depth and feed rate of the crimp contacts)
- Low follow-up costs for maintenance and repair
- Work cycle: 1 s
- Crimp type: Four-mandrel double notch



Figure V-18: Semi-automatic TC-C01

V

Pneumatic crimping tool with foot switch

- With the HARTING tools 09 99 000 0314 and 09 99 000 0307 you can use compressed air to crimp electrical contacts and conductors.
- Pneumatic crimping tools are an ideal way to get started with the power-assisted processing of crimped contacts in large numbers.
- Pneumatic crimping tools are easy to use. A foot switch that triggers the crimping process enables fast, consistent work sequences when crimping.
- With the appropriate locators and suitable crimp depth settings, you can process turned male and female contacts of the Han[®] C, Han D[®] and Han E[®] series.
- Optionally, accessories like foot switch 09 99 000 0347, table holder 09 99 000 0309 as well as different locators are available.



Figure V-19: Pneumatic crimping tool
09 99 000 0314

8.2 Crimping machines for reel-packaging contacts

BK crimping machine (fully automatic machine)

- Quick stripping and crimping in a single step
- Easy handling due to quick-change tool and stripper
- For HARTING crimp contacts D-Sub, FC, BC ...
- Optional use of male and female contacts
- Wire gauges of 0.09 mm² to 0.5 mm², AWG 28 to AWG 20
- Automatic extraction of insulation remnants
- Equipped with crimp force monitoring
- Setting parameters with notched rotary head (stripping depth, *stripping length*, wire crimp height, insulation crimp height, wire holder, reel-package indexing unit and positioning of the *stranded wire* in the crimp contact)
- Work cycle: 0.35 s



Figure V-18: TYPE BK crimping machine (fully automatic machine)

9. Operating instructions for HARTING crimping tools

9.1 Double-Indent Crimping Tool 09 99 000 0888

Usage and safety

HARTING's Double-Indent Crimping Tool 09 99 000 0888 (hereinafter referred to as the crimping tool) creates crimp connections between *stranded wires* and contacts for Han® industrial connectors. This crimping tool can be used to process unattached, machined, solid male and female contacts from the Han D®, Han E®, Han® C and Han-Yellock® series for wire *cross-sections* of 0.14 mm² to 4 mm² (AWG 26 to 12).

The crimping tool features a rotary locator used to properly position the crimping zone between the die jaws. These operating instructions list the settings parameters for the crimping depths (refer to table Settings for the crimping depth, p. 76); these can also be found directly on the locator. It is not necessary to check the crimping depth. The go/no-go gauge (09 99 000 0889) can be used to check the crimping tool.

The crimping tool may only be used when it is in proper technical condition. It may only be operated in a proper and safe manner. The manufacturer is precluded from liability for damages that result from unauthorised alterations or improper use of this tool.



*Double-Indent
Crimping Tool*





Included in delivery

- HARTING Double-Indent Crimping Tool with integrated rotary locator (as shown in the paragraph Design of the Double-Indent Crimping Tool, p.S. 74)
- Operating instructions

Usage: for contacts

The following contacts and *wire cross-sections* can be used with this crimping tool.

Contacts, part numbers and stripping lengths

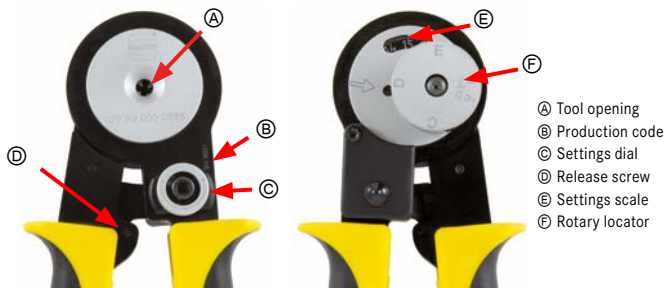
Han® C		Han D®***		Han E®		Han-Yellock®	
							
Part numbers*							
09 32 000 6xxx		09 15 000 6xxx		09 33 000 6xxx		11 05 000 6xxx	
Wire gauge							
(mm ²)	(AWG)	(mm ²)	(AWG)	(mm ²)	(AWG)	(mm ²)	(AWG)
1.5	16	0.14	26	0.14	26	0.14	26
to	to	to	to	to	to	to	to
4.0	12	2.5	14	4.0	12	4.0	12
Stripping length							
9.5 mm		8.0 mm**		7.5 mm		6.5 mm	

* For part numbers, refer to catalogue "HARTING Industrial Connectors Han®"

** 2.5 mm² = 6.0 mm

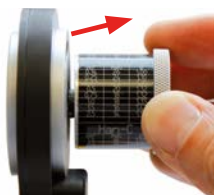
*** For 0.14 ... 0.37 mm², only 09 15 000 6107 / 6207 / 6127 / 6227 are applicable

Design of the Double-Indent Crimping Tool



Front side

Rear side



Specifying the locator position

Select the series to be processed – Han D®, Han E®, Han® C or Han-Yellock®. Pull the locator out of the latch and turn it until the required marking is lined up with the contact position.



The arrow **A** will indicate the selected marking. The locator will latch back into position when you release it.

V



Adjusting the crimping depth

In order to ensure the best error-free crimp connection, the crimping depth (the gap between the crimping dies) must properly correspond to the type of contact and wire diameter in use. The proper setting must be used. The respective setting can be found on the locator. You can also find it in the table Settings for the crimping depth, p. 76. Han-Yellock® 1.5 mm² e.g. corresponds to 1.30 mm crimping depth.

Settings for the crimping depth

Settings for the crimping depth

Contacts	mm ²	AWG	Crimping depth
Han D®	0.14	26	1.00
	0.25	24	1.10
	0.37	22	1.20
	0.5	20	1.32
	0.75	18	1.32
	1.0	18	1.35
	1.5	16	1.47
	2.5	14	1.50
Han E®	0.14	26	1.00
	0.25	24	1.00
	0.37	22	1.05
	0.5	20	1.36
	0.75	18	1.36
	1.0	18	1.36
	1.5	16	1.50
	2.5	14	1.60
	3.0	12	1.70
4.0	12	1.80	
Han® C	1.5	16	1.40
	2.5	14	1.50
	4.0	12	1.75
Han-Yellok®*	0.14	26	1.00
	0.25	24	1.00
	0.37	22	1.05
	0.5	20	1.10
	0.75	18	1.20
	1.0	18	1.20
	1.5	16	1.30
	2.5	14	1.55
	3.0	12	1.70
4.0	12	1.80	

* In combination with the Han-Yellok® male and female contacts, different locator settings should be used.

Preparing the crimping tool

NOTICE

Protect against unintentional adjustments

This crimping tool features a settings dial **A** which ensures that the crimping depth cannot be re-adjusted unintentionally. There is no need to set the crimping depth with a plug gauge. When necessary, you may use a go/no-go gauge (09 99 000 0889) to check that the crimping tool is functioning properly.



1. Open the crimping tool.



2. Unlatch the settings dial (pull it out) and then turn it until the desired number is visible in the scale on the back of the crimping tool **B**. Release the settings dial; give it a brief turn so that it latches back into place.

- ▶ The HARTING Double-Indent Crimping Tool has now been set and is ready for use with the selected contacts and wires!

Crimping



1. Insert the crimp contact into the tool opening ①. The locator ensures that the crimp contact is automatically positioned in the proper crimping position.



2. Insert a properly stripped wire into the crimp contact ②.



3. Press the crimping tool's handles together in order to crimp the contact. Press the handles closed until they automatically reopen (refer also to the chapter Ratchet lock, p. 79).



4. Remove the crimped contact.

NOTICE

Checking that the crimp is safe

You should visually inspect each crimp after it has been completed. Check for the proper *stripping length*, external damage, cracks etc.



Ratchet lock

The HARTING Double-Indent Crimping Tool 09 99 000 0888 features a ratchet lock **A** for ensuring that each crimp contact is produced with consistent quality.

This ratchet lock prevents the crimping tool from being opened prematurely during the crimping process. This ensures a consistent high-quality crimp!

Early Release

In the event of an operational error, it is possible to release the crimping tool before it has completed the crimp.



- Release the pressure off the ratchet by pressing gently on the tool's handles.
- Using a screwdriver, turn the unlocking screw **B** counter-clockwise.

Operational errors can happen when the contact is inserted incorrectly or when the wrong contact type is used.

NOTICE

Opening and releasing in the event of an operational error

Never open or close the Double-Indent Crimping Tool with force! Otherwise you endanger the functionality of the crimping tool.

Maintenance

We recommend regularly lubricating all movable parts with an all-purpose oil (e.g. SAE 30 W); this will ensure that your tool has a long service life.

Checking with the go/no-go gauge



Ⓐ



Ⓑ

1. Open the crimping tool as shown in chapter Preparing the crimping tool, p. S. 77).
2. Pull-out the settings dial and turn it until the scale on the back of the crimping tools shows the number 1.5. Release the settings dial; give it a brief turn so that it latches back into place. Release the settings dial; give it a brief turn so that it latches back into place.

3. Check the dimensions of the profile by inserting the go/no-go gauge (Ⓐ = front, Ⓑ = back) into the opening!

- It should be possible to insert the “Go” side Ⓒ; it should not be possible to insert the “No-go” side Ⓓ.



Your crimping tool must be re-adjusted by a trained technician, if it does not pass this test!

Accessories for the Double-Ident Crimping Tool

Accessories	
Designation	Part number
Replacement locator	09 99 000 0887
Go/no-go gauge	09 99 000 0889

9.2 HARTING Crimping tool 09 99 000 0110

Operating instructions

The HARTING Crimp Tool 09 99 000 0110 is designed to crimp solid turned HARTING Han D[®], Han E[®], Han[®] C and Han-Yellock[®] male and female contacts with wire gauges of 0.14 - 4 mm² (AWG 26 - AWG 12). The crimp tool is equipped with a multi-functional locator which allows for an easy and safe handling.



Products included in delivery

- HARTING Crimp tool (including locator)
- Instruction manual

The following crimp contacts (mm² / American Wire Gauge) can be handled:

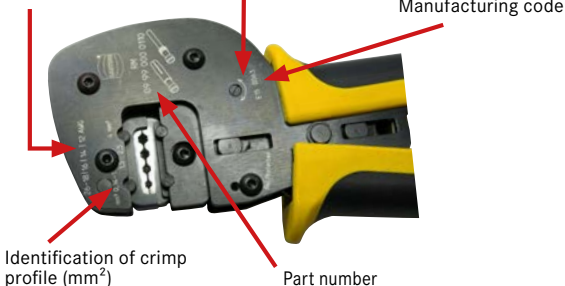
Series	Wire gauge (mm ²)	Wire gauge (AWG)	Stripping length (mm)
Han D [®]	0.14 - 1.5	AWG 26 - 16	8.0
Han E [®]	0.5 - 4.0	AWG 20 - 12	7.5
Han [®] C	1.5 - 4.0	AWG 16 - 12	9.5
Han-Yellock [®]	0.5 - 4.0	AWG 20 - 12	6.5

Identification

Identification of crimp profile (AWG)

Unlocking screw

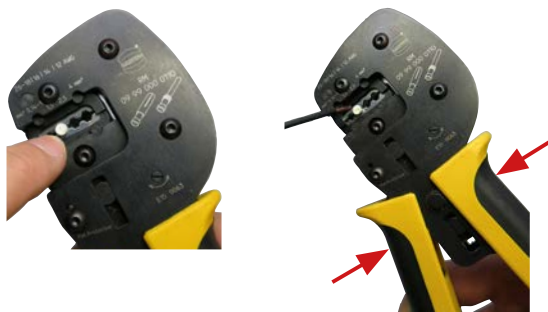
Manufacturing code



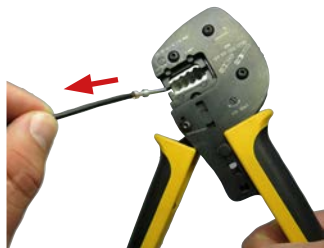
Wire gauges and series

① 0.14 -1 mm ² (AWG 26-18)	Han D [®] , Han E [®] , Han-Yellock [®]
② 1.5 mm ² (AWG 16)	Han D [®] , Han E [®] , Han [®] C, Han-Yellock [®]
③ 2.5 mm ² (AWG 14)	Han E [®] , Han [®] C, Han-Yellock [®]
④ 4.0 mm ² (AWG 12)	Han E [®] , Han [®] C, Han-Yellock [®]

1. Turn the locator to the designated position and insert the crimp contact together with the cable (that has to be stripped exactly according to specifications) into the required crimp profile. Lock the contact by slightly pressing the crimping die.



2. Crimp both components by closing the handles until the controlled accessories cycle mechanism releases.



3. Upon release, the handles will open automatically and the crimped contact can be removed.

Notice:

Check crimp quality visually after every crimp process!

Ratchet mechanism

In order to ensure a consistent crimp quality, the tool is equipped with a releaseable safety catch.

- It prevents the tool from closing before the crimping jaws are fully opened.
- It prevents the tool from opening before the crimp cycle mechanism releases the tool.

Early release

In case of an operating error, it is possible to stop the controlled cycle mechanism and open the tool. Proceed as follows:

1. Relieve the ratchet!
2. Turn the unlocking screw (located above the manufacturing code) left or right until the crimp tool releases the contact.
 - ▶ If the crimp tool is released early, do not use the crimp contacts processed!

Notice:

*Do not use force to open or close the tool;
lubricate all pins, pivot points and bearing surfaces!*

Pull-out forces of crimped connections acc. to DIN IEC 60352-2, A2

Wire gauge		Pull-out force	Han® Contact		
mm ²	AWG	N			
0.14	26	18	D		
0.22	24	28	D		
0.25		32	D		
0.32	22	40	D		
0.50	20	60	D	E	Yellowlock
0.75		85	D	E	Yellowlock
0.82	18	90	D	E	Yellowlock
1.00		108	D	E	Yellowlock
1.30	16	135	D	E	Yellowlock
1.50		150	D	E	Yellowlock C
2.10	14	200		E	Yellowlock C
2.50		230		E	Yellowlock C
3.30	12	275		E	Yellowlock C
4.00		310		E	Yellowlock C

Notice:

If the HARTING Crimp Tool 09 99 000 0110 is used correctly, you will comply with the pull-out forces required by DIN IEC 60352-2, A2

9.3 Operating instructions for service crimping tool 09 99 000 0021

The service crimping tool 09 99 000 0021 can be used with turned HARTING male and female contacts, cross-sectional ranges 0.14 – 2.5 mm² (AWG 26 – 14), the Han D[®], Han E[®] und Han-Yellock[®] series. There are different locators available that can also be ordered separately.

Included in delivery:

- Service crimping tool
- Han D[®] locator (loosely enclosed)
- Han E[®] locator (mounted)
- Operating instructions

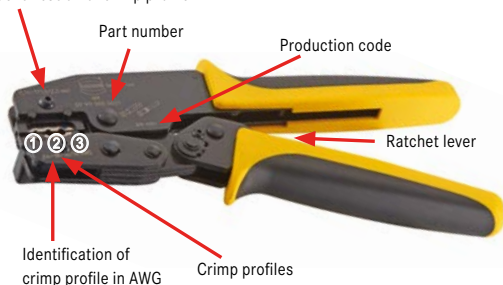
The following table shows which wire gauges can be used with the crimping tool.

Contacts/wire gauges to be processed

Series	Wire gauge		Stripping length
	mm ²	AWG	
Han D [®]	0.14 – 1.5	26 – 16	8 mm
Han E [®]	0.5 – 2.5	20 – 14	7.5 mm
Han-Yellock [®]	0.5 – 2.5	20 – 14	6.5 mm

Structure of the tool

Identification of crimp profile in mm²



Service crimping tool 09 99 000 0021

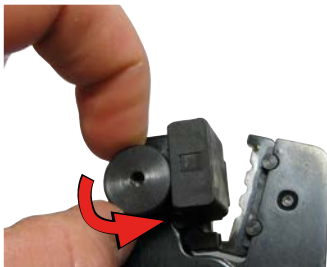
Crimp profiles*

- ① 0.14 – 1 mm² (AWG 26 – 18) Han D[®], Han E[®], Han-Yellock[®]
- ② 1.5 mm² (AWG 16) Han D[®], Han E[®], Han-Yellock[®]
- ③ 2.5 mm² (AWG 14) Han E[®], Han-Yellock[®]

* Numbering according to image caption, Structure of the tool, p. 84.

Locator

The different locators can be used on a contact-specific basis and are labelled for the relevant contact type, this ensures that the crimp contact is processed in the correct position (crimp zone). The exchange is very simple, the thumbscrew located on the lower part must merely be loosened and the respective locator mounted.



Series	Part number
Han D [®]	09 99 000 0022 (Set)
Han E [®]	09 99 000 0022 (Set)
Han-Yellock [®]	09 99 000 0343

V

Opening the knurled screw



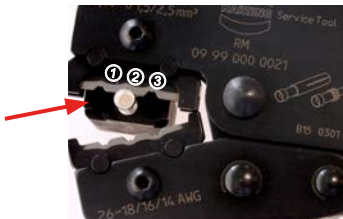
“D” and “E” indicates the appropriate Han[®] series



Back side of locator (Han D[®] 2.5 mm² closed)

Crimping

1. Insert the crimp contact into the crimp profile intended. Use the locator to automatically position the crimp contact in the proper crimping position.



Conductor cross sections and series

0.14–1.0 mm ² (AWG 26–18)	Han D [®] , Han E [®] , Han-Yellock [®]
1.5 mm ² (AWG 16)	Han D [®] , Han E [®] , Han-Yellock [®]
2.5 mm ² (AWG 14)	Han E [®] , Han-Yellock [®]

2. Insert the properly stripped *stranded wire* into the contact and make the crimp by squeezing the tool's handles together until the tool opens again by itself.



3. Remove the crimped contact.



Notice:

You should visually inspect each crimp after it has been completed!

Ratchet mechanism

In order to ensure a constant crimp quality for all contacts, the crimping tool is equipped with a releasable safety catch

- It prevents the crimping tool from closing before the crimping dies are fully opened.
- It prevents the tool from being opened prematurely during the crimping process. This ensures that with each crimping operation the specified compression of the contact is achieved.

Early crimp unclamp

It is possible to effect an early release of the safety device with a screwdriver if the crimp is faulty. The safety device is released by turning right or left.

1. Remove the pressure off the tool by pressing gently on the handle.
2. There is a ratchet lever on the movable handle of the tool. Move it toward the lock unit to swing it out from the rack.
3. Open the tool.

Notice: Do not use force to open or close!

Do not open or close the service crimping tool with force, otherwise you may damage the ratchet mechanism.

Lubricate all moving parts as necessary.

When the service crimping tool is used correctly, the required *pull-out forces* comply with DIN IEC 60352-2 A2.

9.4 Operating instructions for crimping tool 09 99 000 0377

Using the crimping tool 09 99 000 0377, turned HARTING Han® C male and female contacts with *cross-sections* of 6 mm² (AWG 10) and 10 mm² (AWG 8) can be processed. To process these contacts, the crimping tool is pre-fitted with a turnable locator which enables simple and secure handling.



Included in delivery:

- HARTING crimping tool (incl. mounted locator)
- Operating instructions

The following table shows which contacts/wire gauges can be processed with the crimping tool:

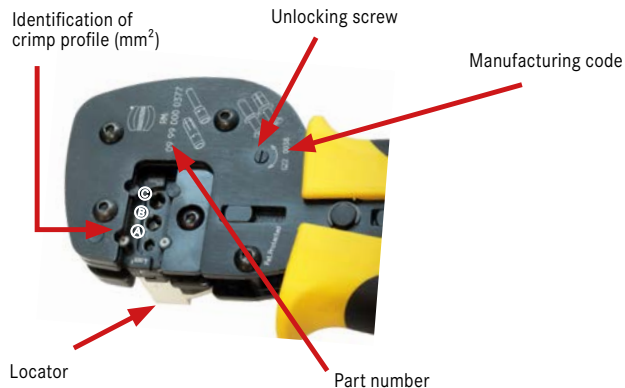
Wire gauges/stripping lengths to be processed:

Series	Conductor cross-section (mm ²)	Conductor cross-section (AWG)	Stripping length (mm)*
Han® C	4.0	12	9.5
Han® C	6.0	10	9.5
Han® C	10.0	8	15.0**

* Cf. table of *stripping lengths*, p.S. 63.
 ** Stripping length = 15.0 mm for cables ≥ 5.0 mm
 Stripping length = 18.0 mm for cables ≥ 6.4 mm

V

Design of the tool



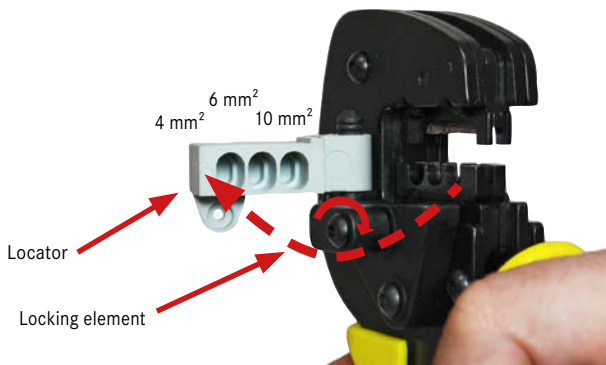
Crimp profiles

- Ⓐ Cable cross-section: 4.0 mm² (AWG 12) ⇒ Han® C
- Ⓑ Cable cross-section: 6.0 mm² (AWG 10) ⇒ Han® C
- Ⓒ Cable cross-section: 10.0 mm² (AWG 8) ⇒ Han® C

Locator

The locator ensures that the crimp contact is always processed in the correct position (crimp zone).

The locator can be removed to process special contacts. To do this, turn the locking element downward and the locator to the left.



Crimping process

1. Insert the crimp contact into the crimp profile intended. The locator automatically positions the crimp contact in the proper crimping position.
2. Press the tool's handles together gently to fix the crimp contact into position.
 - Ⓐ Wire gauge 4.0 mm² (AWG 12) ⇄ Han® C
 - Ⓑ Wire gauge 6.0 mm² (AWG 10) ⇄ Han® C
 - Ⓒ Wire gauge 10.0 mm² (AWG 8) ⇄ Han® C
3. Insert the properly stripped *stranded wire* into the contact and make the crimp by squeezing the tool's handles together until the tool opens again by itself.
4. Remove the crimped contact

Notice: Check the quality of the crimp!

You should visually inspect each crimp after it has been completed.

Ratchet mechanism

In order to ensure a constant crimp quality for all contacts the crimping tool is equipped with a releasable safety catch.

- The hand crimping tool can only be used after it has been opened completely.
- This prevents the tool from being opened prematurely once the crimping process has been started.

Early release

In the event of an operational error, it is possible to release the crimping tool before it has completed the crimp.

The following procedure must be observed here:

1. Remove the pressure off the lock unit by pressing gently on the handle.
2. Move the release screw (located above the production codes) to left or right, until the tool releases the contact. This prevents damage in cases where the crimp contact is inserted incorrectly in the crimp profile.

CAUTION!

Do not use force to open and shut the crimping tool.

Lubricate all moving parts when needed.

Pull-out forces of crimp connections according to DIN IEC 60352-2, A2

Cross-section		Pull-out force	Han® contacts
mm ²	AWG	N	
4.0	12	310	
6.0	10	360	C
10.0	8	380	C

When the HARTING crimping tool is used correctly, the required *pull-out forces* comply with DIN IEC 60352-2 A2.

9.5 Battery crimping tool 09 99 000 0990



Overview: HARTING Battery crimping tool 09 99 000 0990

HARTING Battery crimping tool – included in delivery

Part no.	Identification
09 99 000 0990	Battery crimping tool (Set)
09 99 000 0832	Crimping tool incl. crimping die
	Battery charger
09 99 000 0991	Locator Han D®
09 99 000 0992	Locator Han E®
09 99 000 0993	Locator Han® C

Technical details

Characteristic	Value	Specification	Value
Weight (incl. battery):	0.96 kg	Battery capacity:	1.5 Ah, Li-Ion
Pressing force:	15 kN (maximum)	Charging time:	40 minutes
Ambient temperatures:	-10°C ... +40°C	Battery voltage:	10.8 V
Processing time per crimping:	< 1.5 s (depending on contact diameter)		
Number of crimpings per battery:	~300 pressings (using 4 mm ² contacts per battery charge)		
Sound pressure level:	< 70 dB (A) at a distance of 1 m		
Vibrations:	< 2.5 m/s ² (weighted RMS of acceleration)		

Suitable contacts and accessories

Contacts to be processed (series)	Diameter
- Han D®:	0.14 ... 1.5 mm ²
- Han E®:	0.5 ... 4 mm ²
- Han® C:	1.5 ... 4 mm ² / 4 ... 10 mm ²
Accessories	Part no.
- Locator Han D® (0.14 ... 1.5 mm ²)	09 99 000 0991
- Locator Han E® (0.5 ... 4 mm ²)	09 99 000 0992
- Locator Han® C (1.5 ... 4 mm ²)	09 99 000 0993
- Set: Crimping dies for Han® C (4 ... 10 mm ²) + Locator Han® C (4 ... 10 mm ²) (not included in delivery)	09 99 000 0995

Insertion of the crimping die

As a standard, the battery crimping tool 09 99 000 0990 is equipped with a die for processing crimped contacts of the Han D[®], E[®] and Han[®] C series. The contacts may have a maximum diameter of 4 mm. To process larger contacts, a Han[®] C crimping die for conductors with cross-sections of 4, 6 or 10 mm² is available.

The installation of the crimp die is described using the example of the standard crimp die for this tool. From the rear, depending on the type of contact, a special positioner must be inserted to ensure a uniform processing quality for the various crimp contacts (⇒ Crimping subchapter, p. 94).

V

Assembly steps

Warning: Risk of crushings!

The ready-to-use battery crimping tool can be released accidentally.

- ▶ Always disconnect the battery before you insert or remove the crimp die!

1. Loosen the fixing screws (A) and (B) from the tool head.

2. Insert the die (C+D) that is suitable for your type of contact in the specified positions of the tool (⇒ red arrows).

- ▶ Check if the crimping die is correctly seated while the release lever is in the correct position.



Notice:

The crimping die is correctly aligned if the inscriptions are legible and not upside down(⇒ C+D).

③



3. Pull up the release lever until the crimp die closes firmly and both parts of the crimping die hold position.

④



4. Keep the tool closed so that the upper and lower crimp die remain fixed in the correct position until you tighten the screws.

Ⓑ

⑤



5. Use a 2.5 mm Allen key to tighten both fixing screws (⇒ red arrows). The recommended torque is 2.0 Nm.

Notice:

Make sure to use the correct fastening screws to position the locator. Insert the longer screw Ⓑ in the lower die, and the shorter one Ⓐ in the upper die.

⑥



6. Open the crimping tool again.

⑦



7. Insert the locator in the designated position and fix it with the supplied screw (⇒ red arrow).

► Reinsert the battery.

V

Crimping

Before starting to crimp:

Check whether you have selected the correct locator for processing the selected contact type. The locator automatically selects the required recesses for crimping your contact type.

Locator and contact dimensions

Position	Contact type	Diameter
①	Han D®	0.14 ... 1.5 mm ²
②	Han E®	0.5 ... 4 mm ²
③	Han® C	1.5 ... 4 mm ²
④	Han® C	4 ... 10 mm ²

- Remove the battery and attach the positioner suitable for your contact type!

Notice



Positions of release lever

The lever for triggering the crimping process can take three different positions:

Stage III (upper position): Crimping die closed, crimping process starts.

Stage II (mid position): Crimping die mechanically closed, contacts can be fixed between die halves. No deformation!

Stage I (lower position): Crimping die opened, contacts can be inserted.

Crimping process

1. Insert the contact into the appropriate positioner / the appropriate position in the crimp die.
2. Fix the contact between the upper and lower die.

Lever:
Stage I

①



Lever:
Stage I

②



Lever:
Stage I



3. Lower the release lever so that the die opens and the contact can be re-adjusted if necessary.

Lever:
Stage II



4. Fix the positioned contact and insert the stripped wire.

Lever:
Stage I

⑤



5. Crimping

Lever:
Stage I

⑥



6. Open the crimping die again!

Lever:
Stage I

⑦



7. Remove the cable end with the crimped contact and carry out a visual inspection.

Notice:

Remove contact only when the crimping die is completely open!

9.6 Crimping tool for D-Sub reel-packaged contacts 09 99 000 0169

1. Application field

The crimping tool is designed for crimping of D-Sub connectors. These are supplied in carrier strips of approx. 500 contacts per roll. The roll holder, indexing unit and two crimp profiles ensure easy handling with the best crimp result.

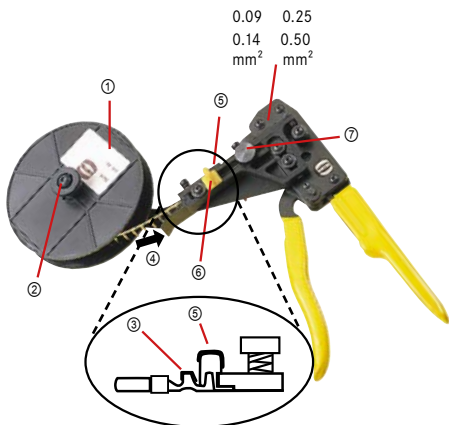
- Crimp profile 0.08 – 0.20 mm²
- Crimp profile 0.20 – 0.56 mm²

Each crimp profile crimps the contacts onto the conductors of the wire and the insulation in one step. After the crimping process, the contact is automatically cut from the carrier strip. The wire is then easily removed from the tool with a successful crimp installed onto the wire.

2. Indexing unit

The contact strip with the indexing unit moves into the correct position and is terminated as follows:

1. Assemble the contact roll ① on the roll holder ② holding it in place with the knurled nut ③. The contacts point towards the roll holder!
2. Close the tool until the ratchet lock releases.
3. Insert the contact strips ④ in the direction of the arrow, between the indexing unit and the retaining plate so that the indexing unit is guided fully to the end of the retaining plate between the wire crimp and insulation crimp.
4. Index the contact strip forward ⑤.



3. Adjustment of Indexing Unit

You must adjust the indexing unit before you process contacts in the 1st or 2nd crimping profile.

1. Undo the knurled nut.
2. Move the Indexing Unit to the left or to the right.
3. Tighten up the knurled nut again!
4. Check to see if the contact is in the middle of the respective crimp profile.

4. Crimping

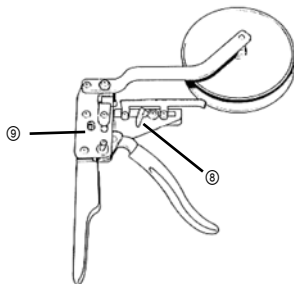
1. Ensure that the contact is in the middle of the crimp profile after the indexing.
2. Close the tool to the first detent.
3. Slide the wire into the contact.
4. Close the manual crimper completely until the safety ratchet allows the tool to be opened.
5. Remove the crimped contact.

Notice: Remove the empty carrier strip!

Regularly break off the empty carrier strip behind the bending plate ⑦, so that the carrier strip does not interfere with handling of the tool.

5. Change the contacts

1. Release the red release lever ⑧ on the indexing unit in direction "Release" and hold it there.
2. Pull-out the contact roll away from the indexing unit towards the roll ⑩.
3. Remove the contact roll.
4. Load the indexing unit as stated in paragraph 3.



6. Safety ratchet

The hand crimping tool can only be used after it has been opened completely. Each crimp process has to be done fully, before the tool can be opened again. This guarantees a good quality crimp each time.

7. Early Release

It is possible to release the tool early:

1. Push the tool handles slightly together.
2. Release the safety lock ⑨ on the rear of the tool by turning it anticlockwise.
3. Open the tool handles.

8. Maintenance

Remove any existing material and dirt and clean the crimp zone regularly. Check the tool to ensure that the profile closes correctly, clean moving parts and oil them lightly (machine oil SAE 20). It is only permitted to have damage repaired by authorised personnel!

9.7 HARTING crimping tool 09 99 000 0620 for stamped contacts BC and FC according to DIN 41612

Notice:

Only use the crimping tool for crimping!

Only use HARTING crimp inserts!

Protect the crimping tool from dust and moisture!



The base tool 09 99 000 0620 can be provided with the following crimp insert sets:



Crimping die set no.	For individual contacts		Cross-section range mm ²	Insulation Ø mm
09 99 000 0621	0902 000	BC	0.09 – 0.50	0.7 – 1.5
09 99 000 0621	0906 000 ...4	FC 1	0.09 – 0.25	0.7 – 1.5
09 99 000 0622	0906 000 ...1	FC 2	0.14 – 0.56	0.8 – 2.0
09 99 000 0623	0906 000 ...2	FC 3	0.50 – 1.50	1.6 – 2.8

FC contacts have an identification marking on the back.

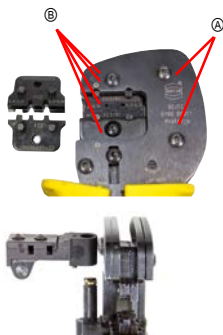


The locators are part of the respective sets, but can be ordered separately:

09 99 000 0630	locator BC	included in	09 99 000 0621	Crimp set BC/FC1
09 99 000 0631	locator FC1		09 99 000 0621	Crimp set BC/FC1

Inserting the crimp sets

1	Unscrew the fixing screw Ⓐ with crimping tool closed.
2	Then release and open the crimping tool.
3	Remove inserts, the upper insert first.
4	Insert the new inserts – the colour marking must match the markings Ⓑ on the tool (the lower insert first).
5	Secure the inserts with the fixing screws: ISKA M4x18 (upper); ISKA M4x9 (lower)
6	Plug the locator from the top so that the contact holder points in the direction of the tool when in a closed state.



Locking mechanism

In order to ensure a constant crimp quality for all contacts, the crimping tool is equipped with a releasable safety catch.

- The hand crimping tool can only be used after the opening process is completed.
- This prevents the tool being opened prematurely once the crimping process has started.



Early crimp release

The crimping tool is unlocked by

1. slightly pressing the tool together,
 2. turning the screw (refer to red arrow), both directions possible.
- Now the crimping tool can be completely opened.

Notice:

Do not use force to open or close the crimping tool.



Crimping

1. Fold out the locator.
2. Insert the individual contact into the locator [Ⓐ]. Make sure you use the right chamber!
3. Fold in the locator.
4. Close the tool up until the contact is securely held [Ⓑ].
5. Insert the wire into the contact.
6. Crimp the contact until the tool releases.
7. Remove the crimped contact.



Maintenance

- Clean the crimping tool of dust and oil!
- Protect the crimping tool from dust and moisture!

Table: Pull-out forces of crimped contacts is in accordance with IEC 60352, Part 2

Cross-section	Breaking force of the stranded wire
0.09 – 0.25 mm ²	75 %
0.38 – 0.57 mm ²	65 %
0.75 – 1.50 mm ²	60 %

Notice:

We reserve the right to modify designs in order to improve quality, keep pace with technological advancement or meet particular requirements in production.

9.8 HARTING service crimping tool 09 99 000 0191 for FC individual contacts

Service crimping tool Gds A-F/FC

0.14 – 1.5 mm²

AWG 26 – AWG 16



Ratchet mechanism

In order to ensure a constant crimp quality for all contacts, the crimping tool is equipped with a releasable safety catch.

- The hand crimping tool can only be used after it has been opened completely.
- This prevents the tool being opened prematurely once the crimping process has started.

Early release

It is possible to perform an early release of the safety ratchet in case of a faulty crimping. Proceed as follows:

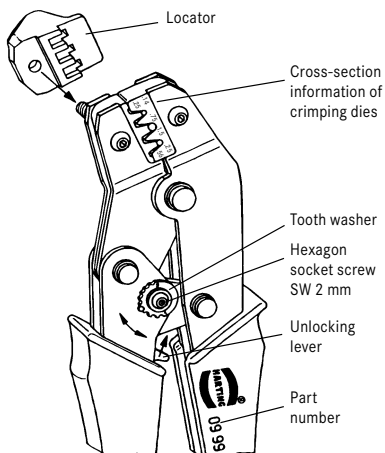
1. Remove the pressure off the crimping tool by pressing gently on the handle.
2. Operate the release lever in the direction of the tool head (refer to sketch).
3. The crimping die is now protected in the event that the contact does not lie correctly in the crimp profile.

Notice:

Do not open or close the tool by force, oil moving parts every week!

Fixing the locator

The supplied locator must be fastened on the upper part of the tool head (refer to sketch).



Crimping process

1. Insert the contact into the locator.
2. Hold the contact between the slightly closed crimping dies.

3. Insert the stripped *stranded wire* into the contact.
4. Crimp until the tool opens again.
5. Remove the crimped contact.

Adjustment of the crimping depth

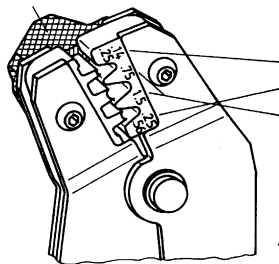
If after prolonged use the crimp tensile strength in the connection between the *stranded wire* and the barrel of the contact is no longer sufficient, the pressure of the dies can be increased by adjusting the eccentric ratchet plate.

1. Loosen by two turns of the hexagonal socket screw with a hexagon screwdriver (SW 2 mm).
2. Lift the toothed spring washer and turn it by hand counter clockwise in direction "9". Tighten the hexagonal socket screw.

Pull-out force of the crimped wire in the connection is in accordance with DIN 41611, Part 3, and IEC 60352-2

Cross-section		Breaking force of the stranded wire
mm ²	AWG	
≤ 0.3	≤ 24	75 %
> 0.3 - 0.6	> 24 - 20	65 %
> 0.6 - 1.5	> 20 - 16	60 %

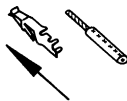
Locator



Cross-section	
mm ²	AWG
0.14-0.25	26-24
0.25-0.56	24-20
0.75-1.5	18-16

Notice:

We reserve the right to modify designs. To improve quality, we keep pace with technological advancement or meet particular requirements in production.



9.9 Crimping tools for single contacts FC/BC and *har-bus*



Field of application

The crimping tools 09 99 000 0770 to 09 99 000 0773 were developed for processing single crimp contacts. The crimping profiles offered combine good handling features with best crimping results.

Type of contact, crimp profile and suitable crimping tool

Type of contact	Contact part no.	Crimp profile	Crimping tool part no.
Single contacts BC/ <i>har-bus</i> 64	02 05 000 2513 02 05 000 1513 09 02 000 8484 09 02 000 8474	0.09 – 0.20 mm ²	09 99 000 0770
		0.20 – 0.50 mm ²	
Single contacts FC 1	09 06 000 8484 09 06 000 8474	0.09 – 0.20 mm ²	09 99 000 0771
		0.20 – 0.50 mm ²	
Single contacts FC 2	09 06 000 8481 09 06 000 8471	0.14 – 0.32 mm ²	09 99 000 0772
		0.32 – 0.56 mm ²	
Single contacts FC 3	09 06 000 8482 09 06 000 8472	0.05 – 1.30 mm ²	09 99 000 0773
		1.00 – 1.50 mm ²	

Each profile crimps the conductor and the insulation crimp area of the contact in one operation.

Early release mechanism

The hand tool can only be operated after it has been completely closed. Every crimping process must be carried out completely before the tool can be opened again. This ensures a consistently good crimp quality.

However, an early release of the tool is possible.

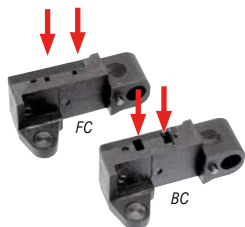
The process works as follows:

1. Slightly press the tool's handles together.
2. Release the forced lock (⇒ red arrow) at the back of the tool by turning it to the left.
3. The tool's handles can be opened.



Crimping

1. Open the positioner.
2. Insert the single contact into the positioner – take care to use the correct chamber for this (⇒ red arrows)!
3. Fold back the positioner.
4. Now close the tool until the contact is held securely (⇒ red arrow).
5. Insert the wire into the contact.
6. Carry out the crimping until the pliers are released.
7. Remove the crimped contact



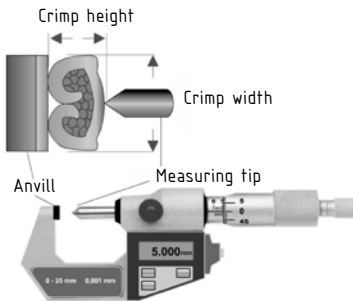
V



Quality features

The quality of a crimp is evaluated by the crimp height and the pull-out forces achieved.

The specifications for measuring the crimp dimensions can be found in the tables on page 104. There you will also find information on permissible pull-out forces and crimp heights.



Tool 09 99 000 0770

Conductor cross-section		Pull-out force
mm ²	AWG	
0.14	26	≥ 18 N
0.25	24	≥ 32 N
0.50	20	≥ 60 N
0.75	18	≥ 85 N
1.50	16	≥ 150 N

Stripping length of stranded wire:
3.5 mm^{+0,5mm}

Tool 09 99 000 0771

Conductor cross-section mm ²	Crimp height	Pull-out force
0.15	0.82 mm ^{±0,05mm}	≥ 15 N
0.25	0.86 mm ^{±0,05mm}	≥ 28 N

Stripping length of stranded wire: 3.5 mm^{+0,5mm}

Tool 09 99 000 0772

Conductor cross-section mm ²	Crimp height	Pull-out force
0.25	1.04 mm ^{±0.05mm}	≥ 28 N
0.50	1.02 mm ^{±0.05mm}	≥ 40 N

Stripping length of stranded wire: 3.5 mm^{+0,5mm}

Tool 09 99 000 0773

Conductor cross-section mm ²	Crimp height	Pull-out force
0.75	1.34 mm ^{±0.05mm}	≥ 85 N
1.50	1.02 mm ^{±0.05mm}	≥ 150 N

Stripping length of stranded wire: 3,5 mm^{+0,5mm}

Service and maintenance

Remove possibly existing material and dirt residues, clean the crimp zone. Check the tool for the correct closing of the profiles, clean moving parts and lightly oil.

- Clean after every 50 crimpings
- Crimp check after every 1,100 crimpings
- Maintenance after 5,000 crimpings / 3 years

Notice:

- Use tool only for crimping!
- With this tool, only HARTING crimp contacts can be processed.
- Protect the tool from dust and moisture!
- If a damage is detected, repairs must be carried out by qualified personnel!

9.10 Service Crimping Tool FC1/FC2/FC3 (09 99 000 0656)

Information

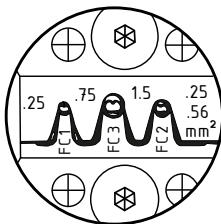
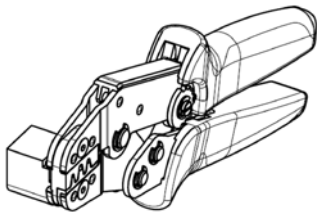
The tool has a safety lock, which only releases the crimping tool after a complete crimp.

Locator

The locator is assembled on delivery but can be loosened with an Allen key and replaced if necessary.

Crimping

1. Open the pliers completely and insert the contact into the opening provided in the locator (refer to cross-section information).



Sequence of crimp openings, from left to right: FC1, FC3, FC2

2. Now close the pliers up to the first or second click.
3. Then insert the stripped wire into the contact and then crimp the contact by pressing the handles together quickly and evenly.
4. The crimp is ready when the handles are released and open again. Remove the contact on the wire.

Service & maintenance

The tool is almost maintenance-free. Make sure that the crimp opening is free of residues and dirt.

- Clean after every 50 crimpings
- Crimp check after every 1,100 crimpings
- Maintenance after 5,000 crimpings / 3 years

interlock

In order to ensure a constant crimp quality, the pliers are equipped with a lock.

- It does not allow the pliers to close until the crimp jaws are not fully open.

- It prevents the tool from opening prematurely, when the crimping process has started.

Early Release

It is possible to unlock the lock prematurely in the event of incorrect crimping. The pliers must be relieved by lightly pressing them together. Operate the release lever in the direction of the pliers head. This prevents damage to the crimping dies if the contact is not correctly in the crimping profile.

Caution!

Make sure that...

- *the tool is not immersed in cleaning baths*
- *the tool is not disassembled*
- *moving parts are oiled weekly*

Holding force of the crimped wire in the connector according to IEC 60352, part 2.

Conductor cross-section		Pull-out force
mm ²	AWG	
0.14	26	≥ 18 N
0.25	24	≥ 32 N
0.50	20	≥ 60 N
0.75	18	≥ 85 N
1.50	16	≥ 150 N

Notice:

Only use tools for crimping!

Only HARTING crimp contacts can be processed with the tool!

Protect the tool from dust and moisture!

Do not open the tool by force!

10. Assembly and disassembly instructions

10.1 Assembly of contacts

After crimping the *stranded wire* to the contact with a manual tool or a crimping machine, the contacts are then inserted and locked into the contact chambers with the tool from the termination side. A mounting tool is required with *stranded wires* under 0.5 mm² (refer to Table V-18 and Table V-19).

		
<i>Insert contact with crimped wire into the contact chamber on the termination side.</i>	<i>Insert plug contact until it stops, until the contact clicks audibly.</i>	<i>Check that the catch is firmly seated by lightly pulling on the stranded wires.</i>

V

Table V-18: Assembly tools for turned contacts of industrial connectors

Type	Part number
D-Sub	09 99 000 0171
Han D®	09 99 000 0059
Han E®	09 99 000 0059
Han® C	n/a




Table V-19: Assembly tools for stamped contacts of industrial connectors

Type	Part number
FC1	09 99 000 0088
FC2	09 99 000 0088
FC3	09 99 000 0088
BC	09 99 000 0100
har-bus® 64	n/a

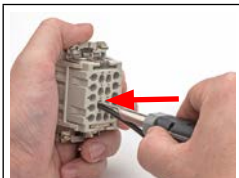


10.2 Removal of contacts

If you want to remove a crimp contact, you need a tool that is matched to the type of contact (refer to Table V-20 and Table V-21, p. 109). Using the appropriate tools, HARTING contacts can be gently and safely removed from the contact chamber. It is strongly discouraged to disassemble with a tool that is not specially intended for the purpose, e.g. a screwdriver. Using an unsuitable tool, the danger of damaging the contact and contact chamber is higher.

Han D® contacts

		
<p><i>Insert the tool from the mating side via the contact to the stop.</i></p>	<p><i>Press the removal tool into the contact chamber, and the retaining spring is also released on contact.</i></p>	<p><i>Pull out the contact at the crimped wire to the back.</i></p>

Han E® contacts

		
<p><i>Insert the tool from the termination side next to the stranded wire over the recess intended for this (⇒ red arrow) into the contact chamber.</i></p>	<p><i>Press the tool in to the stop. This opens the contact chamber.</i></p>	<p><i>Pull the contact at the crimped stranded wire together with the tool out of the contact chamber.</i></p>

Han® C contacts

The removal of the Han® C contacts is the same as the removal of the Han E® contacts.

Table V-20: Removal tools for turned contacts for industrial connectors

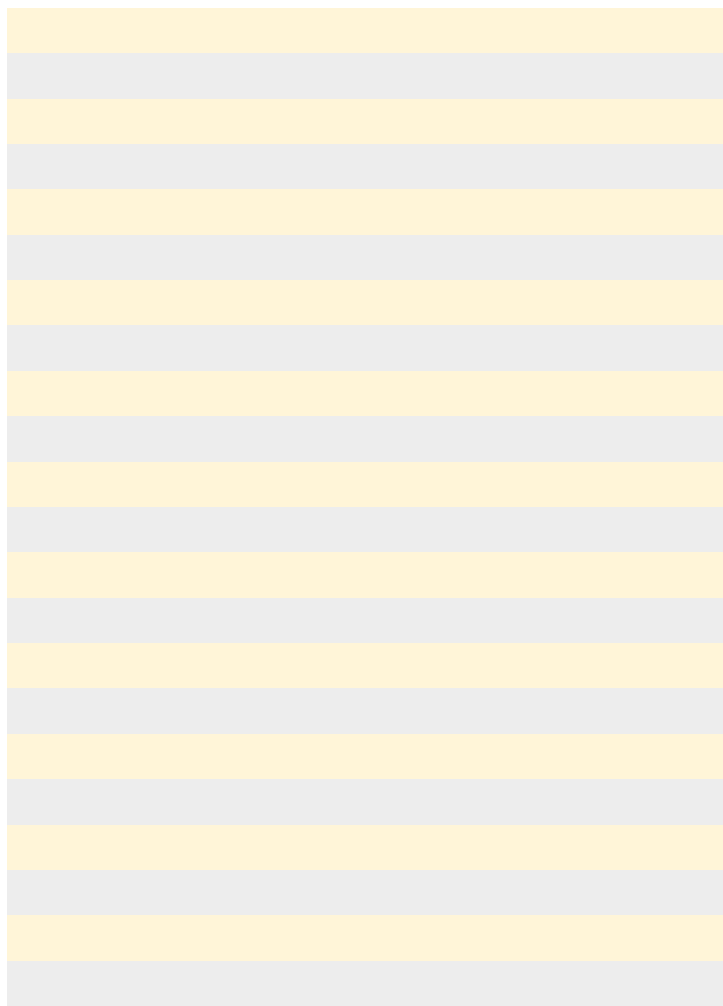
Type	Part number
D-Sub	09 99 000 0171
Han D®	09 99 000 0012
Han E®	09 99 000 0319
Han® C	09 99 000 0305/0381

Table V-21: Removal tools for stamped contacts for electronic connectors

Type	Part number
FC1	09 99 000 0087
FC2	09 99 000 0087
FC3	09 99 000 0087
BC	09 99 000 0101
har-bus® 64	02 99 000 0013

Notes

V



VI. Cage-clamp termination

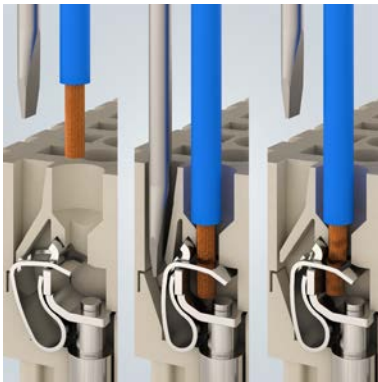
Table of contents

1. Introduction	112
2. Features.....	113
2.1 Cage-clamp termination technology: general information.....	113
2.2 Cage-clamp combined with press termination technique (Han® ES Press).....	113
3. Cage-clamp terminals in HARTING products.....	114
4. Assembling the cable-clamp terminals.....	115
4.1 Standard cage-clamp contacts	115
4.2 Han® ES Press	117
4.3 Using ferrules.....	119
4.4 Possible assembly errors	119
5. Standards and guidelines.....	120

1. Introduction

In cage-clamp termination technology, a spring terminal secures the end of the wire in the insert. This cage-clamp establishes an electrically conductive connection with the contact. HARTING offers two types of cage-clamp contacts. The first variant comes delivered with the cage-clamp closed. A screwdriver or HARTING assembly tool is used to open the terminal so that the wire can be inserted. The second variant, Han[®] ES Press, is delivered with the actuator already open.

Ⓐ



Ⓑ

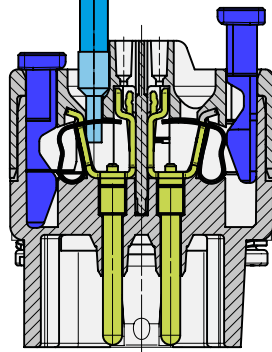


Fig. VI-1: Termination principles of standard cage-clamp Ⓐ and Han[®] ES Press Ⓑ

2. Features

2.1 Cage-clamp termination technology: general information

- Connects wires (with or without ferrules) with cross-sections from 0.14 mm^2 to 2.5 mm^2
- High current carrying capacity
- Consistently low potential drop at the termination point.
- Spring exerts constant pressure on the wire so no maintenance is required
- Clamping force increases as the wire diameter increases
- Saves time compared to the screw terminal technique
- Easy to handle and less tool work
- Reduced material and labour costs, since assembly possible without ferrules or pin-end connectors, and no special processing of the wire end is needed.
- Connection is resistant to shock and vibration, in compliance with DIN EN 50467
- Can be tested directly at the termination point (when using the Han® ESS)

VI

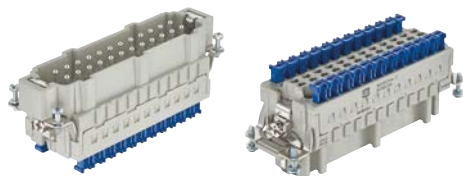
2.2 Cage-clamp combined with press termination technique (Han® ES Press)

- Rapid termination technique based on cage-clamp technology requires no tools
- Easy to handle with quicker processing times than other termination techniques
- Very convenient to work with:
 - It is quick and simple to connect the wire directly, since the terminal actuators are delivered open
 - No force is needed to insert the wire into the contact chamber
 - Actuator snaps in with an audible and tactile click
 - The actuator can be quickly and easily opened using a conventional screwdriver when you need to remove the wire
- Connects wire (with or without ferrules) with cross-sections from 0.14 mm^2 to 2.5 mm^2
- Plug-in bridges can optionally be used to bridge contacts and distribute potentials (e.g. when connecting motors, sensors etc.)

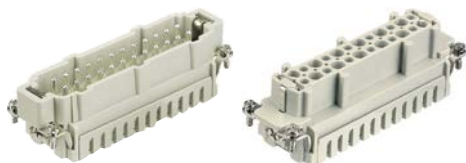
3. Cage-clamp terminals in HARTING products

The cage-clamp contacts are being used in inserts for the following HARTING product series: Han[®] ES Press, Han[®] ES, Han[®] ESS, Han[®] HvES, Han-Modular[®], Han[®] ES AV, DIN rails in size H, Industrial Ethernet products as well as in other customised solutions.

Figure VI-2: Han[®] products with cage-clamp contacts



- Han[®] ES Press: quick, tool-free connection



- Han[®] ES: no special tools are required



- Han[®] ESS: two connections per contact



- Han[®] ES Module; cage-clamp termination
Han-Modular[®]

- Han[®] ES AV: quick connections with
angled shape

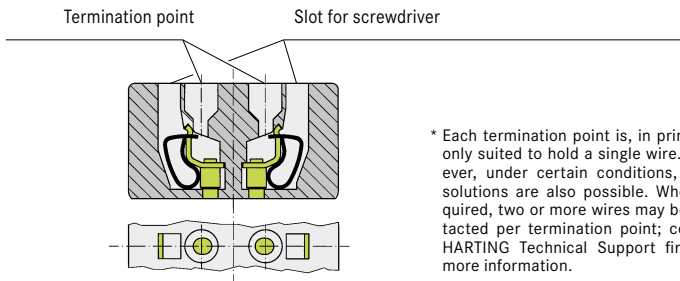
4. Assembling the cable-clamp terminals

4.1 Standard cage-clamp contacts

Before starting the assembly, note the markings for the wire inlets and for the screwdriver on the inserts. The rectangular slot is used to hold the assembly tool that opens the termination point. Use the HARTING assembly tool listed in Table VI-1 or a screwdriver in accordance with Table VI-2, p. 116. The round opening is used to hold the wire that is being connected.

Notice:


*Only one wire per termination point is permitted!**



* Each termination point is, in principle, only suited to hold a single wire. However, under certain conditions, other solutions are also possible. When required, two or more wires may be contacted per termination point; contact HARTING Technical Support first for more information.

Figure VI-3: Structure of termination point with cage-clamp

Table VI-1: Assembly tools for use with the Han® ES / ESS and ES Module series

Assembly tool	09 99 000 0367	
---------------	----------------	---

Notice:

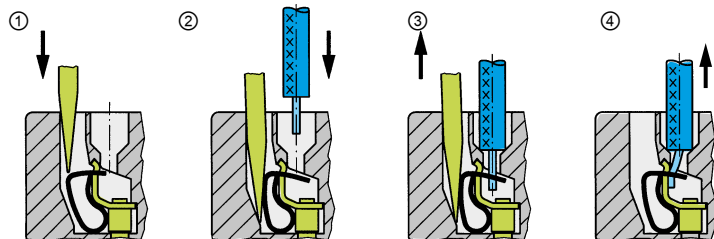
An effective and durable spring clamp connection requires that the wire is properly stripped. The correct stripping lengths for Han® ES, Han® ESS and DIN 41612 contacts are specified in Table VI-1.

Table VI-2: Stripping lengths and cross-sections

Insert	Max. cross-section		Stripping length (mm)	Recommended screwdriver width (mm)
	mm ²	AWG		
Han [®] ES, Han [®] HvES, Han [®] ES AV, Han [®] ES Module	0.14 – 2.5	26 – 14	7 – 9	3.5 x 0.5
Han [®] ESS	0.14 – 2.5	26 – 14	9 – 11	3.5 x 0.5
DIN 41 612 size H 15	0.14 – 1.5	26 – 16	4 – 7	2.5 x 0.4

If required, the stripped stranded wire can also be fitted with a ferrule (refer to Chapter VI-4.3, Using ferrules, p. 119).

Assembly



① ② ③ Screwdriver width: 3.5 x 0.5 mm

④ = Gentle test pull!

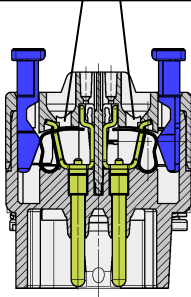
- ① Strip the wire in accordance with DIN EN 60352, part 7. Refer to Table VI-2 for *stripping lengths*. Insert the screwdriver or assembly tool in the appropriate slot in order to open the contact chamber.
- ② Insert the stripped wire into the appropriate slot.
- ③ Remove the screwdriver/assembly tool from the slot.
- ④ Pull gently to make sure the connection is secure.

4.2 Han® ES Press

The circular openings in the insert are used to hold the wire that is being connected. Note that there are two rows of rectangular holes (intended for plug-in jumpers) located between the contact openings of the Han® ES Press insert.

Notice:

*Only one wire per termination point!**



* Each termination point is, in principle, only suited to hold a single wire. However, under certain conditions, other solutions are also possible. When required, two or more wires may be contacted per termination point; contact HARTING Technical Support first for more information.

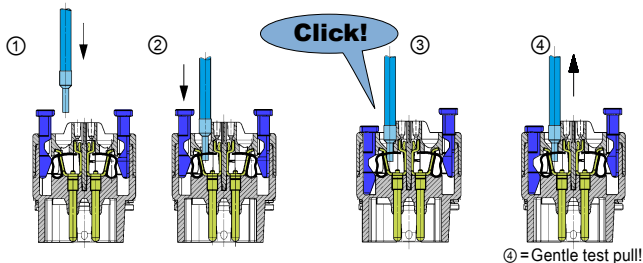
VI

Figure VI-4: Structure and arrangement of termination points with Han® ES Press

Notice:

An effective and durable spring clamp connection requires that the wire is properly stripped. The correct stripping lengths for the Han® ES Press contacts are specified in Table VI-3, p. 118.

Assembly



- ① Insert the stripped wire (according to Table VI-3) into the Han® ES Press contact chamber. Do not use force.
- ② Press the actuator with your hand or using a screwdriver in the contact chamber.
- ③ The actuator will snap in with an audible click.
- ④ Pull gently to check if the wire is securely attached.
- ⑤ Before processing further, make sure that all actuators are closed.

Table VI-3: Stripping lengths and wire cross-sections for Han® ES Press

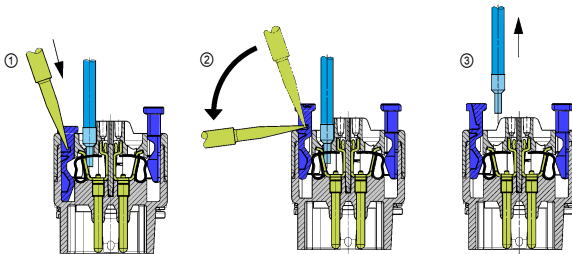
Insert	Maximum cross-section		Stripping length (mm)	Recommended screwdriver width (mm)
	mm ²	AWG		
Han® ES Press	0.14 – 2.5	26 – 14	9 – 11	2.5 x 0.5

VI If required, the stripped wire can also be fitted with a ferrule.

Removal

Notice:

To remove the wire, use a conventional screwdriver with a blade of 0.5x2.5 mm.



- ① Insert the screwdriver gently and at an angle onto the actuator.
- ② Use the screwdriver as a lever to gently press down.
- ③ Remove the wire from the contact chamber when the actuator is in its upper position (the cage-clamp is opened).

4.3 Using ferrules

Figures VI-4 and VI-5 show the cage-clamp connections. The *micro-sections* show that this termination method delivers equally high quality connections both for prepared wires (with ferrules already crimped on) and for unprepared (only stripped) wires.

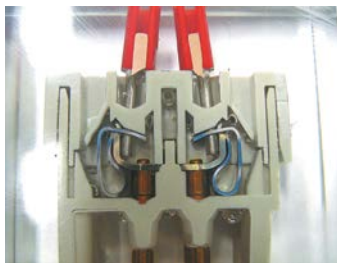


Figure VI-4: Termination with ferrule crimped on



Figure VI-5: Termination with stripped stranded wire

VI

4.4 Possible assembly errors

Notice:

Errors may occur if you do not follow the assembly instructions accompanying the inserts and cage-clamp termination modules!

The connection between the wire and the contact must be very carefully established so that the resulting cage-clamp and connector function properly and are standard-compliant. In this respect, the cage-clamp is no different than other wire termination types. The following preventable errors may occur when making a cage-clamp termination:

- The stranded wire is improperly inserted into the contact chamber, or the wire is inserted into the wrong slot.
- The stripping tool has not been set properly.
- The stripping tool blade is damaged.
- The wrong assembly or removal tool is being used.
- The wire has the wrong cross-section: $\varnothing < 0.14 \text{ mm}^2$ or $\varnothing > 2.5 \text{ mm}^2$.

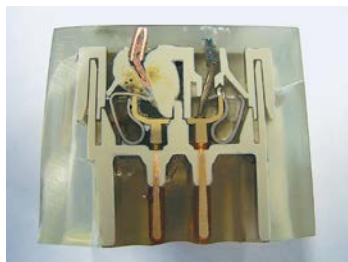


Figure VI-6: The consequences of improper assembly (shown here on the Han® ES)



Figure VI-7: The consequences of improper assembly (shown here on the Han® ES), close-up

VI In the example shown by Figures VI-6 and VI-7, the contact chamber was opened using an improper tool and the spring terminal was damaged. The connector burned as a result.

5. Standards and guidelines

The requirements for making and testing cage-clamp contacts are specified in the DIN EN 60 999 and DIN EN 60352-7 standards. A key factor is the *tensile strength*: some of the required values are shown in Table VI-4.

Table VI-4: Minimum tensile strength

Tensile strength of connections (DIN EN 60352-7, Table 1)							
Wire cross-section, mm ²	0.22	0.34	0.5	0.75	1.0	1.5	2.5
Min. tensile strength, in N*	10	15	20	30	35	40	50

* 10 N correspond to a force of approx. 1 kg.

VII. Han® Push-In technology

Table of contents

1. Rapid termination technique.....	122
2. Termination details.....	122
3. Assembly	124
3.1 Assembly with stranded wires	124
3.2 Assembly with wire ferrules (insulated/uninsulated)	125
3.3 Assembly with solid wires.....	125

1. Rapid termination technique

Push-In termination technology is a further evolution of the cage clamp. It is particularly well suited for on-site installations due to its speed and simplicity. An actuator can be used to hold the clamping spring open while the wire strand is being inserted into the contact chamber. When the strands are fitted with a wire ferrule, the mere insertion force is sufficient to open the clamping spring. With stripped stranded wires, however, the spring should be kept open using the actuator until the wires reach the end of the contact chamber. When the screwdriver is withdrawn, the spring will rest against the contact point.

2. Termination details

Figure VII-1 shows the core of the Han® Push-In connection. The termination is very safe thanks to the force of the clamping spring: it lays against the wire strand and ensures a permanent contact for the connection. The high wire pull-out forces are also based on the force of this clamping spring.

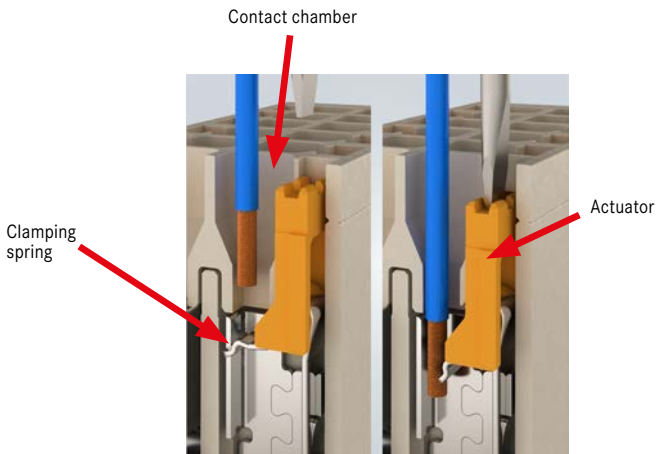


Figure VII-1: Contact chamber Han® Push-In module with termination

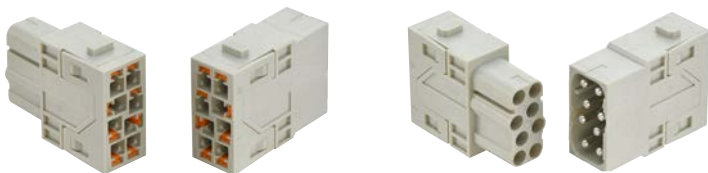


Figure VII-2: Termination and mating side of the Push-In module EE

Conductor cross-section

The usable conductor cross-sections for the Han[®] Push-In modules range from 0.14 mm² to 6 mm². These connections enable the transmission of signals and power up to 40 A. The force of the Push-In spring presses continually on the inserted wire, ensuring a connection that is both durable and robust. As the cross-section of the conductor increases, the effective spring force increases as well. Thus, the conductor pull-out forces meet the requirements of IEC 60352-7.

VII

Compatibility

The Han[®] Push-In inserts are compatible with similarly designed connectors. This makes it possible, for example, to combine a Han[®] E male module that uses crimp terminations with a Han[®] E female module that uses the Push-In termination technique. This greatly increases your assembly options; the processing of the desired components can be adapted according to the number of pieces and your on-site conditions.

Features:

- Tool-free assembly
- Quick to assemble because the wire can be directly inserted into the contact chamber
- Wide range of conductor cross-sections: 0.14 – 6.0 mm² across all modules
- Can be assembled on-site with a screwdriver
- The inserts are plug-in compatible with similarly designed products of the same design that use other termination techniques.
- Cost savings because of reduced assembly time of up to 30%

3. Assembly

The assembly for the Han® Push-In inserts varies according to the different wire variants:

① Stranded wire



② Wire with wire ferrule



③ Solid wire



3.1 Assembly with stranded wires

1. When assembling the Han® Push-In module using stranded wires, first strip the insulation from the strands according to Table 1.

Table VII-1: Stripping lengths

Module variant	Stripping length [mm]
Han DD® module	10
Han E® module	10
Han EE® module	10
Han® C Module	12
Han® CC protected module	12

2. Press down the orange actuator before inserting the wire.

- ▶ The cage clamp opens so that none of the strands get deformed during insertion.

3. After inserting the stranded wire, release the actuator.

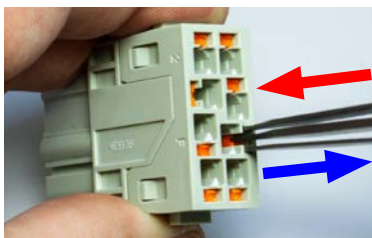
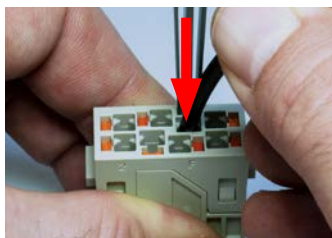
- ▶ The electrical connection is established and the assembly is finished.

You can further simplify the assembly process by using the Han® Push-In tool (09 99 000 1002). Use this tool to lock the actuator in its depressed position – you can now insert the wire without resistance.



Figure VII-2: Han® Push-In tool (09 99 000 1002)

4. Press the spring-loaded blades of the Han® Push-In tool together and position them centrally at the corresponding actuator.
5. When pressing down the actuator, let the spring-loaded blades slide along the contact chamber wall.
 - ▶ After you've reached the end point, the tool springs open automatically and the actuator is latched in. You can now insert the stripped stranded wire into the contact chamber. Press the spring-loaded blades together again to retract and remove the tool.



VII

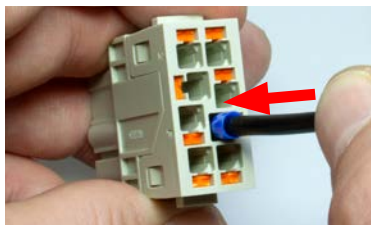


Figure VIII-3: Spring-loaded blade in the contact chamber (⇒ Chap. 3.1, ④ + ⑤) and tool-free assembly with wire ferrule

3.2 Assembly with wire ferrules (insulated/uninsulated)

1. Attach the wire ferrules to the stranded wires.
2. Guide the stiffened strands into the contact chamber and push the wire ferrule past the cage clamp.
 - ▶ Check the tightness of the wire by pulling on it slightly.
 - ▶ If it is secure, the electrical connection is established and the assembly is completed.

3.3 Assembly using solid wires

The assembly process using solid wires is similar to the process with wire ferrules (⇒ Chapter 3.2).

VIII. Han-Quick Lock®

Table of contents

1. Radial cage-clamp.....	128
2. Cage-clamp terminal and Han-Quick Lock®.....	128
3. Useable cable types.....	129
4. Advantages	130
5. Application areas	130
6. Normative requirements	131
7. Technical details	131
7.1 Stripping lengths, cable cross-sections.....	131
7.2 Micro-sections	132
8. Series with Han-Quick Lock®	133
9. Suitable tools	135
10. Assembly instructions.....	135
10.1 Assembly	135
10.2 Removal	136

1. Radial cage-clamp

To allow for quick assembly of connectors in the field, HARTING has developed the radial cage-clamp technology under the name Han-Quick Lock®. This termination technique combines the reliability and ease of use of the standard cage-clamp termination with the minimal space requirement of the crimp technology. It is the only termination technique that can be pre-assembled as well as assembled on-site achieving a contact density comparable to crimp termination.

Features:

- Quick, simple and robust termination technology
- Can be assembled on-site with a screwdriver
- Resistant to shock and vibration just like a standard cage-clamp termination
- Mating compatibility with many inserts and modules of the Han® connector series

VIII

2. Cage-clamp terminal and Han-Quick Lock®

Figure VIII-1 describes the core of the Han-Quick Lock® termination. It is easy to see what makes the termination technology reliable: The spring (round clamp spring) encloses the stranded wire and clamps it *radially*.

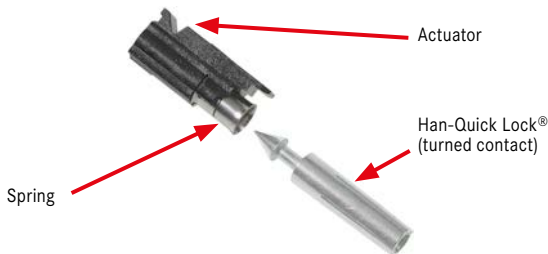
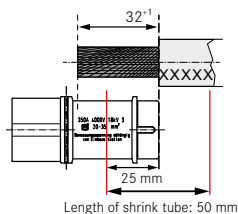


Figure VIII-1: Actuator and radial clamp of the Han-Quick Lock®



= Horizontally movable
spring tension
(active clamp spring)

Figure VIII-2: Cage-clamp termination



= Radially movable spring tension
(active clamp spring)

VIII

Figure VIII-3: Han-Quick Lock® contact

Figures VIII-2 and VIII-3 show the different directions of the spring clamp of the cage-clamp termination and Han-Quick Lock® termination technology.

3. Useable cable types

The termination technology allows the use of fine-stranded wires according to IEC 60228 (VDE 0295) class 5 (refer to Chapter IV, Table IV-1, p. 30), which corresponds to standard stranded wires.

The following is *not* to be processed:

- Solid wire



- Stranded wire with only a few single strands



- Twisted wire



4. Advantages

- Time saving: a time saving of 20% is achieved with the use of Han-Quick Lock® compared to the traditional screw termination technique.
- Vibration resistance: stranded wires terminated with Han-Quick Lock® meet the high demands of the transport industry (shock and vibration test according to DIN EN 61373).
- Wire retention force: The required minimum values as specified in DIN EN 60352-7 have been greatly exceeded (refer to Figure VII-4).
- *Contact resistance*: Results from the climatic test and the multi-component industrial gas test show that the *contact resistance* of the Han-Quick Lock® terminations is significantly below the max. permitted values specified in DIN EN 60352-7.

5. Application areas

Connectors with Han-Quick Lock® contacts are used in a wide variety of electronic and electrical applications. The degree of protection of the housing complies with international standard IEC 60529 and IEC 60529. The application areas include:

- Energy installations
- Industrial instrumentation
- Robotics
- Conveyor equipment
- Chemical installations
- Electrical cabinet manufacturers
- Machine controls
- Injection moulding machines

6. Normative requirements

The conditions for the set-up and testing of radial clamps are specified in the standard DIN EN 60352-7 similar to the standard cage-clamp.

Wire pull-out forces

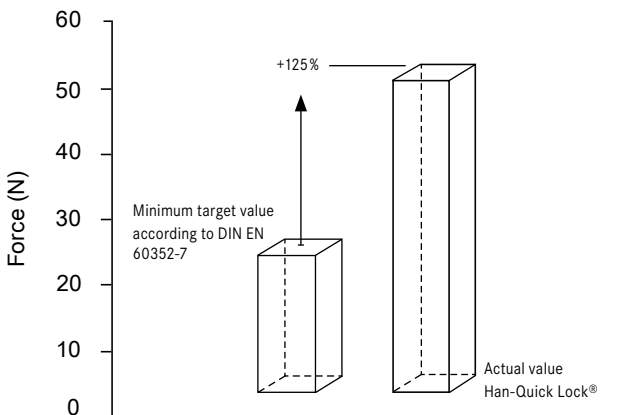


Figure VIII-4: Wire pull-out forces with cable cross-section 0.5 mm^2

7. Technical details

7.1 Stripping lengths, cable cross-sections

Table VIII-1: Technical characteristics of Han-Quick Lock® termination technology

Maximum cable diameter	3.6 mm
Terminal cross-section	0.25 – 1.5 mm ² / AWG 23 – 16 (black slide actuator) 0.5 – 2.5 mm ² / AWG 20 – 14 (blue slide actuator)
Stripping length	10 mm
Can be rewired without damage	≤ 10 contact assemblies

7.2 Micro-sections

X-ray images allow a view of the interior of the Han-Quick Lock® termination technology: Figure 1 shows the spring on the cone, Figure 2 shows a close-up of the spring, Figure 3 shows the interaction between stranded wires, cone and spring (refer to Figure VII-5).



Figure VIII-5: X-ray images of Han-Quick Lock®

8. Series with Han-Quick Lock®

Table VIII-2: Connector series with Han-Quick Lock® termination technology

Series	Power (0.5 – 2.5 mm ²)		Signal (0.25 – 1.5 mm ²)	
	Part no.	Product	Part no.	Product
Han® PushPull	09352320401	Han® PushPull Power 4/0-F Metal QL	09352340401	Han® PushPull Power 4/0-F Metal QL 1.5 mm ²
	09352320311	Han® PushPull PFT Metal rectangular QL power	09352340311	Han® PushPull PFT Metal rectangular QL power 1.5 mm ²
	09352320423	Han® PushPull Power 4/0-F QL AWG 20-14	09352340421	Han® PushPull Power 4/0-F Plastic QL 1.5 mm ²
	09352320331	Han® PushPull PFT Plastic rectangular QL power	09352340331	Han® PushPull PFT Plastic rectangular QL power 1.5 mm ²
Han A®	09200032733	Han® 3A-F-QL	09200032734	Han® 3A-F-QL 1.5 mm ²
	09200032633	Han® 3A-M-QL	09200032634	Han® 3A-M-QL 1.5 mm ²
	09200042733	Han® 4A-F-QL	09200042734	Han® 4A-F-QL 1.5 mm ²
	09200042633	Han® 4A-M-QL	09200042634	Han® 4A-M-QL 1.5 mm ²
Han D®			09210072732	Han® 7 D-F Quick Lock 0.3 – 1.5 mm ²
			09210072632	Han® 7 D-M Quick Lock 0.3 – 1.5 mm ²
			09360082732	Han® 8 D-F Quick Lock 0.3 – 1.5 mm ²
			09360082632	Han® 8 D-M Quick Lock 0.3 – 1.5 mm ²
Han® Q			09120062762	Han® Q4/2 F-AS-QL 2.5-6 mm ²
			09120062662	Han® Q4/2-M-AS-QL 2.5-6 mm ²
			09120062763	Han® Q4/2 F-AS-QL
			09120062663	Han® Q4/2-M-AS-QL

Series	Power (0.5 – 2.5 mm ²)		Signal (0.25 – 1.5 mm ²)	
	Part no.	Product	Part no.	Product
Han® Q	09120052733	Han® Q5/0-F-QL	09120052734	Han® Q5/0-F-QL 1.5 mm ²
	09120052633	Han® Q5/0-M-QL	09120052634	Han® Q5/0-M-QL 1.5 mm ²
	09120082733	Han® Q8/0-F-QL	09120082734	Han® Q8/0-F-QL 1.5 mm ²
	09120082633	Han® Q8/0-M-QL	09120082634	Han® Q8/0-M-QL 1.5 mm ²
			09120123101	Han® Q 12-F-QL
			09120123001	Han® Q 12-M-QL
Han-Modular®	09140062733	Han® E Quick Lock Module, female	09140122732	Han DD® Quick Lock Module, female
	09140062633	Han® E Quick Lock Module, male	09140122632	Han DD® Quick Lock Module, male
	09140082733	Han® EE Quick Lock Module, female	09140122734	Han DD® Quick Lock Module, male Au
	09140082633	Han® EE Quick Lock Module, male	09140122634	Han DD® Quick Lock Module, male Au
			09140082734	Han® EE Quick Lock Module, female 1.5 mm ²
			09140082634	Han® EE Quick Lock Module, male 1.5 mm ²
Han-Yellock®	11051052633	Han-Yellock® Module-M-QL 20A	11051052634	Han-Yellock® male carrier QL 10A, 1.5 mm ²

9. Suitable tools

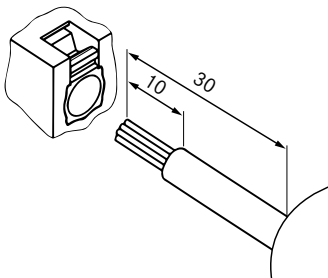
Table VIII-3: Suitable tool for Han-Quick Lock® termination technology

Screwdriver	0.4 x 2.5 mm
Screwdriver	0.5 x 3.0 mm

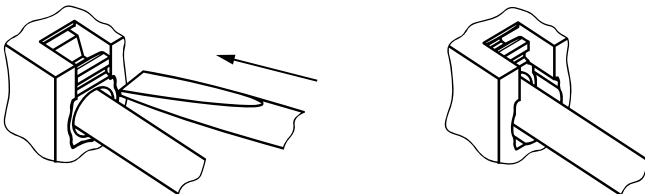
10. Assembly instructions

10.1 Assembly

1. Remove the cable sheath and strip the *stranded wires*.

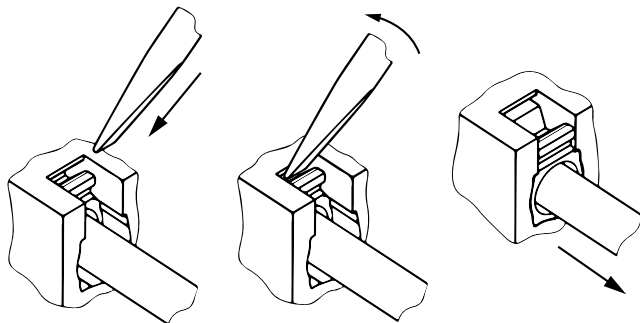


2. Push the *stranded wire* into the Han-Quick Lock® contact chamber and push the actuator in all the way using a screwdriver. Meanwhile, push the stranded wire further into the contact chamber!



10.2 Removal

Insert the screwdriver at an angle of 45° into the opening of the coloured actuator intended for this purpose and lever the actuator out. Then remove the *stranded wire* from the contact chamber.



VIII

Notice:

You can find a video film with assembly instructions for Han-Quick Lock® on the Internet under:

<http://www.harting.com/service/videos/video-presentationen/>

IX. Solder termination technology

Table of contents

1. Introduction	138
2. Soldering method.....	139
2.1 Wave soldering.....	139
2.2 Reflow soldering	140
3. Soldering bath temperatures for wave soldering.....	141
4. Solder	141
5. Soldering profiles.....	142
6. HARTING THR/SMT	143
7. Standards	148
8. Product portfolio of HARTING connectors for soldering/THR/SMT.....	150

1. Introduction

Soldering is a thermal process for firmly joining and bonding materials, whereby a liquid phase is produced by melting a solder (reflow soldering) or by diffusion at the interfaces (diffusion soldering). The melting point of the base metals is not reached (extract from DIN 8505).

A distinction is made in soldering between soft-soldering and brazing. Soft-soldering refers to a temperature of up to 450°C. Above this, up to 900°C, the soldering process is referred to as brazing.

The components produced by HARTING are soft-soldered.

In the case of soldering, a non-detachable, firmly bonded connection is produced between the same (e.g. copper with copper) or different materials (e.g. copper with silver) using solder. The solder is an easily fusible metal alloy consisting mainly of tin and other metals such as copper or silver, and serves as a bonding material. The goal is a solid electrical connection between two metal components. The components produced by HARTING for solder termination technology on the PCB and on the cable side can be processed using all the established and recognised soldering processes. The different soldering processes are described below.

IX

Further information on electronic assemblies are contained in IPC A 610. This directive lays down this general acceptance criterion. Publisher of the German translation is the Professional Electronic Design Association (FED).

Due to the environmentally hazardous properties and the associated risks to health, since 1 July 2006, lead (Pb) may no longer be used above certain concentrations in materials in the electronics field. The corresponding directive is *RoHS 2011/65/EU (RoHS 2)* issued by the EU. All HARTING products comply with *RoHS 2* and are suitable for the higher soldering temperatures prescribed therein.

2. Soldering method

Common soldering methods include:

- wave soldering (flow soldering)
- reflow soldering

2.1 Wave soldering

Wave or flow soldering is a technology for implementing electronic circuits on printed circuit boards. The printed circuit board moves on a travelling transport system at a uniform speed through the soldering machine.

The assembled PCB passes through the flux station (*spray or foam fluxer*) at the beginning of the wave soldering system. The pre-heating zone follows, in which the solvent contained in the fluxer is evaporated.

The pre-heating station is followed by the actual wave solder bath, in which the soldering operation is carried out. The tin solder is heated to above the melting point and continuously pumped over an edge in a molten (liquid) state, so that the flow (wave) necessary for soldering is generated. The printed circuit board is moved through this solder flow, so that the solder wave touches its underside. The tin solder can rise only by capillary action into the holes.

IX

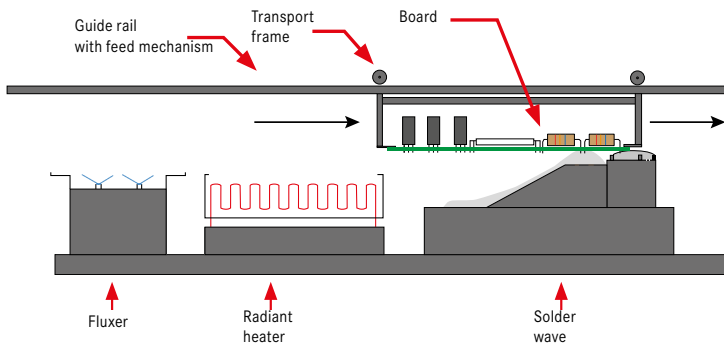


Figure IX-1: Principle of wave soldering

2.2 Reflow soldering

The term reflow soldering describes a common soft soldering process in electrical engineering for soldering *SMT* and *THR* components.

In the first step of reflow soldering, the (soft) solder is applied in the form of solder paste to the circuit board prior to assembly. There are several ways to apply the solder, for example, by stencil printing (screen printing) or *dispensers*.

The components are attached in the next step: since solder paste is sticky, the components adhere directly to it during assembly. When the solder melts, the assembled components are centered by the surface tension on the land pads.

Conventional reflow soldering

With convection soldering and vacuum soldering, PCBs are soldered in continuous flow soldering passages. A conveyor system moves the part to be soldered through a furnace. The soldering process can be controlled by the dwell time in the various temperature zones.

Typically, the part to be soldered moves through four zones:

1. Heating zone
2. Activation zone of the flux (*fluxer*)
3. Soldering zone
4. Cooling zone

Convection soldering

During convection soldering, air is heated and passes through nozzles to the part to be soldered, whereby the heat is distributed uniformly. Alternatively, an inert gas such as nitrogen can be used. This prevents oxidation.

Vacuum soldering

During vacuum soldering (which has no voids or flux), heat is transferred in a vacuum by radiation (infrared) or by direct physical contact (contact soldering). The lowered pressure at temperatures up to 450 °C avoids oxidation and simplifies the controlled addition of the process gases.

Vapour phase soldering (condensation soldering)

This soldering method comes relatively close to being the ideal soldering method. It is used for soldering *SMT* and *THR* components, which are put in the solder paste.

SMT – *Surface Mount Technology* – describes a component that is soldered only on the surface using the reflow process.

THR – *Through Hole Reflow* – describes a component that is soldered using the reflow process, but still has pins for fixing through the board.

A liquid is heated to its boiling point and changes from a liquid to a gaseous state. The resulting vapour does not get hotter than the boiling point of the liquid medium and spreads itself uniformly by its nature.

Therefore, all the solder joints have exactly the same preset correct soldering temperature, which is determined by the gas.

3. Soldering bath temperatures for wave soldering

Lead-free (*RoHS-compliant*) solders have a higher melting point and thus a higher processing temperature. These values for the respective alloys can be found in Table IX-1.

Table IX-1: Melting and processing temperatures for solder alloys

Alloy	Melting temperature °C	Processing temperature °C
Tin-silver (Sn96 Ag4)	221	265
Tin-copper (Sn99 Cu1)	227	270
Tin-silver-copper (Sn95.5 Ag3.8 Cu 0.71)	217	260

IX

4. Solder

Soldering generally involves alloys of different metals. The melting point of the alloy is lower than that of the individual metals. Before soldering, the parts to be joined must be properly cleaned chemically. Flux removes the oxide layer on the metals and protect them against renewed oxidation. Because the tensile strength of the solder is lower than that of the materials to be joined, the solder layer should be as thin as possible for soldered connections.

Table IX-2: Overview of soldering temperatures

Solder alloy	Melting point °C	Solder temperature / Standard reflow °C	Solder temperature / Vapour phase soldering °C	RoHS-compliant	Remarks
Sn96 Ag4	221	approx. 245	230	yes	can be processed using both methods
Sn99 Cu1	227	approx. 250	not reliably possible	yes	can only be processed with higher temperatures
Sn 95.5 Ag 3.8 Cu 0.71	217	approx. 240	230	yes	can be processed using both methods
Sn 69.5 Ag 3.0 Cu 0.5	217–221	approx. 240	230	yes	can be processed using both methods
Sn60 Pb40	183–190	approx. 210	200	no	contains lead

Notice:

Different alloys are used for different application areas. When making repairs, ensure that you use the same solder alloy as used during manufacture. Otherwise, a solder with a melting point that is too low can be created, so the assembly no longer has the required working life and/or the required operational safety.

IX

5. Soldering profiles

A soldering profile shows the temperature curve during soldering as a function of time (temperature-time graph). Solder profiles show how components can be safely processed during the soldering process.

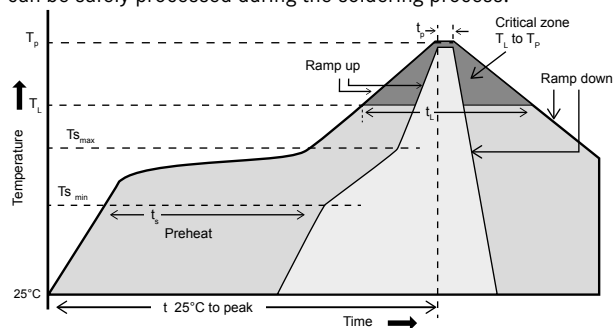


Figure IX-2: Soldering profile measured on the component, acc. to IPC-Jedec J-Std 020C

The peak temperature (T_p) can be up to 260°C according to the JEDEC and the peak time (t_p) can be up to 40 sec.

Figure IX-3 shows a commonly used soldering profile in practice (for reflow soldering). The temperature profiles shown here and also the peak temperature are used today by most electronics manufacturers.

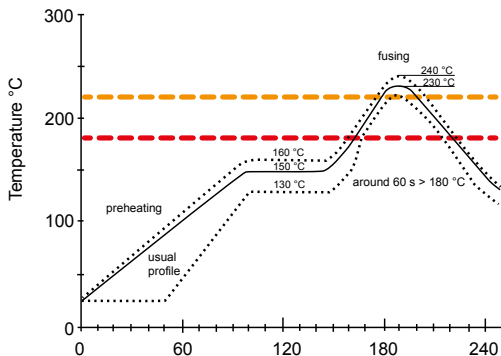


Figure IX-3: Soldering profile for reflow soldering (temperature at the solder joint)

6. HARTING THR/SMT

The continuing trend towards miniaturisation has revolutionised the assembly of electronic components. Since the 1990s, most components have been mounted directly to the circuit board surface using *Surface Mount Technology (SMT)*. By eliminating the mounting holes in the circuit board, a space savings of up to 70 percent is achieved.

Conventional parts such as ICs, resistors, capacitors and coils are now processed in mass production almost exclusively using *SMT*.

THR technology*

With *THR* technology, the connector is inserted into plated-through holes in the same way as with standard component assembly. All other components can be mounted on the circuit board surface. Placement of the components is carried out with so-called pick-and-place machines. A distinction is made between machines for small and light or those for bulky components. Unlike ICs, connectors are considered to be bulky components, because they are more difficult to access due to their comparatively heavy weight and volume.

Pick-and-place machines for bulky components must also have higher setting forces to fit the components in the PCB holes filled with solder paste. Normally, both machine types are available in a modern *SMT* production line. Therefore, the user usually has no further investment costs with this technology.

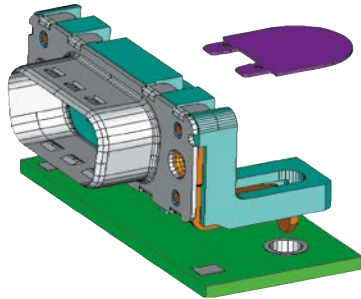


Figure IX-4: D-Sub THR connector

* Through Hole Reflow (THR) technology: Also known as *Pin-in-Hole Intrusive Reflow* or *Pin-in-Paste technology*

IX

Assembly process for conventional assembly

1. Applying the solder paste
2. Positioning the components
3. Positioning of bulky components
4. Reflow soldering
5. Press-in operations or partial dip soldering the connector at the panel edge
6. Quality control



Figure IX-5: Pick-and-place machine with vacuum pipette and D-Sub

THR connectors have been specially developed for use in the *THR* process. In addition to the preferred black colour of the insulation body used for automatic assembly and machine-friendly packaging, the connectors also offer snap-in clips for attaching to the printed circuit board before soldering.

The open design of the insulation body made of high temperature resistant plastic ensures homogeneous heat distribution, so that existing soldering profiles can be maintained. The connectors are suitable for even higher temperatures, for example, for lead-free soldering processes.

Advantages of THR connectors:

- Partial dip soldering or press-in operations are unnecessary
- High mechanical stability
- Compatible with surface mount technology
- Cost savings through integration into the automated assembly process
- No additional space requirements within the production facility

Application of solder paste

Before the components are placed, all solder pads and plated through-holes are provided with solder paste. Screen printing is the method usually used for this. A squeegee moves across the PCB which is masked with screens and presses the solder paste into all unmasked areas. Good soldering depends essentially on the filled paste volume. This can be calculated using the formula on the next page.

An alternative to the screen printing process is to apply the solder paste using a dispenser. With this method, the paste is applied using a pipette. A high-precision robot moves the dispenser individually and consecutively to all required locations on the circuit board.

The dispensing method is particularly suitable for small PCBs or applications where high precision and flexible dispensing volumes are required.

Solder paste volume

A variety of scientific studies deal with calculating the required quantity of solder paste. Here, the different parameters are included in the analysis, for example, the shrinking factor of the paste during soldering or the thickness of the screens used for masking the PCB. Because these calculation methods are complicated to apply, the following rule of thumb has proven to be useful in practice:

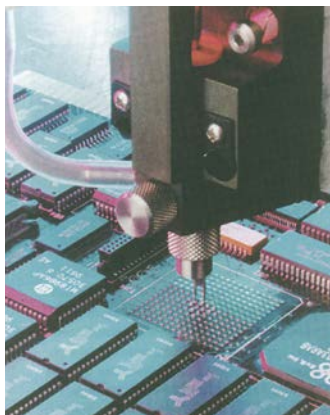


Figure IX-6: Dispenser in use

$$V_{\text{Paste}} = 2(V_{\text{H}} - V_{\text{P}})$$

with:

V_{Paste} = Required solder paste volume

V_{H} = Volume of the plated through-hole

V_{P} = Volume of the connector termination in the hole

Comment: The multiplier 2 compensates for the shrinking of the solder paste during soldering. The assumption was made that 50 percent of the solder paste consists of actual solder and 50 percent of an auxiliary solder product.

Requirements for the solder

At the beginning of a new production batch, process parameters such as solder paste and soldering temperature are set by interpreting simple *micro-sections* of the soldered joint. A reliable dimension for the optimum choice of parameters is the filling capacity of the solder in the hole. Soldered joints with good quality have a capacity between 75 and 100 percent.

IX

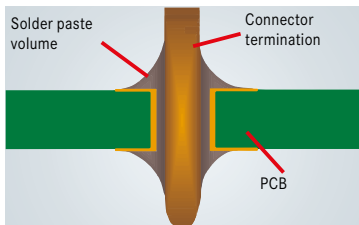
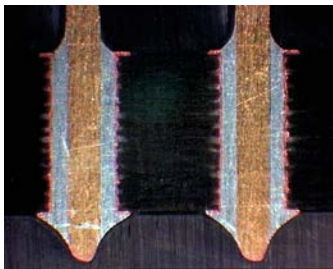


Figure IX-7: Plated through-hole with connector termination

Temperatures in the reflow process

With *SMT* and *THR* connectors, temperatures of up to 260 degrees Celsius must briefly occur on the components during the reflow process. Therefore, the insulation body must be made of a dimensionally stable plastic that when subject to heat expands in compliance with the PCB material.

HARTING THR technology

The length of the connector contacts should be sized so that they protrude by no more than 1.5 millimetres after they are inserted in the printed circuit board. Because each contact passing through the solder paste in the hole picks up solder on its tip, in the case of a larger contact length, it would no longer be able to flow back due to capillary action during the soldering process into the plated through-hole, thus impairing the quality of the solder joint.

The connector design must allow automatic assembly on pick-and-place machines as well as manual positioning for small and test batches. The machine-ready design of the delivery package is also important. Experience shows that individual chambers made of deep-drawing films, which are rolled up on rolls (reel packaging, tape & reel) and plastic tubes (tubes) are particularly suitable. Plastic trays are used for larger components.

HARTING offers its customers a complete system for integrating *THR* technology into existing production lines. The company produces a wide range of *THR* connectors (2, 3- and 5-row) according to IEC 60603-2, D-Sub connectors according to CECC 75301-802 and connectors from the SEK series with connector pitch of 1.27 mm. In addition, HARTING supports the market with packaging and processing concepts that were jointly developed with well-known manufacturers of THR soldering and pick-and-place facilities.

IX

For more detailed information on this termination technique, please refer to the chapter “THR – soldering technology” in the catalogue “HARTING Connectors DIN 41612”.

Advantages of pin-in-hole intrusive reflow technology:

- Partial dip soldering or press-in operations are unnecessary
- Full compatibility with *surface mount technology*
- Full integration into the automated assembly process
- No additional space requirements within the production facility
- Usually no additional investment costs



Figure IX-8: SEK connectors in machine-ready packaging

7. Standards

This chapter deals with all relevant soldering standards, guidelines and test methods.

A properly executed solder joint is characterised by a reproducible, constant quality in terms of its mechanical and electrical characteristics. That makes this termination technique particularly interesting for the production of large production series.

To achieve these high quality characteristics, there are various standards and test methods. The most important standards and procedures for inspecting a solder joint are:

- IEC 60068-2-69 – Environmental testing – Part 2-69: Tests: Solderability testing of electronic components and printed boards by the wetting balance method
- IPC-A-610 – Acceptance criteria for electronic assemblies
- IPC/JEDEC J-STD-020 – Moisture/Reflow Sensitivity Classification for Nonhermetic Surface Mount Devices (MSL)
- IPC EIA/JEDEC-J-STD-075 – Classification of Non-IC Electronic Components for Assembly Processes (PSL)

Solderability according to IEC 60068-2-69 – Environmental testing – Solderability testing of electronic components and printed boards by the wetting balance (force measurement) method

Solderability is the ability of a metal to accept the solder and to provide a firm and electrically conductive connection. The two standards mentioned above describe appropriate test methods. They differ mainly in the type of components to be soldered and their technique. A distinction is made between *THR* (through-hole components) and *SMT* technology (surface-mount components). The solderability is checked with a wetting test. Here, flux is applied to the solder connections which are then immersed for 5 seconds in a solder bath. The forces are recorded using a force transducer.

The recorded diagrams and the resulting characteristics gives an indication of the quality of the surface. Moreover, the submerged surface is examined under the microscope. Ideally, at least 95% of the submerged area should be wetted with solder.

Usually this test is performed with three sample states.

1. New contacts/components
2. Contacts/components after 16 hours of exposure at 155°C
3. Contacts/components after 8 hours of exposure to steam

Visual inspection of the finished solder joints IPC-A-610 – Acceptance criteria for electronic sub-assemblies

The IPC-A-610 is an internationally recognised quality standard that defines visual acceptance criteria for the production of electrical and electronic components. It refers to criteria that are outwardly visible; it is applicable to both *THR* and *SMT* soldering. This makes it one of the non-destructive test methods, because *cross-sections* are not needed. Expensive test equipment such as X-ray devices are not required.

The IPC-A-610 divides solder joints into three classes. Depending on the class, there may be differences in the acceptance criteria.

With a solder joint for a radio (Class 1), for example, less solder is needed in the plated through-hole than in a medical diagnostics device (Class 3).

Class 1: General Electronic Products

Class 2: Dedicated Service Electronic Products

Class 3: High Performance Electronic Products

IX

The illustration below shows faulty and proper solder joints, contrary to the standard, to better illustrate the micro-section.

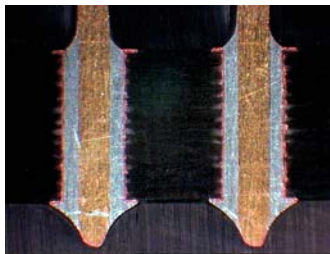


Figure IX-9: Properly soldered joint

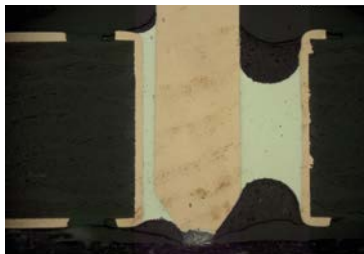


Figure IX-10: Soldered joint with marginal fill level

Reflow soldering capabilities in accordance with IPC/JEDEC J-STD-020 – Moisture/Reflow Sensitivity Classification for Nonhermetic Surface Mount Devices [⇒ moisture sensitivity level – MSL]

IPC EIA/JEDEC-J-STD-075 – Classification of Passive and Solid State Devices for Assembly Processes [⇒ process sensitivity level – PSL]

Components to be soldered in the reflow process must be suitable for the high temperatures in a reflow oven. This applies especially to the plastic components. The temperature resistance and moisture absorption during storage must be observed.

The IPC EIA/JEDEC-J-STD-075 defines here via the PSL level at which temperatures the insulator's plastic is suitable. The MSL according to IPC/JEDEC J-STD-020 specifies how hydrophilic (attractive for moisture) the insulator's plastic is. This moisture, which is penetrating into the plastic, has an impact on the material behaviour in the reflow oven. If the plastic has absorbed too much water, it causes bubbles during soldering and may burst and change its shape and properties.

Further information on normative requirements for soldered connections can be found in the list of standards.

IX 8. Product portfolio of HARTING connectors for soldering/THR/SMT

Table IX-3 gives you an overview of the HARTING products that are processed with solder connection technology. For more information, please refer to the corresponding catalogue (e.g. "HARTING Connectors DIN 41612").

Table IX-3: Overview of HARTING connectors for soldering/THR/SMT

Standard/ specification	Size	Number of poles	Type/ variant
Soldering			
IEC 60603-2	DIN 41612: B, 2B, 3B, C, 2C, 3C, D, E, F, 2F, F9, FM, H3, H15, H16, M, M flat, M invers, MH, O, 2Q, 3Q, R, 2R, 3R, R(HE11), RM	3-96	Female/male
IEC 61076-4-107 2,0	<i>har-link</i>	10	Female
IEC 61076-4-113	<i>har-bus</i> ® 64	160	Female/male
None	<i>har-flexicon</i> ®	2-25	Base strip / terminal block
IEC 60807	D-Sub	9-50	Female/male

Standard/ specification	Size	Number of poles	Type/ variant
None	D-Sub HD	15-78	Female/male
DIN 41652 T1	D-Sub Mixed	2-36	Female/male
None	D-Sub Filter	9-37	Female/male
None	D-Sub water-protected	9-50	Female/male
IEC 60603-7	RJ45	8	Female
IEC 60603-13	SEK	6-64	Male/female
IEC 61076-2-105	M5	3-4	Male/female
IEC 61076-2-114	M8	4	Female
IEC 61076-2-101 IEC 61076-2-109 IEC 61076-2-111	M12	4-8	Male/female
THR			
IEC 60603-2	DIN 41612: B, C, D, E, F	32-96	Male
IEC 60603-2	DIN 41612: 2B, 3B, 2C, 3C, 3Q, R, 2R, 3R	20-96	Male/female
IEC 60603-2	DIN 41612: Q, 2Q	32-64	Female
IEC 61076-4-113	<i>har-bus</i> [®] 64	160	Male
None	<i>har-flexicon</i> [®]	1-25	Base strip / terminal block
IEC 60603-13	SEK	6-64	Male/female
IEC 60807	D-Sub	9-50	Female/male
IEC 61076-4-101	<i>har-bus</i> [®] HM Power	4	Male
None	<i>har-flex</i> Signal & Power THR	2-100	Female/male
None	preLink [®]	8	Female
IEC 63171-6	T1 Industrial [®]	2	Female
SMT			
IEC 60807	D-Sub	9-37	Female/male
None	<i>har-flexicon</i> [®]	1-12	Base strip / terminal block
None	<i>har-flex</i>	2-140	Female/male
IEC 61076-3-124	ix Industrial [®]	8-10	Female
None	Mini DisplayPort	20	Female
IEC 61076-2-101 IEC 61076-2-109	M12	4-8	Male/female

X. Wire wrap termination

Table of contents

1. Introduction	154
2. Wrap types.....	155
3. Tools for the wire wrap technique	156

1. Introduction

Wire wrap technology does not currently play a major role in the industry. It is used occasionally in telecommunications for the wiring of electrical cabinets. The advantage here is that versatile contact connections can be established, even for large connection grids with many connectors. The wraps must simply be rewound in order to make changes. There is no need to change circuit boards or board layouts. For experienced production personnel, a simple data table should be sufficient to implement any changed requirements during production.

The advantage of the great versatility is offset by the disadvantage of the high cost in manufacturing. Since each connection is made individually by hand, the time and costs required, as well as the error rate are relatively high.

The wire wrap technique refers to the method of wrapping a wire several times around a squared terminal pin. The actual contact is established at the corners of this terminal pin.

When implemented properly, this connection has the following characteristics:

Electrical: minimal *contact resistance*

Mechanical: firm

Climatic: not sensitive

Thermal: stable

Some examples of this technique are shown in this chapter.

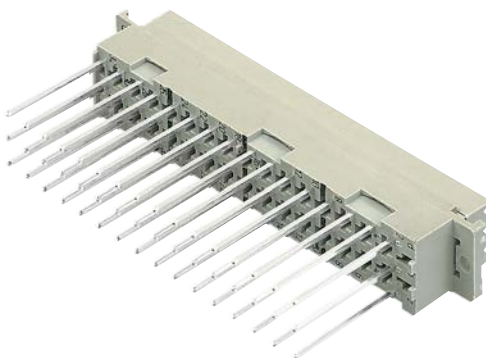


Figure X-1:
DIN 41612 type F with wrapping posts

2. Wrap types

The requirements for a finished wire-wrap connection, as well as the associated tests and recommendations for materials and dimensions, are specified in DIN EN 60352-1.

There are two types of wraps: a) Standard wrap
b) Modified wrap

- a) Standard wrap: Only the stripped wire end is wrapped around the pin. The advantage of this wrap type is that the diameter of the wrapped wire's insulation may fluctuate significantly

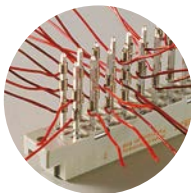


Fig. X-2: Standard wrap

X

- b) Modified wrap: An extra wrap is made which includes the wire insulation. The advantage of this wrapping type is that, in the event that the wire unwinds from the pin, no conductive wire material contacts the neighbouring wire wrap.

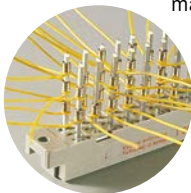


Fig. X-3: Modified wrap

3. Tools for the wire wrap technique

Special wrapping tools which operate pneumatically, electrically or manually, are used to achieve a precise wire wrap. These tools are equipped with wrapping inserts and guide sleeves, which support the wrapped wire and slip over the wrap pin.

The winding insert and guide sleeves to be used depend on the type of wrap, the wire and insulation diameters, and the dimensions of the wrapping (terminal) pins.

The following tables show the maximum number of wraps which (according to IEC 60352-1) may be applied to the wrapping pin.

Table X-1: Standard wrap

Valid for standard wraps		Diameter of wrapped wire (mm)						
		0.25	0.32	0.4	0.5	0.65	0.8	1.0
		Max. permitted diameter of wrapped wire, including insulation (mm)						
		0.7	0.9	1.17	1.27	1.32	1.5	1.78
		Min. required number of wraps per wrapping pin (for the stripped wire)						
		7	7	6	5	4	4	4
Dimension of the wrapping pin (mm)	Length of the wrapping pin (mm)	Possible number of wraps per wrapping pin						
0.6 x 0.6	13	6	5	4	4	4	3	2
0.6 x 0.6	17	8	6	6	5	5	4	3
1 x 1	20	10	7	7	6	6	5	4
1 x 1	22	11	8	7	7	6	5	4

Table IX-2: Modified wrap

Valid for modified wraps		Diameter of wrapped wire (mm)						
		0.25	0.32	0.4	0.5	0.65	0.8	1.0
		Max. permitted diameter of wrapped wire, including insulation (mm)						
		0.7	0.9	1.17	1.27	1.32	1.5	1.78
		Min. required number of wraps per wrapping pin (for the stripped wire)						
		7	7	6	5	4	4	4
Dimension of the wrapping pin (mm)	Length of the wrapping pin (mm)	Possible number of wraps per wrapping pin						
0.6 x 0.6	13	4	3	2	2	2	2	1
0.6 x 0.6	17	5	4	3	3	3	2	2
1 x 1	20	6	4	4	3	3	3	2
1 x 1	22	6	5	4	4	4	3	2

XI. Insulation displacement termination technology

Table of contents

1. Introduction	158
1.1 Overview of the insulation displacement connection	158
1.2 Industrial connectors	159
2. Assembly instructions.....	160
2.1 Assembly instructions for Han® 3A with HARAX®	160
2.2 Assembly instructions for unshielded HARAX® M8/M12	161
2.3 Assembly instructions for shielded HARAX® M12.....	162
2.4 Assembly instructions for M12 Slim Design IDC.....	163
3. Interface connectors.....	169
3.1 D-Sub standard	169
3.2 SEK	169
3.3 DIN 41612 connectors	171
3.4 Tools for interface and DIN 41612 connectors	172
3.5 Ethernet interfaces	173
3.6 Assembly instructions for HARTING RJ Industrial® 10G IP65 / 67	178
3.7 preLink® RJ45/M12 connectors and sockets	187
3.8 HARTING ix Industrial®	190
4. Piercing termination technique	196
4.1 Piercing termination overview.....	196
4.2 Assembly instructions HARTING RJ Industrial® Gigalink Cat. 6A IP20...	197

1. Introduction

1.1 Overview of the insulation displacement connection

IDC (insulation displacement connection) is a solder-free electrical connection technique. An non-stripped single wire is pressed into a downwardly tapered cutting terminal, thus establishing a conductive electrical connection. This connection is established as the cutting terminal cuts through the wire insulation. The inner wire core is then shaped so that a gas-tight connection is created that is resistant to corrosion. This wire termination technique has been used in the data and telecommunications industry since 1970. It can be used for both solid round wires or stranded wires.

In an optimal insulation displacement connection, the individual wire cores are deformed (as shown in Figure XI-1) so that they support each other.

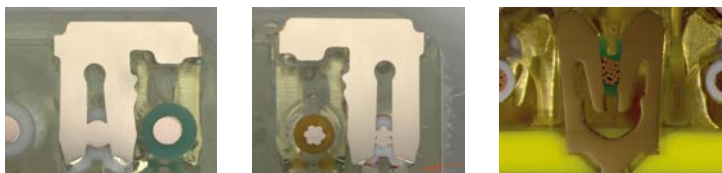


Figure XI-1:

Optimal insulation displacement connection for rigid and flexible (stranded) wires

XI

Figures XI-2 and XI-3 show poor insulation displacement connections. Here, the individual wires are insufficiently deformed; they do not support each other.



Figures XI-2 and XI-3:

Poor insulation displacement connections

Standards

The following standards apply to insulation displacement connections:

- EN 60352-3 Solderless electrical connections, part 3: solder-free accessible insulation displacement connections
- EN 60352-4 Solder-free electrical connections, part 4: solder-free non-accessible insulation displacement connections

The following chapters describe the assembly instructions for HARTING components that use insulation displacement terminals. More detailed product information can be found in the corresponding catalogues.

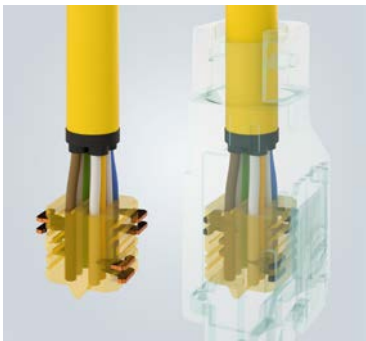
For the part numbers listed below, when an x is used in a part number, it is a placeholder for any valid digit.

1.2 Industrial connectors

For HARTING's industrial connectors, insulation displacement technology is used for the following connector types:

- Han[®] 3 A with HARAX[®]
- HARAX[®] M8/M12 circular connectors
- HARAX[®] panel feed throughs, in PG and metric
- HARTING RJ Industrial[®] RJ45 connectors and sockets
- preLink[®] RJ45/M12 connectors and sockets
- SEK connector systems
- DIN 41612 connectors
- D-Sub connectors
- HARTING ix Industrial[®]

XI



preLink[®] termination technique, with transparent terminal module

2. Assembly instructions

2.1 Assembly instructions for Han® 3A with HARAX®

Part number:
09 20 003 044x
male/female



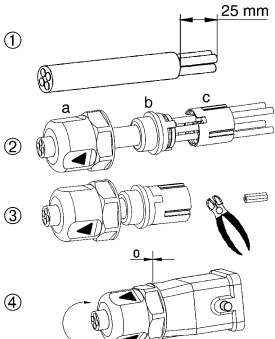
Figure XI-4: Han® 3A with HARAX® elements

Table XI-1: Technical characteristics

Wire cross-section/ Wire gauge	0.75–1.5 mm ²
Cable diameter	6.0 – 9.0 mm
Wire diameter	≤ 2.8 mm
Diameter of single wire	≥ 0.2 mm
Wire insulation material	PVC
Tightening torque for fitting nut	8.0 Nm

XI

Assembly

	1. Remove cable sheath
	2. Put on the HARAX® elements
	3. Snap in the seal insert and the splice ring. Cut off the wire ends.
	4. Screw in the fitting nut until it reaches the detents.
	a = Fitting nut b = Seal insert c = Splice ring
	The fitting nut, seal and splice ring are included in delivery.
	They can be re-connected ten times.

2.2 Assembly instructions for unshielded HARAX® M8/M12

Part numbers:

21 02 151 xx05	HARAX® M8 straight version, 3-/4-poles
21 03 111 x405	HARAX® M12 straight version, 4-poles
21 01 1x0 50x1	HARAX® M12 angled version, 3-/4-poles
21 03 212 xx0x	HARAX® M12-L straight version



Figure XI-5: HARAX® M8



Figure XI-6: HARAX® M12



Figure XI-7: HARAX® M12 angled



Figure XI-8: HARAX® M12-L

Table X-2: Technical characteristics

	M8 / M12	M12 angled	M12-L
Wire gauge	0.14 – 0.34 mm ² AWG 26 – 22	0.25 – 0.5 mm ² AWG 24/7 – 22	0.34 – 0.75 mm ² AWG 22 – 18
Wire strand diameter	≥ 0.1 mm	≥ 0.1 mm	≥ 0.1 mm
Wire insulation material	PVC/PP/TPE	PVC	PVC
Wire diameter	1.0 – 1.6 mm	1.2 – 1.6 mm	1.6 – 2.0 mm
Cable diameter	M8: 3.2–5.4 mm M12: 4.0–5.1 mm	4.0 – 5.1 mm	5.5 – 8 mm

XI

Assembly

	<ol style="list-style-type: none"> 1. Remove cable sheath 2. Put on HARAX® elements 3. Cut off wire ends 4. Screw on
	<p>Ⓐ Fitting nut Ⓑ Strain relief Ⓒ Splice ring</p>
	<p>Screw the fitting nut in until it reaches the end stop on the insert.</p>
	<p>Attention! Cut off any used cable ends before further usage. Repeat steps 1 to 4.</p>

2.3 Assembly instructions for shielded HARAX® M12

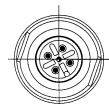
Part number:
21 03 2x1 xx0x
HARAX® M12-L shielded



Figure XI-9: HARAX® M12-L shielded

Table XI-3: Technical characteristics

	M12-L	M12-L Ethernet	M12-L Profibus
Wire gauge	0.25–0.34 mm ² AWG 24 – 22	0.25–0.34 mm ² AWG 24 – 22	0.25–0.34 mm ² AWG 24 – 22
Wire strand diameter	≥ 0.1 mm	≥ 0.1 mm	≥ 0.1 mm
Wire insulation material	PVC	PVC	PVC
Wire diameter	1.6 – 2.0 mm	1.2 – 1.6 mm	2.0 – 2.6 mm
Cable diameter	7.0 – 8.8 mm	5.5 – 7.2 mm	7.0 – 8.8 mm
Coding	A	D	B



4-pole
A-coding



2-pole, Profibus,
B-coding



4-pole, Ethernet,
D-coding

Figure XI-10: View of mating side,
male: HARAX® M12-L, shielded

Assembly

1.	1. Remove cable sheath
2.	2. Push the fitting nut and seal over the cable sheath. Spread the screening braid out. Insert the wires in the splice ring.
3.	3. Push the connector on the splice ring.
4.	4. Screw on the fitting nut until it stops.
	(a) Fitting nut (b) Strain relief (c) Splice ring
	Attention! Cut off the used cable ends before reuse. Repeat steps 1 through 4.

2.4 Assembly instructions for M12 Slim Design IDC

Part numbers: 21 03 3x2 x40x, M12 Slim Design D-coded IDC
 21 12 283 x8xx, M12 Medium Design X-coded IDC


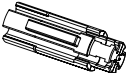

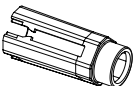
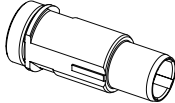


Figure XI-11: Medium Design X-coded IDC and M12 Slim Design D-coded IDC

	M12 Slim Design IDC	M12 Medium Design IDC
Approvals	IEC 61076-2-101	IEC 61076-2-109
Wire cross-section/ Wire gauge	AWG26, AWG22	AWG 26 - AWG 23
Wire strand diameter	≥ 0.1 mm	≥ 0.1 mm
Wire insulation material	PVC	PVC
Cable diameter	4.5 -8.8 mm	5.7 -11.6 mm
Coding	D	X

Components

Frame of seals	
Fitting nut	

Shielding element	
Contact holder	
Assembly aid	
Insert	
Cable Connector Housing	

XI Assembly steps

1. Select a suitable seal from the seal comb (Figure XI-12).

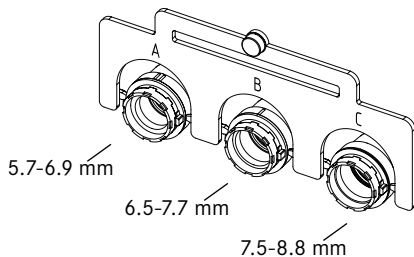


Figure XI-12

Please follow our specifications according to the following table:

Manufacturer	Description	Seal
Leoni/Studer	HARTING Ha-VIS EtherRail® CAT5 LSZH 4xAWG22/7	small seal (A)
Leoni/Studer	BETATRANS DATA C-Flex 100 OHM CAT5 FOAM 1x4xAWG	small seal (A)
H+S	H+S 12568935-725780 DATABUS 100 OHM CAT5 COM 4X22AWG	middle seal (B)
Leoni/Studer	HARTING Ha-VIS EtherRail® CAT5 LSZH 4xAWG22/19	middle seal (B)
Nexans	FLAMEX Quad 100 Ω - ETHERNET CAT 5 0.5 mm ²	big seal (C)

- Slide the fitting nut and selected seal onto the cable (Figure XI-13).

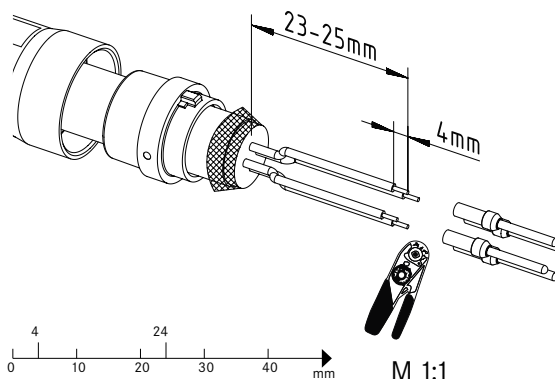


Figure XI-13

- Remove the cable sheath (Figure XI-13).
- Pull the screening braid back. Remove the foils if necessary (Figure XI-13).
- Remove the wire insulation. Crimp on the contacts (Figure XI-13).

Tools/materials:

D-Sub manual crimping tool:	09 99 000 0501
Locator:	09 99 000 0531
Contacts:	09 67 000 3576 AWG 22-18
	09 67 000 8576 AWG 24-20
	09 67 000 5576 AWG 26-22

Part number	AWG	Tool setting
09 67 000 3576	18	6
	20	6
	22	5
09 67 000 8576	20, 22, 24	6
09 67 000 5576	22, 24, 26	6

6. Place the shielding element on the seal. The shielding braid must lie between the seal and the shielding element. It must never get between the seal and the cable (Figure XI-14).

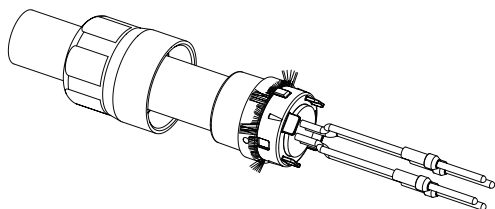


Figure XI-14

7. Insert the contacts sideways into the contact carrier. (Figure XI-15). Use the coloured identification marks on the contact carrier for the pin assignments.

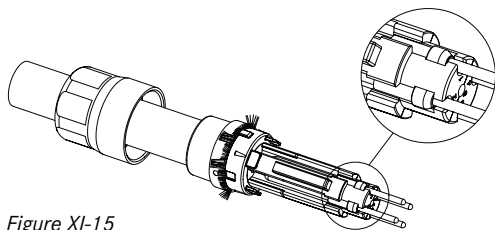


Figure XI-15

- Put on the assembly aid (Figure XI-16).

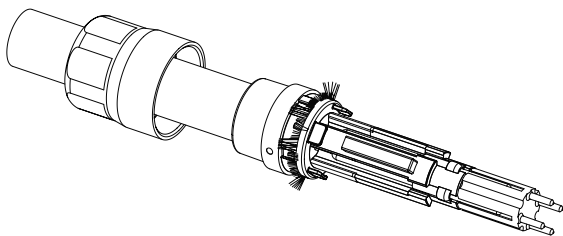


Figure XI-16

- Push the insulation body on until it clicks into place. Cut off the excess protruding shielding braid (Figure XI-17).

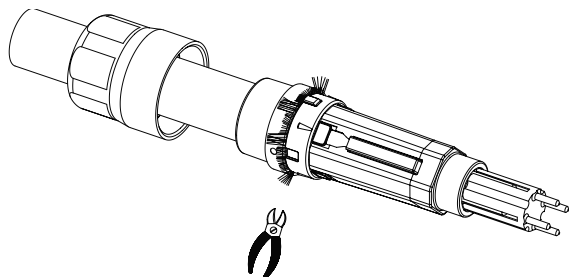


Figure XI-17

- Slide this assembly into the housing. Observe the coding (Figure XI-18).

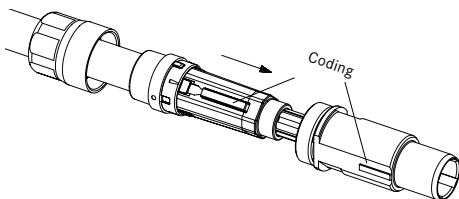


Figure XI-18

11. Screw the fitting nut all the way until it stops. Then remove the assembly aid (Figure XI-19).

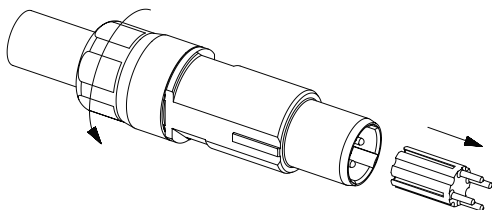


Figure XI-19

Caution! The seal insert must be replaced during the reassembly. The connector must not be plugged in or disconnected when it is live (when voltage is applied). To ensure a secure connection, a torque of 0.6 Nm must be applied to the knurled screw.

HARTING recommends using the M12 torque wrench 09 99 000 0646 for this.

3. Interface connectors

3.1 D-Sub standard

Part number:

09 66 x28 x70x Male connector (header) with shielding clip in protective metal collar

09 66 x18 x50x Female connectors (header) in protective metal collar



Figure XI-20: D-S D-Sub standard



Figure XI-21: Strain relief clamp

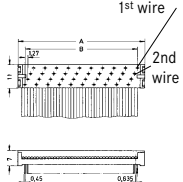

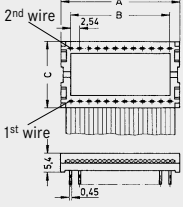

Table XI-5: Technical characteristics for D-Sub standard

Number of contacts:		9, 15, 25, 37
Connection pitch:		1.27 mm
Cross-section/wire gauge for connected wires	Stranded wires	AWG 28/7
		AWG 26/7
	Solid wires	AWG 30/1
		AWG 28/1

To connect the cable, use the appropriate tool for these inserts along with the corresponding accessories. Follow the assembly instructions that accompany the tools.

3.2 SEK


The SEK (insulation displacement technology) is a connector system with a 2.54 mm connector pitch. It is used to connect ribbon cables to circuit boards. A male connector (soldered to the circuit board) is used for the PCB connection. For the cable side, a female connector (with IDC) is used. The

Part number	Number of contacts	Con- nection pitch [mm]	Termina- tions*	Contact arrangement	Product photo
09 19 0xx 9643 PCB connector 4 rows	10, 16, 20, 26, 34, 40, 50	Cable side: 1,27 (0.050")	IDC ribbon cable in 1.27 mm (0.050") pitch AWG 28/7		
09 17 0xx 9622 Socket connector for IC socket or for soldering on circuit board	14, 16, 24, 28, 40	Cable side: 1,27 (0.050")	IDC ribbon cable in 1.27 mm (0.050") pitch AWG 28/7		

* Make sure that the colour coding is properly aligned when connecting the ribbon cable.

3.3 DIN 41612 connectors

Table XI-8: Overview of DIN 41612 connectors

Part number	Con- nection pitch mm	Electr. connection	Contact arrangement	Product photo
09 03 264 x828 Female con- nector 64-pole Size C	2,54	IDC AWG 28/7	Contacts in rows a+ c 1, 2, ..., 31, 32 Wire 1 of the ribbon cable on contact c1	

To connect the cable, use the appropriate tool for these inserts along with the corresponding accessories. Follow the assembly instructions that accompany the tools.

3.4 Tools for interface and DIN 41612 connectors

D-Sub

Table XI-9: Overview of tools and accessories

Part number	Tool	Accessories	Remarks
Connector Male connectors 09 66 x28 x70x Female connectors 09 66 x18 x50x	Lever press 09 99 000 0114	Support plate 09 99 000 0135	For processing ribbon cables
		Insert component 09 99 600 0201	For processing 37-pole male connectors

SEK

Table XI-10: Overview of tools and accessories

Part number	Tools	Accessories	Remarks
09 18 5xx x8xx Female connector with polarisation in middle	Lever press 09 99 000 0114	Support plate 09 99 000 0115	For female connectors
09 18 1xx 9621 Standard version		Support plate 09 99 000 0134	For DIP
09 18 1xx 9421 Kinked version (2 kinked contacts/side)		Support plate 09 99 000 0131	For circuit board, 2 rows
09 19 0xx 9643 PCB connector 4 rows		Support plate 09 99 000 0130	For circuit board, 4 rows
09 17 0xx 9622 Socket connector for IC socket or for soldering on circuit board		Support plate 09 99 000 0150	For DIN 41612

DIN 41612

Table XI-11: Overview of tools and accessories DIN 41612

Connector	Tool	Accessories	Remarks
0903264x828 Female connector 64-pole Size C	Lever press 0999 000 0114	Support plate 09 99 000 0150	
		Separating tool 09 99 000 0116	For ribbon cables
		Cutter 09 99 000 0179	
		Cutting mat 09 99 000 0180	

3.5 Ethernet interfaces

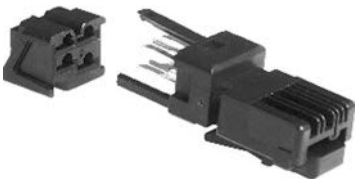


Figure XI-22: RJ45 data module

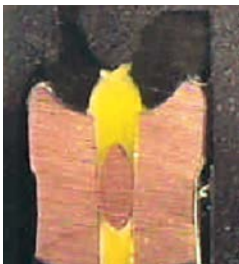


Figure XI-23: Contact with a solid wire core

HARTING RJ Industrial® Ethernet connectors

HARTING RJ Industrial® modular connectors are based on the standard RJ 45 mating profile. They have been specially designed for harsh industrial environments. Industrial applications require a connector that can be assembled in the field. Therefore, HARTING has consistently relied on its HARAX® rapid termination technology, which has proven itself in many industrial applications. Users require no special tools to connect the connectors. An RJ45 data module using IDC is at the core of these connectors.

No stripping of the wire or special tools are needed to establish a gas-tight connection that is resistant to vibration. The data module has four HARAX® IDC contacts that can establish secure contact with flexible industry-standard Category 5 ca-

ble with cross-sections from AWG 22 to AWG 24, as well as solid cable with cross-sections from AWG 22 to AWG 23.

HARTING has developed an entire line of connectors for this data module which meet all industrial application requirements. Solutions are available with IP20 and IP65/67 protection, as well as for various locking lever designs (snap-in, PushPull, and Han® 3 A).

The RJ45 connectors have the following technical characteristics:

Transmission characteristics according to Category 5 ISO/IEC 11801:2002 and EN 50173-1	
Mating geometry:	RJ45 according to IEC 60603-7
Wire diameter specifications:	AWG 22 – 24 flexible (stranded) AWG 22 – 23 solid
Wire insulation:	max. 1.6 mm Ø

Table XI-14: Overview of HARTING RJ Industrial® Cat. 5/Cat. 6/6_A connectors

Part number	Description	Remarks	Product photo
09 45 151 1110 09 45 151 1120 / ...1121	HARTING RJ Industrial® IP20 Data, 4 poles	Cable Ø 4.5 ... 9 mm	
09 45 151 1140 / ...41 /...42	HARTING RJ Industrial® MultiFeature IP20 Data, 4 poles	Cable Ø 4.5 ... 9 mm	
09 45 145 1106 09 45 195 1100	HARTING PushPull, V 4 4-pole (metal and plastic)	Plastic: 4.5 ... 10 mm Metal: 4.9 mm ... 8.6 mm	
09 45 151 1560 /...61	HARTING RJ Industrial® 10G, IP20, Cat. 6, 8 poles (straight & angled)	Cable Ø 4.5 ... 9 mm	
09 45 151 1570 09 45 151 1571 09 45 151 1572	HARTING RJ Industrial® MultiFeature IP20 RJ45 plug, Cat. 6 _A , 8 poles (straight & angled)	Cable Ø 4.5 ... 9 mm	
2082 101 0020 2082 101 0021 2082 101 0022	preLink RJ45 plug, IP20 Cat. 6 _A	Cable Ø 5 ... 9 mm	
09 45 145 1561 09 45 195 1560	HARTING PushPull V 4 RJ45 10G, 8 poles, Cat. 6, IP65 / 67 (metal & plastic)	Cable Ø 4.5 ... 10 mm	
09 35 225 0401 09 35 225 0402 09 35 225 0403 09 35 225 0421	Han® PushPull V 14 RJ45 10G, 8 poles, Cat. 6, IP65 / 67 (metal & plastic) (straight & angled)	Cable Ø 6.5 ... 9.5 mm	
09 35 220 0401 09 35 220 0402	Han® PushPull V 14 RJ45 MultiFeature, 8 poles, Cat. 6 _A , IP65 / 67 (straight & angled)	Cable Ø 6.5 ... 9.5 mm	
2082 104 0001 2082 204 0001	Han® PushPull V 14 preLink RJ45 connector 8 poles Cat. 6 _A , IP65 / 67 (metal & plastic)	Cable Ø 5 ... 9.5 mm	
09 45 400 1100	Han-Modular® RJ45 insert 4 poles, Cat. 5	Cable Ø 4 - 8 mm	
09 45 115 1560 09 45 125 1560	Han 3 A® RJ45 10G 8 poles, Cat. 6, IP65 / 67 (metal & plastic)	Cable Ø 5 ... 9 mm	
09 45 125 1760 09 45 115 1760	Han 3 A® RJ45 10G Hybrid 8 poles, Cat. 6 (metal & plastic)	Cable Ø: 6 ... 12 mm Wire Ø for the power supply: 4 x 1.5 mm ² (flexible/stranded)	
09 45 400 1560	Han-Modular® RJ45 10G insert, 8 poles, Cat. 6	Cable diameter 4 ... 8 mm	

Assembly instructions HARTING RJ Industrial® Ethernet connectors Cat. 5

The assembly of the data module is identical for all variants.

Table XI-15: Contact assignments according to the PROFINet® directive

Signal	Function	Wire colour	Contact no. RJ45
TD +	Transmission Data +	Yellow	1
TD -	Transmission Data -	Orange	2
RD +	Receiver Data +	White	3
RD -	Receiver Data -	Blue	6

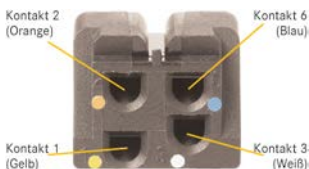
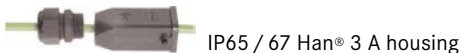


Figure XI-17: Rear view of data module

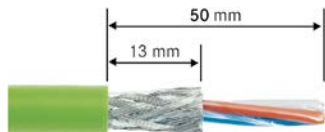
XI

Assembly steps

1. Push the cable gland and housing over the cable insulating sheath.



2. Strip 24 mm from the screening braid and 13 mm from the shielding braid.



3. Prepare the wires for insertion into the splice element according to the colour coding.



4. Fully insert the wires into the splice element until flush with the end.



5. Engage the splice element with the RJ 45 data module.



6. Insert the data module and the splice element into the IDC assembly tool provided.

XI



7. Squeeze together the data module and IDC assembly tool to create the IDC connection.



8. Remove the assembled data module from the IDC assembly tool.



9. Put on the upper shielding shell and press it over the cable screen.



10. Add the lower shielding shell; snap it together with the upper metal shield until it engages with an audible click.



11. IP20 Data and HARTING PushPull: Push the housing over the assembled data module until it engages with an audible click.

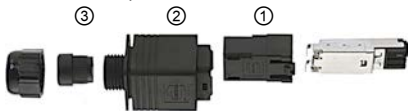


IP20 Data



HARTING PushPull

12. Han® PushPull: Put the HARTING RJ Industrial® insert ① in the RJ45 holder ②, then push back into the housing ③ (pay attention to the symbols!) – and snap in.



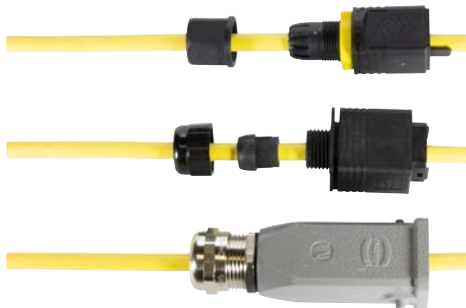
13. IP65 / 67 Han® 3 A RJ45: Place the data module in the adapter and push into the housing. Secure the adapter using the sealed screw.



14. Tighten the cable clamp.

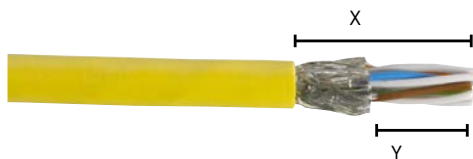
3.6 Assembly instructions for HARTING RJ Industrial® 10G IP65 / 67

1. Push the cable gland and housing over the cable insulating sheath.

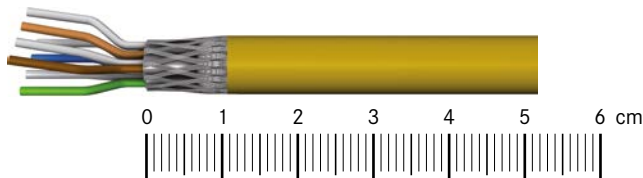


2. Remove the cable sheath over a length X of 24 – 26 mm and the shielding braid over a length Y of 14 – 16 mm.

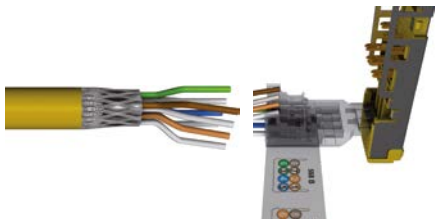
XI



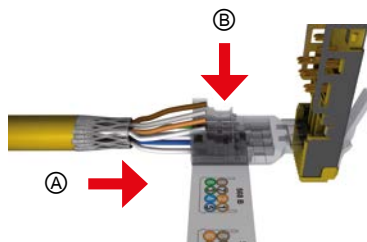
3. To guarantee simple assembly, check the stripping lengths from the following drawing at a 1:1 scale.



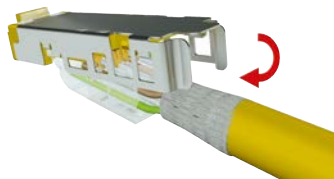
4. Sort the cables into their correct positions according to the selected colour coding before placing them into the cable manager.



5. Place the lower four wire cores according to the selected colour coding into the cable manager. Then place the upper four cables into the cable manager and press them in gently with your thumb. Use a small side cutter to cut the upper four wires to the correct length.



6. Close the cable manager. It closes with an audible click.



7. Snap the shielding shell together. It closes with an audible click.



8. Push the connector housing over the assembled data module (place the data module in the RJ 45 holder, if required) until it snaps in with an audible click (or secure it with the sealed screw).

► When pulling back, observe the symbols on the connector. Then tighten the cable clamp.

XI



Contact assignments

Contact number	Function/ Signal	Wire colour		
		TIA / EIA 568 A	TIA / EIA 568 B	Indus- trial
1	T3	green / white	orange / white	yellow
2	R3	green	orange	orange
3	T2	orange / white	green / white	white
4	R1	blue	blue	-
5	T1	blue / white	blue / white	-
6	R2	orange	green	blue
7	T4	brown / white	brown / white	-
8	R4	brown	brown	-

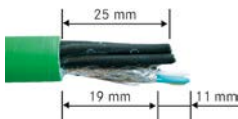
Assembly instructions for HARTING RJ Industrial® Hybrid

1. Plastic housing: Remove the two collars from the universal sealing ring in order to fit it onto the hybrid cable. Push the cable gland, pressure screw, universal sealing ring and housing over the cable sheath.



XI

2. Metal housing: Guide the cable clamp and housing over the hybrid cable.
3. Strip the cable sheath and screening braid to the proper length (for power wires to 25 mm; screening braid to 19 mm; for data wires to 11 mm, total of 30 mm).



4. Prepare the wires for insertion into the splice element according to the colour coding.



5. Fully insert the data wires into the splice element until flush with the end.



6. Put the splice element onto the RJ45 data module and snap it in.



7. Insert the data module and the splice element into the IDC assembly tool provided.



XI

8. Squeeze together the data module and IDC assembly tool to create the IDC connection.



9. Remove the assembled data module from the IDC assembly tool.



- Put on the upper shielding shell and press it over the cable screen. Add the lower shielding shell; snap it together with the upper shield until it engages with an audible click.



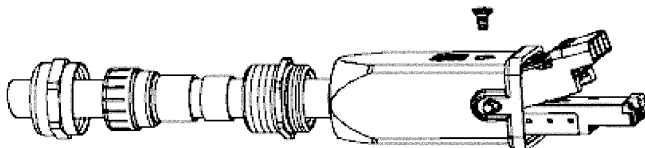
- Prepare the power wires and insert them all way into the hinge element of the insert.



- Press the individual hinge elements together with the integrated IDC contact. We recommend using a small slotted screw driver (max. 3.5 mm) as a lever.






- Metal housing:** Push the housing over the assembled data module and insert. Secure the insert using the housing's locking screw. Tighten this screw using 0.5 Nm torque.



- Tighten the cable clamp. We recommend using an open-ring spanner wrench with a spanner width (A/F) of 21 mm.

Industrial outlet Cat. 6

Table XI-18: Overview of Industrial outlets Cat. 6

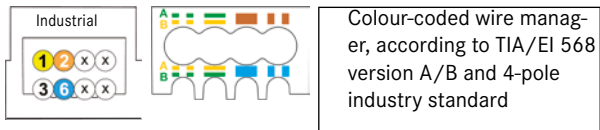
Part number	Description	Technical characteristics	Product photo
0945 851 0000 0945 851 0001 0945 545 1563 0945 545 1564	DIN rail outlet RJ45, IP20	Transmission properties: Category 6/Class E _A up to 500 MHz according to ISO/ IEC 11801:2002, EN 50 173-1 Termination technique: IDC Wire diameter: AWG 24-22 / 27-26	
09 45 845 1562 09 45 845 1563	HARTING PushPull Outlet RJ45, black/ white	Transmission properties: Category 6 according to ISO/IEC 11801:2002 or EN 50173:2002 Wire termination technique IDC Wire diameter: AWG 24 – 22 Solid and stranded Diameter of wire insulation: max. 1.7 mm Diameter of cable sheath: 6 – 9 mm	
0945 815 1560 2082 102 0101	Han® 3 A Metal outlet RJ45	Transmission properties: Category 6A according to ISO/IEC 11801:2002 For Class E transmission paths Termination technique: IDC, category 6 Wire diameter: AWG 24 – 22 Solid and stranded Diameter of cable sheath: 6 – 9 mm	

Assembly instructions for HARTING RJ Industrial® RJ45

1. Remove the cable sheath and peel back the screening braid over the cable sheath. Remove the wire shielding in pairs. Untwist the pair of data wires. Then position them properly according to the wiring label/sticker.



- 2a. Wiring for the 8-pole modules 09 45 545 1561 / ...1562



- 2b. Wiring for the 4-pole modules 09 45 545 1120



3. Insert the wires in the wire manager according to the wiring label and your desired wire assignments.



XI

4. Cut the individual wires flush with the end of the wire manager.



5. Press the wire manager and cable into the HARTING RJ Industrial® RJ45 module.



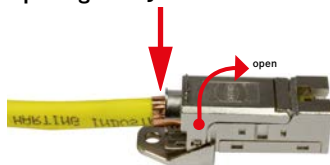
6. Close the HARTING RJ Industrial RJ45 module. An assembly tool may also be used.



7. Secure the cable using a cable tie. Cut off any excess screening braid.



Opening the RJ45 module



- Use release tool 20 82 000 9916 to open the module.
- Use the release tool as shown. Push in until the module opens.

XI

Technical characteristics

Transmission properties ac. to Cat. 6A ISO/IEC 11801:2002 and EN 50173-1

Degree of protection:	IP20
Mating geometry:	RJ45 socket, acc. to IEC 60603-7
Mating cycles:	> 750
Termination technique:	IDC rapid termination
Operating temperature:	-40 °C ... +70 °C
Wire cross-sections solid/stranded:	

09 45 545 1561: AWG 27 – 24

09 45 545 1120 / 1562: AWG 24–22

Max. wire diameter:

09 45 545 1561: 1.2 mm









09 45 545 1120 / ...1562:

1.7 mm /...5 – 9 mm

3.7 preLink® RJ45/M12 connectors and sockets

The preLink® cabling system features excellent speed, reliability and versatility. The modular system solution enables you to implement various Ethernet cabling. The product range includes interchangeable mating faces, such as RJ45, M12, D- and X-coded. This portfolio also encompasses solutions for different protection classes (such as IP20 or IP65/67) as well as device interfaces, junction boxes and a PCB solution. Ready-to-use system cables – with pre-assembled termination modules – supplement the portfolio. They enable you to terminate wires in seconds.

Table XI-19: Overview of the preLink® portfolio

<p>RJ45</p> 	<p>M12 D-coded</p> 	<p>RJ45 socket HIFF format</p> 	<p>Extender</p> 
<p>Han® PushPull V14 preLink® RJ45</p> 	<p>M12, X-coded</p> 	<p>RJ 45 Jack Keystone</p> 	<p>PCB socket</p> 

XI

The preLink® system consists of two basic components:

- ① Terminal module: The cable is connected using the preLink® terminal module.
- ② preLink® component: Connector, coupling, PCB socket ...

After the preLink® terminal module is mounted, it can fit into any preLink® component. They have identical holding fixtures, so that you can insert, remove or exchange the interfaces quickly and easily. Separate installations are also possible for this reason.

preLink® assembly principle

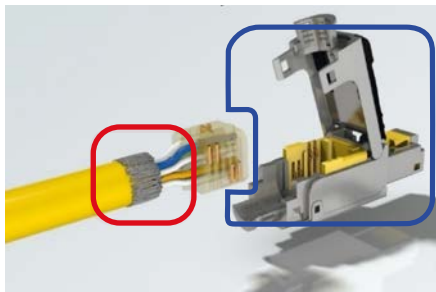
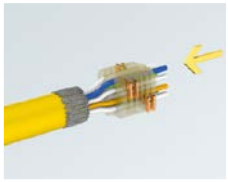

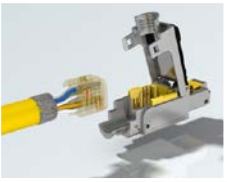


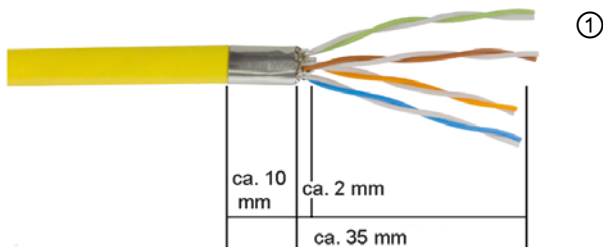
Figure XI-20:
preLink® terminal module,
RJ 45 mating face

Every preLink® assembly process consists of the following three steps.

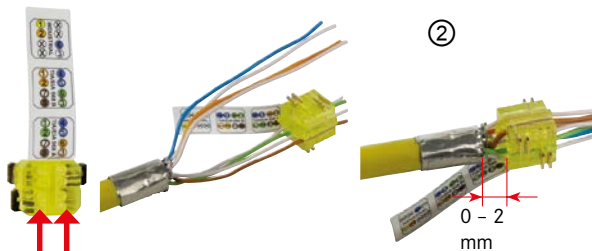
1	2	3
		
<p>1. Cable preparation and insertion of the individual wire cores according to the wiring diagram used for the preLink® terminal module.</p>	<p>2. Using preLink® pliers, the IDC contacts are crimped in precisely and properly, thus connecting the cores. This simultaneously cuts off the core ends in the same step.</p>	<p>3. The preassembled preLink® terminal module is simply snapped onto a variety of preLink mating faces – and it's ready!</p>

Assembly instructions for RJ45 connectors

1. Remove the cable sheath. Fold back the shielding braid over the cable sheath and remove the shielding foil in pairs. The copper foil can optionally be used to secure the cable braid.



2. Untwist the data pairs. Arrange them by colour code and insert into the terminal module (refer to the label/imprint).



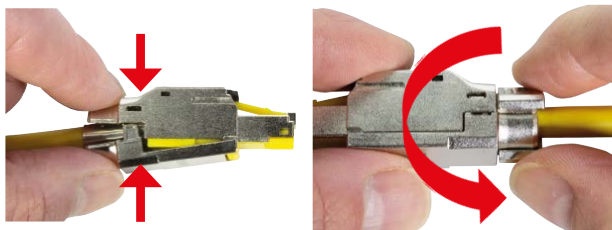
3. Insert the preLink® terminal module into the preLink® assembly pliers as far as it will go. Close the pliers completely (⇒ press in the insulation displacement contacts + shorten the wire core ends).



4. Insert the terminal module into the connector.

5. Press the connector together and attach the cable gland (\Rightarrow 1/4 turn).

⑤



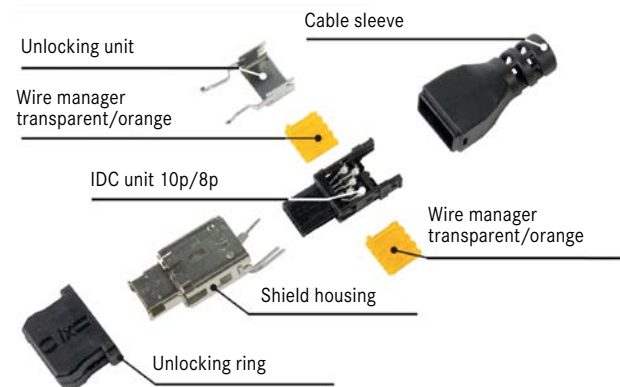
3.8 HARTING ix Industrial®

The ix Industrial is suitable for Industrial Ethernet type A (also suited for type C in the future), signals and serial BUS systems (type B). In addition to soldering, various insulation displacement contacts from AWG 28 to 22 are available as wire termination techniques. Cables can be connected easily thanks to the cable manager and the miniature insulation displacement contacts. A reliable contact is ensured when using the ix Industrial® assembly pliers.

Assembly manual

Assembly of the ix Industrial® (here, the Industrial® IP20 PushPull as an example):

XI



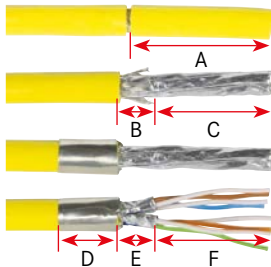
ix Industrial	10/100 Mbit/s	1 / 10 Gbit/s	TIA		PROF- INET
			568A	568 B	
1	TX+	BI_DA+	White/Green	White/Orange	Yellow
2	TX-	BI_DA-	Green	Orange	Orange
3	N.C.	N.C.	N.C.	N.C.	N.C.
4	N.C.	BI_DC+	Blue	Blue	N.C.
5	N.C.	BI_DC-	White/Blue	White/Blue	N.C.
6	RX+	BI_DB+	White/Orange	White/Green	White
7	RX-	BI_DB-	Orange	Green	Blue
8	N.C.	N.C.	N.C.	N.C.	N.C.
9	N.C.	BI_DD+	White/Brown	White/Brown	N.C.
10	N.C.	BI_DD-	Brown	Brown	N.C.

1. Preparing the cable

- a) Push the cable sleeve over the cable.

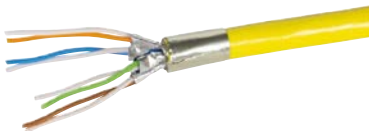


- b) Strip the cable and prepare the shielding. Secure the cable braid with the copper foil.



A	approx. 30 mm
B	5 mm
C	approx. 25 mm
D	5 mm
E	5 mm
F	approx. 25 mm

- c) Arrange the individual wire cores in two rows to match your application and your required wiring.

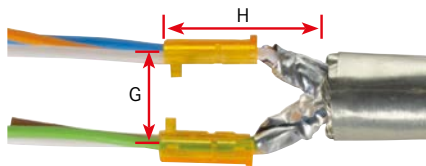


- d) Feed the individual wire cores into the wire manager according to the wiring diagram. If available, guide the wire manager up to the prepared shielding foil. For the TIA 568 A and TIA 568 B (both type A), also refer to the following tip:



- e) Position the wire managers according to the following illustration.

- Distance between the wire managers: $G = 8-9$ mm.
- Distance from the edge of the wire manager to the cable sheath: $H = 10-11$ mm.



- f) Disconnect the single wire cores after they are correctly positioned at the edge of the wire manager.

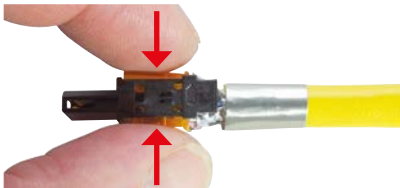


2. Inserting the wire managers into the IDC unit

- a) Position the two wire managers in the correct arrangement above the IDC unit.



- b) Use your fingers to press the positioned wire manager temporarily into the IDC unit.
- ▶ Make sure that the wire cores do not slip out of the wire manager as they are being pressed in and that the wire managers do not come loose again directly after being released.



- c) Check the correct position of the wire cores and the insulation displacement contacts. The wire cores must be above the insulation displacement contacts. Ideally, the cores should extend to the end of the wire managers.



IDC – Position of the insulation displacement contact

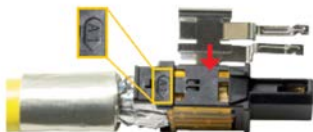
3. Contact the wire cores using the ix Industrial® assembly pliers

Insert the IDC unit with the temporarily attached wire managers all the way into the assembly pliers. Close the assembly pliers completely and remove the connected IDC unit from the pliers (⇒ refer to picture on next page).



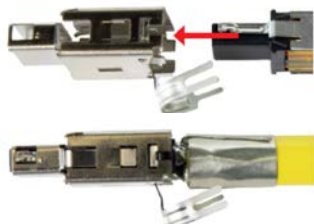
4. Assembling the shielding shell

a) Press the unlocking unit onto the IDC unit as shown.



XI

b) Press the IDC unit (along with the unlocking unit) into the shielding housing until it engages with an audible click.



c) Insert the assembled units all the way into the assembly pliers. Check that the cable crimp and the cable are correctly positioned. Crimp the cable by closing the ix Industrial® assembly pliers.



5. Assembling the protective hood

- a) Push the cable sleeve over the plug element until it locks into place.



- b) Push the unlocking ring over the plug element until it locks into place.



4. Piercing termination technique

4.1 Piercing termination overview

Standards

The following standard applies to the piercing termination technique:

- EN/IEC 60352-6

HARTING RJ Industrial® Gigalink connector Cat. 6A

Like the HARTING RJ Industrial® Cat. 5, the HARTING RJ Industrial® Gigalink connectors are based on the standard RJ45 mating profile. However, the piercing technique is used for the four-pair Gigalink variants.

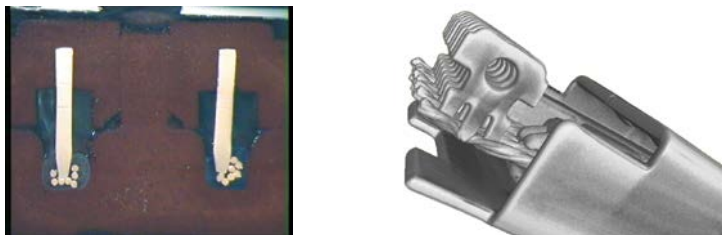


Figure XI-21: Micro-section of piercing termination technique

XI




HARTING has developed an entire line of connectors for the Cat. 6A Gigalink data module which meet all industrial application requirements. Solutions are available for IP20 and IP65/67 protection, as well as the standard, PushPull and locking levers.

The HARTING RJ Industrial® Gigalink Cat. 6A connectors satisfy the stricter requirements of Category 6A according to TIA/EIA 568 B.2-1:2002-06, EN 50173-1:2002 and ISO/IEC 11801:2002-09.

The RJ45 connectors meet the following technical characteristics:

Mating geometry	RJ45 according to IEC 60603-7
Diameter of individual wires	0.8 – 1.05 mm
Wire cross-section	AWG 28 – 24 flexible (stranded)

Table XI-19: Overview of HARTING RJ Industrial® Gigalink connectors Cat. 6A

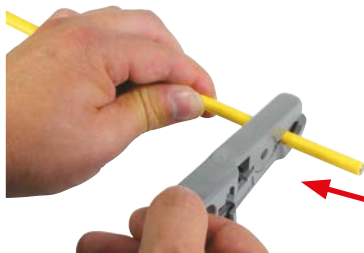
Part number	Description	Remarks	Product photo
09 45 151 1520	HARTING RJ Industrial® Gigalink Cat. 6A IP20, 8 poles	Cable diameter 4.5 ... 9 mm	
09 45 145 1521	HARTING PushPull connector set RJ45, 8 poles	Cable diameter 4.5 ... 10 mm	
09 45 1x5 1520	Han® 3 A connector set RJ45, 8 poles	Cable diameter 5 ... 9 mm	

4.2 Assembly instructions HARTING RJ Industrial® Gigalink Cat. 6A IP20

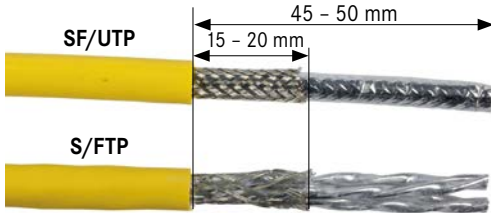
1. Push the cable clamp and housing over the cable.



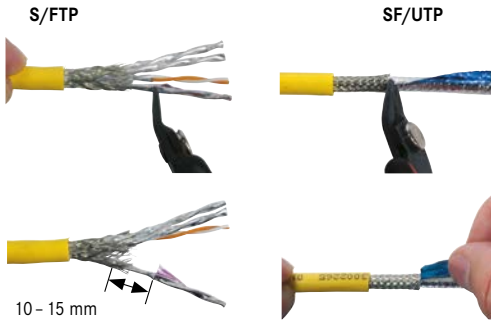
2. Strip the cable sheath and shielding braid (lengths ⇒ Figure on next page).



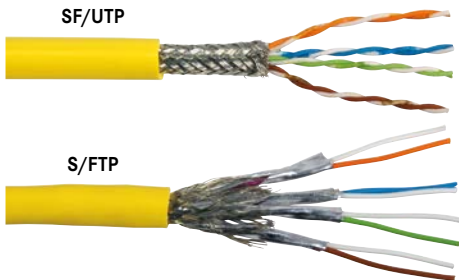
Tool
09 45 800 0002



3. Cut into and remove the screen foil.



4. Unwind the cable pairs and bend to the correct position.



5. Bend the wires and insert up to the shielding into the cable manager. The shielding foil for the wire pairs of S/FTP cables must reach to the die-cast zinc wire manager.

SF/UTP



S/FTP

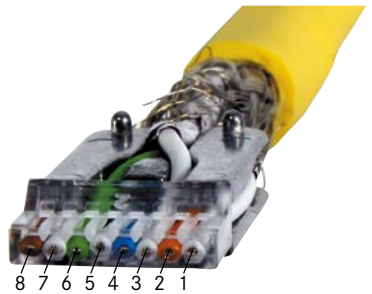


6. Cut off the protruding ends of the wires so that no short circuits are possible. No more than 0.3 mm of excess wire is permitted.



EIA / TIA 568B

7. Insert the cable with the wire manager all the way into the RJ45 data module.



XI



8. Put on the upper shielding shell and press it over the cable screen.



9. Press the contacts into the RJ45 data module with the HARTING RJ Industrial® assembly tool (part no. 09 45 800 0520). Ensure that the data module is pushed into the tool until it stops.



10. Add the lower shielding shell; snap it together with the upper shielding shell until it engages with an audible click.



11. Push the housing over the assembled data module until it snaps in with an audible click.



- XI 12. Tighten the cable clamp.



Contact assignments

Contact	EIA / TIA 568 A	TIA / EIA 568 B
1	green / white	orange / white
2	green	orange
3	orange / white	green / white
4	blue	blue
5	blue / white	blue / white
6	orange	green
7	brown / white	brown / white
8	brown	brown

XII. Press-in termination

Table of contents

1. Introduction	202
2. Definition of press-in technology	202
3. Recommended hole layout on the circuit board.....	203
4. Press-in process	205
5. Press-in tools	208
6. Manual lever and pneumatic presses.....	210
7. Overview of HARTING connectors with press-in technology	212
8. Requirements for press-in technology.....	213
9. HARTING presses.....	213
10. Conclusion	214

1. Introduction

A press-in (“press-fit”) connection is a solderless electrical connection made by inserting a press-in termination pin into a plated-*through hole* in a circuit board. A defining characteristic is that the press-in pin has a greater cross-section (diagonal) than the hole in the circuit board that is being contacted. So there is pressure exerted on the board as the pin is inserted into the hole. The hole in the circuit board and the elastic press-in zone both absorb this deformation force.

From the start, HARTING has relied on an elastic press-in zone. We started with the “Sigma” press-in zone and now use the “needle eye”. It’s important for HARTING that the connections are simple and reliable to process. Our top priority is that the press-in force is absorbed by the insert and not by delicately constructed processing tools.

HARTING press-in connectors have been designed to be easily pressed in using a flat stamping die. This transmits the press-in force directly to the housing.

The press-in technology has become a well-recognized, widely used method for establishing solderless connections. This termination technique is easy to implement and is highly reliable.

2. Definition of press-in technology

According to IEC 60352-5 (2012-02):

The press-in connection is made by pressing elastic (deformable) or solid (rigid) pins into the plated-*through holes* of printed circuit boards. This creates a *gas-tight*, highly conductive contact between the contact’s press-in zone and the board’s hole or the printed conductive paths.

HARTING recommends the following hole layouts for different surfaces.

Table XII-1: Examples of hole dimensioning, with contact layer

Circuit board hole diameter		1 mm	0.6 mm
Hole Ø		1.15±0.025 mm	0.7±0.02 mm
Copper (Cu):		min. 25 µm	
Sn circuit board	Sn	max. 15 µm	max. 15 µm
	End hole Ø	0.94 – 1.09 mm	0.60 – 0.65 mm
Chem. Sn circuit board	Sn	min. 0.8 µm	min. 0.8 µm
	End hole Ø	1.00 – 1.10 mm	0.60 – 0.65 mm
Au / Ni circuit board	Ni	3 – 7 µm	3 – 7 µm
	Au	0.05 – 0.12 µm	0.05 – 0.12 µm
	End hole Ø	1.00 – 1.10 mm	0.60 – 0.65 mm
Ag circuit board	Ag	0.1 – 0.3 µm	0.1 – 0.3 µm
	End hole Ø	1.00 – 1.10 mm	0.60 – 0.65 mm
OSP Cu circuit board	End hole Ø	1.00 – 1.10 mm	0.60 – 0.65 mm
Board thickness: ≥ 1.6 mm		≥ 1.6 mm	≥ 1.4 mm

Table XII-2: Connectors – DIN 41 612 – har-bus® 64, IEC 61 076-4-100 – Mini Coax, DIN SEK, har-bus® HM, D-Sub

A	Board thickness	min. 1.4 mm
B	Diameter of end hole	0.55 ±0.05 mm
C	Hole	0.64 ±0.01 mm
D	Copper	min. 25 µm
E	Surface	- min. 0.8 µm chem. Sn - 0.05 – 0.12 µm Au over 3 – 7 µm Ni
F	Rest ring	min. 0.15 mm

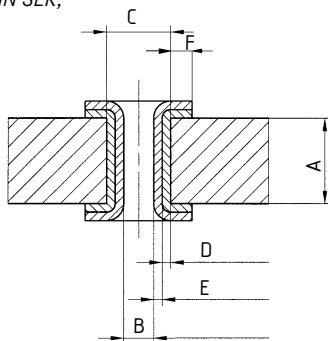


Figure XII-2: Schematic view of the circuit board's hole layout, 6 mm hole

4. Press-in process

The press-in process for connectors involves adapting the terminating pin to the circuit board's contact. Rather than simply pressing the contact in by hand, a hand-lever press or automatic press is used for this process. This ensures the required precision and repeatability. The press-in force is absorbed by the insert. When processing circuit boards with different physical characteristics, it is very important that the mechanical characteristics of the press-in zone have been optimally configured for the circuit board holes.

Three phases describe the connector's press-in process. This process involves mechanical and metallurgical influences.

Phase 1: Centring and placement of the terminating pin

It is important that the connector is properly centred in order to avoid damaging the circuit board or terminating pins. Centring inaccuracies are negligible when flat stamping dies are being used.

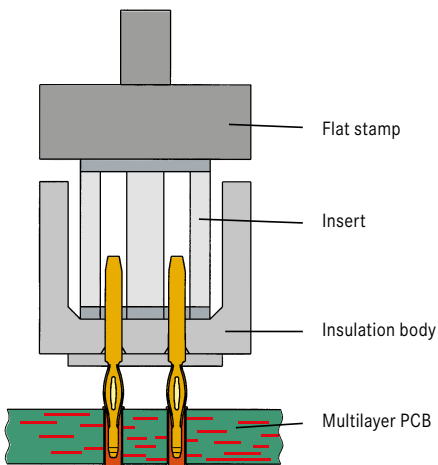


Figure XII-3: Phase 1

Phase 2: Pressing in the pins

During the pressing in, the shear stress is continuously converted to compressive stress. The resulting rubbing motion cleans the contacting edges from any insulating coating. This ensures a *gas-tight* connection.

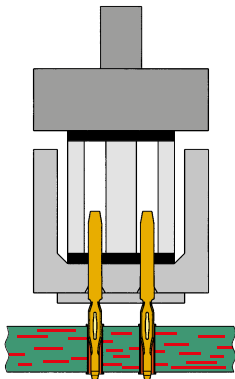


Figure XII-4: Phase 2

Phase 3: Reaching the end position

The press-in process must be immediately stopped when it reaches the end position. Therefore, excess pressure cannot build up.

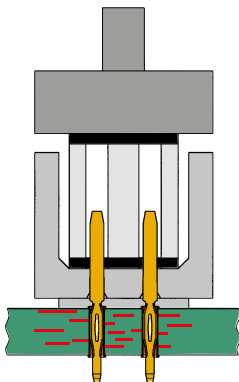
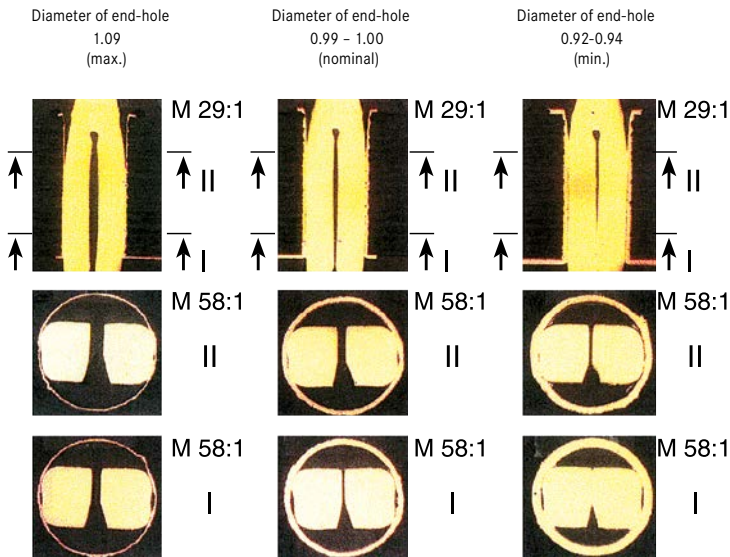


Figure XII-5: Phase 3

The press-in process is now completed.

HARTING's *har*-press® press-in zone

The *har*-press® press-in zone is based on the established needle-eye technology. The special shape enables it to compensate when certain tolerance levels are exceeded for the surfaces (e.g. when there is superfluous tin plating). This ensures that a *gas-tight* electrical connection is created that is resistant to corrosion.



XII

Figure XII-6: Cross-sectional images of a 2.4 mm thick circuit board, varying hole diameters

5. Press-in tools

General

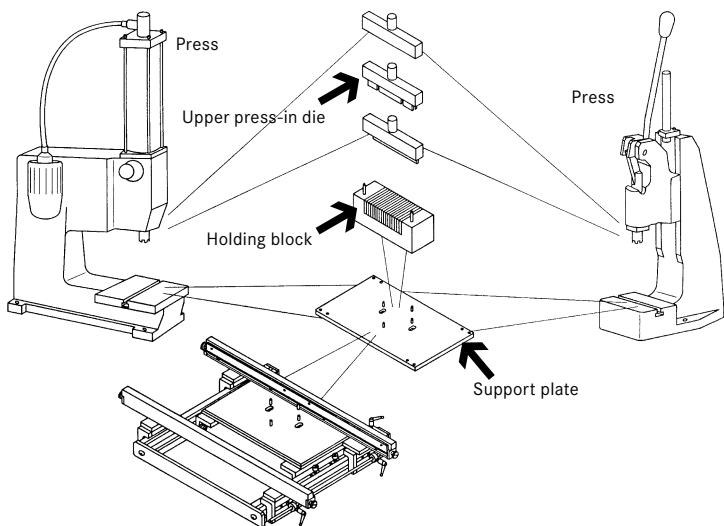
Hand-lever presses and semi-automatic presses are available for pressing in the connectors. The tool must ensure that the press-in force is transmitted via the insulating housing to the contacts. When working with the hand-lever press, a depth end-stop point (bottom dead centre) is defined so that the proper press-in depth is always ensured. Always make sure that the functional surfaces of the contact are not damaged. It is also important to ensure that there are no flaws or damage on the surface of the circuit board. Suitable equipment must be used to ensure that the circuit board is stabilised during the press-in process. This prevents it from being damaged by bending. The stabilisation mechanism must grip the board very close to the hole that the contact will be pressed in. An appropriate holder for the entire circuit board is the best way to ensure that the board does not bend during the press-in process.

There are modular tool systems on the market today which ensure that different connector versions and assembly layouts are processed properly.

Press-in tools from HARTING

HARTING's modular tool system can be used to make press-in connections with many different connectors. The tools provide a key advantage for a cost-effective workflow. The required basic module of the tool system are:

- Presses
- Press-in stamping dies
- Holding block
- Support plate

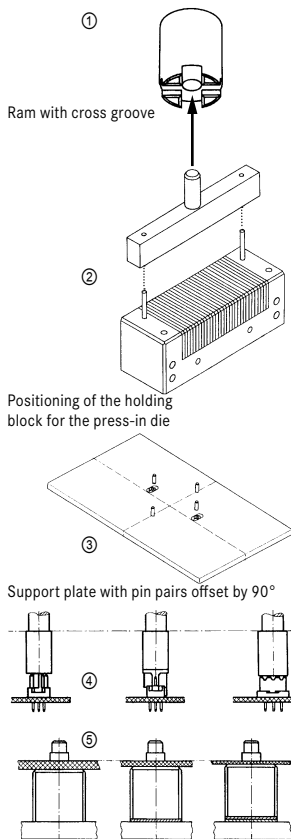


XII

Figure XII-6: Construction of HARTING's modular tool system

6. Manual lever and pneumatic presses

The working height of the press and the support plate must be adjusted when setting up the work place. Further information related to this are given in the instructions accompanying these modules. No further adjustments are required. The modules can be efficiently and reliably combined in various configurations to match the requirements of your application.



Different contacts pressed into PCBs

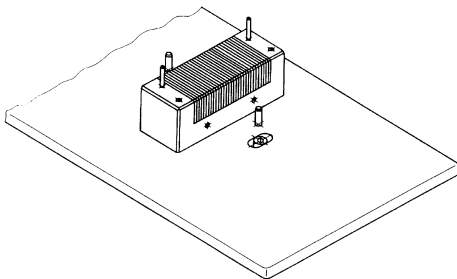
Height adjustment

Figures XII-7: Press-in tool at work

- ① The ram is equipped with a cross groove, which allows for the positioning of the press-in die at an angle of 0° or 90°. The cross groove passes the press-in force onto the press-in die.
- ② The connectors are pressed into the PCB at a position between the press-in die and the holding block. Using pin pairs, the holding block must be securely fixed onto the support plate. The support plate must be offset by 0° or 90°.
- ③ For fixing the holding block, the support plate is equipped with pins. In order to compensate for differences in PCB thickness, type-specific spacers can be inserted into the space between the holding block and the support plate.
- ④ There are different tools for different kinds of connectors. They are all designed to make sure that, when being used, the initial height settings of the manual lever press do not need to be changed.
- ⑤ Spacers for levelling differences in PCB thickness: By using spacers you can create a uniform starting position for the press-in dies of the manual lever press.

Holding block

The all-purpose holding block has a wide range of use. The holding block can be used with all connector sizes that use straight press-in connections in 2.54 mm pitch.



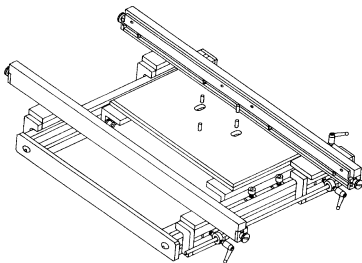
*Figure XII-8:
Holding block configured to
hold connectors*

Guide frame

The guide frame (screwed on the support plate) secures the position of the circuit board for the press-in die. A significantly higher processing speed is thus possible.

Both guide rails can be adjusted to match different board formats.

A spring-loaded support rail lifts the circuit board from the holding block after the press-in step. This prevents the circuit board or conductive paths from being damaged when the guide frame is shifted.



*Figure XII-9:
Guide frame that positions
the circuit board for the
press-in die*

Additional information about HARTING tools can be found in the corresponding catalogues (DIN 41612, interface, metric and device connectivity).

7. Overview of HARTING connectors with press-in technology

Table XII-3 lists the HARTING connectors with press-in technology. Specifications have been taken from up-to-date catalogue data.

Table XII-3: Overview of HARTING connectors with press-in technology

Specifications / series	Size	Pole count	Female/male	Standard
DIN 41612	B, 2B	32 + 64	Female	IEC 60 603-2
DIN 41612	C, 2C, 3C	30 - 96	Female	IEC 60 603-2
DIN 41612	M	78 + 2 60 + 4 42 + 6 24 + 8	Female	IEC 60 603-2
DIN 41612	M-flat	78 + 2 60 + 4 42 + 6 24 + 8	Female	IEC 60 603-2
DIN 41612	M inverse	6+10 24+8 42+6 60+4 78+2		IEC 60 603-2
DIN 41612	Q, 2Q	32 - 64	Male	IEC 60 603-2
DIN 41612	R, 2R	32 - 96	Male	IEC 60 603-2
DIN 41612	RM	96	Male	IEC 60 603-2
DIN 41612	E	48	Female	IEC 60 603-2
DIN 41612	F	32 - 48	Female	IEC 60 603-2
DIN 41612	H	15	Female	IEC 60 603-2
IEC 61 076-4-113	-	160	Female	
har-bus [®] HM	A, B, AB, C	55 - 175	Female/male	IEC 61 079-4-101
har-bus [®] HM	D, E, DE	176 - 250	Male	IEC 61 079-4-101
har-bus [®] HM	Monoblock	220 - 308	Female/male	IEC 61 079-4-101
Mini Coax	1 - 1.5 SU	2 - 14	Male/female	
DIN 41 652 CECC 75 301-802 IEC 60 807	Straight	9 - 25 9 - 50	Male Female (V-shaped)	
SEK	-	6 - 64	Male connectors	IEC 60 603-13
PICMG	Advanced TCA mTCA	170	Card Edge	

8. Requirements for press-in technology

The quality of a press-in connections depends on three components:

- The circuit board
- The component being connected
- The processing tool

DIN EN 60352-5 is referenced as the standard for “Requirements and quality testing for press-in connections”.

9. HARTING presses

In addition to our tools for processing press-in connectors, HARTING also offers presses. There are three types of presses:

- The hand-lever press
- The pneumatic press
- The CPM press-in machine

Additional information about these presses can be found in the corresponding catalogues (DIN 41612, interface, metric and device connectivity). The associated operating instructions contain more information about adjusting and assembling the presses.

Pneumatic press



- Easy to operate
- Maximum press-in force is adjustable
- Suitable for mid-sized batches



Hand-lever press

- Easy to install
- No electrical or pneumatic connection is required
- Suitable for producing prototypes and small batches

Figure XII-10: Harting's press-in tools and machines

10. Conclusion

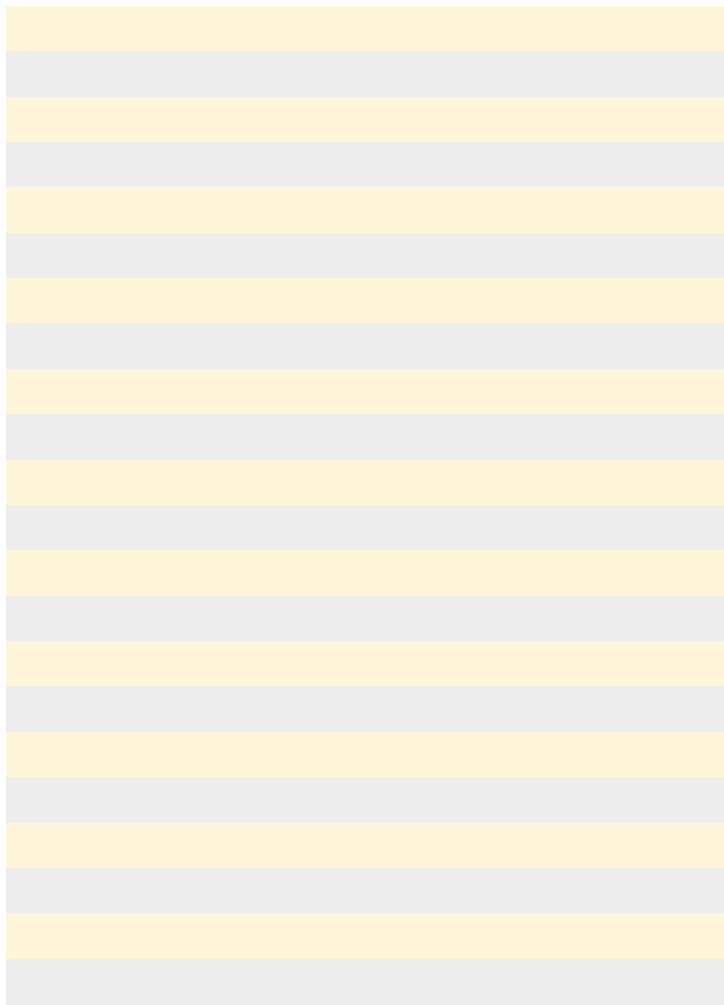
The following points are critical for achieving a reliable, stable press-in connection:

- The press-in contact, circuit board and press-in tools must all be harmonised to work together.
- The formation of any significant meniscus or residual tin must be avoided (tin chips on the circuit board can lead to device short circuits).
- Be sure not to tear or detach any conductive paths or copper collars during the press-in process. These could prevent the contact from properly contacting the conductive path.

When these points are followed, the benefits of press-in technology listed below are convincing:

- Temperature shocks caused by soldering and the associated risk of board failure are avoided.
- There is no need to subsequently clean the assembled circuit board.
- Additional wrap connections are possible using connectors with long terminating pins.
- An affordable and unrestricted processing method for selective gold plating of pins for backplane bus systems – soldering by hand is no longer necessary!

Notes



XII

XIII. Fibre optic termination

Table of contents

1. Introduction	218
2. Planning of optical transmission systems	219
2.1 Influencing factors	219
2.2 Calculation examples	221
3. Assembly of fibre optic connectors.....	223
3.1 F-SMA connector for 1 mm POF with 2.2 mm cable sheath	223
3.2 F-SMA connectors for 1 mm POF with 3.6 mm cable sheath.....	225
3.3 F-SMA connectors for 1 mm POF with 6 mm cable sheath.....	227
3.4 Quick-assembly connectors for 1 mm POF with 2.2 mm cable sheath	229
3.5 F-ST connectors for 1 mm POF with 2.2 mm cable sheath	230
3.6 FO cable end sleeve for 1 mm POF with 2.2 mm cable sheath	232
3.7 F-TNC connectors (female)	234
3.8 F-TNC connector (male)	236
3.9 F-ST connectors for glass fibre	238
3.10 SC contacts for glass fibre.....	240
3.11 LC contact for GI fibre and single-mode fibres.....	242
4. FO contacts	244
4.1 FO contacts for Han D [®] and Han DD [®] contact inserts	244
4.2 FO contacts for Han E [®] inserts.....	246
4.3 FO contacts for 1 mm POF in Han-Modular [®]	248
4.4 FO contacts for GI fibre in Han-Modular [®]	250
4.5 Han-Brid [®] FO contacts	252
5. Operating instructions of HARTING four-indent crimping tool for 1 mm POF contacts.....	253
6. Tool kit	256
6.1 POF assembly kit with optical measuring devices.....	256
6.2 FO measuring device kit	258
6.3 GI fibre assembly kit	259
7. Overview of assembly	262

1. Introduction

In addition to applications in remote connections for messages in the telecommunications sector, the importance of fibre optic technology is also increasing for applications in the industrial sector. In telecommunications, the aspects of

- high transmission capacity
- low cable attenuation
- no cross-talk

are essential for the application.

In the industrial sector, additional specific properties such as

- immunity to electro-magnetic influences
- galvanic isolation of transmitter and receiver
- small cable dimensions

have priority.

Messages are transmitted via fibre optics using light pulses. After coupling into one end of the fibre, the pulses are forwarded as a result of total reflection to the other end with low loss.

This is made possible due to the total reflection at the boundary layer core/sheath due to the different values of the optical *refractive index* n of the core and sheath material ($n_{\text{sheath}} < n_{\text{core}}$).

Three types of fibre optics can be distinguished:

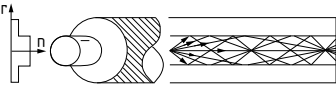
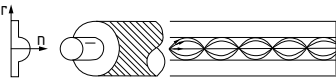
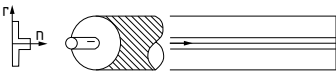
		Typical Dimensions Core/Cladding ϕ	Attenuation
Step index fibre HCS / POF		200/230 μm	5-8 dB/km
		980/1000 μm	0.2 dB/m
Graded index fibre GI fibre		50/125 μm	2.6 dB/km
		62,5/125 μm	3.2 dB/km
Single-mode fibre		9/125 μm	< 0.3 dB/km

Figure XIII-1: Path of the optical refractive index

The *single-mode fibre* is used primarily because of its low attenuation and large bandwidth for remote data transmission in the telecommunications sector. However, the *graded index fibres* and the *step index fibres* with their

large core diameters are the preferred transmission media in the industrial sector, as they are inexpensive and easy to use. The transmission distances range from several tens of meters to several kilometres.

Graded index fibres are usually joined with the connector. With *POF* (Polymer Optical Fibre) or *HCS* (*Hard Clad Silica*)¹⁾ fibres, crimping technology facilitates the assembly of connectors. With the HARTING quick assembly technique, *POF* cables can be mounted without any special tools.

HARTING FO systems are designed for *graded index fibres* (GI) with 50 and 62.5 μm core diameter, *single-mode fibres* with 9 μm and *step index fibres* with 200 μm (*HCS*[®]) and 1 mm (*POF*). The optical wavelengths used are 660 nm (*POF*), *HCS*[®], 850 nm (GI, *HCS*[®]) and 1300 nm (GI/*Single-Mode* = SM).

Footnote: ¹⁾ A registered trademark of SpecTran Corporation.

2. Planning of optical transmission systems

2.1 Influencing factors

For a reliable operation of a fibre optic transmission system, it is necessary that the transmitted optical signals reach the receiver with sufficient amplitude. The received power should be at least twice as large (+3 dB) as the limiting sensitivity of the receiver, so that sporadic errors in data transmission do not occur due to system-inherent noise. When planning the system, therefore, a power balance chart should be used to assess if these requirements are met. The influence variables listed below are of importance here.

Optical transmitter output power

The optical power generated by the LED is essentially dependent on the supplied current. The portion coupled into the fibre will also be greatly influenced by the core dimensions and the type of fibre used.

XIII

Typical power ranges available in the fibre core are:

- for optical fibres ($\lambda = 850 \text{ nm}$):

50 / 125 μm GI fibre:	80 μW
200 / 230 μm SI fibre:	250 μW
9 / 125 μm SM fibre:	20 μW
- for polymer fibre ($\lambda = 660 \text{ nm}$):

980 / 1000 μm :	600 μW
----------------------------	-------------------

Specific attenuation of the fibre

The specific attenuation depends on the operation wavelength and is expressed in dB/km.

Typical values

- for optical fibres ($\lambda = 850$ nm)
 - 50 / 125 μm *GI fibre*: --- 3 dB/km
 - 200 / 230 μm *HCS*: --- 5 dB/km
- for optical fibres ($\lambda = 1300$ nm)
 - 9 / 125 μm SM fibre --- 0.5 dB/km
- for polymer fibres ($\lambda = 660$ nm)
 - 980 / 1000 μm (PMMA): --- 0.2 dB/m

This portion typically provides the greatest contribution to total attenuation of the optical path.

Additional cable joints in the optical cable

Additional cable joints in the optical signal path (splices or connectors) further weaken the transmitted optical signal.

Typical values

- for splices: ≤ 0.3 dB
- for each connector pair: 0.8 dB to 0.5 dB (*GI fibre*)

The exact values depend on the type of fibre and the connectors used.

XIII Sensitivity of the optical receiver

Conventional DC-coupled optical receivers with Si diodes as receiving elements have the following typical limiting sensitivities:

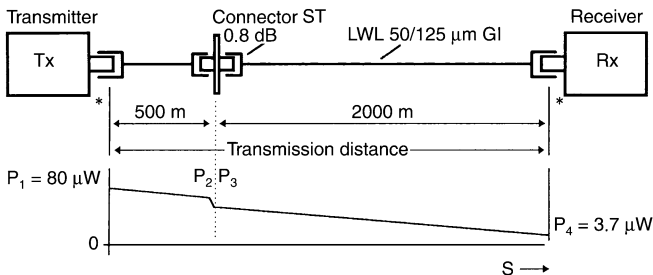
- $\leq 3 \mu\text{W}$ at 850 nm (fibre optic systems)
- $\leq 5 \mu\text{W}$ at 660 nm (polymer fibre systems)

Influence of temperature and aging of LED, temperature dependence of the cable attenuation

These factors should be considered in the power balance using a value of 2 dB as the “excess loss”, so that a total value of 5 dB must be used as the “system reserve”.

2.2 Calculation examples

a) Fibre optic system ($\lambda = 850 \text{ nm}$)



* Coupling attenuation at the transmitter/receiver are not considered separately, since they are already included in the output data for T_x and R_x .

Power balance

Transmitter:

$$P_1 = 80 \mu\text{W} = -11 \text{ dBm}$$

Power coupled into fibre core

$$\text{Fibre loss: } 2.5 \text{ km} \times 3 \text{ dB/km} = 7.5 \text{ dB}$$

$$\text{ST connector} = 0.8 \text{ dB}$$

$$\text{System reserve (3 dB + 2 dB)} = 5.0 \text{ dB}$$

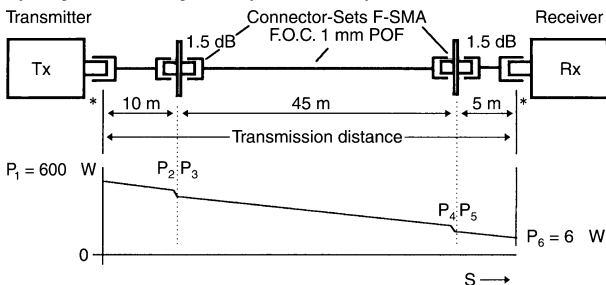
$$\text{Total system losses:} = \mathbf{13.3 \text{ dB}}$$

Receiver:

$$P_4 = -24.3 \text{ dBm} = 3.7 \mu\text{W}$$

Minimum value $\geq 3 \mu\text{W}$ is fulfilled.

b) Polymer fibre system ($\lambda = 660 \text{ nm}$)



Power balance

Transmitter:

- $P_1 = 600 \mu\text{W} = -2.2 \text{ dBm}$ in the power coupled fibre
- Fibre attenuation: $60 \text{ m} \times 0.2 \text{ dB/m} = 12.0 \text{ dB}$
 - F-SMA connector ($2 \times 1.5 \text{ dB}$) = 3.0 dB
 - System reserve ($3 \text{ dB} + 2 \text{ dB}$) = 5.0 dB
 - Total: 20.0 dB

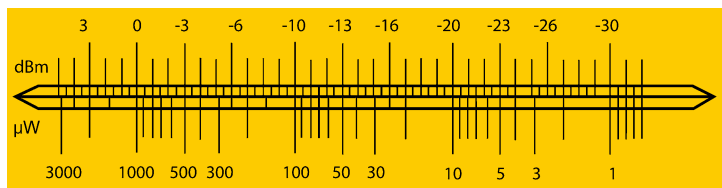
Receiver:

$$P_6 = -22.2 \text{ dBm} = 6.0 \mu\text{W}$$

Minimum value $\geq 5 \mu\text{W}$ is fulfilled.

If the additional splitting points in the optical were to be omitted (2 F-SMA connectors here), the resulting range in terms of distances would be larger.

Conversion scale



3. Assembly of fibre optic connectors

The following pages describe the assembly of the fibre optic connectors used at HARTING.

Caution!

It is absolutely essential to always wear appropriate protective clothing and goggles when working with open optical fibres.

3.1 F-SMA connector for 1 mm POF with 2.2 mm cable sheath

Part numbers:

20 10 001 1211 (with hexagon fitting nut)

20 10 001 1213 (with knurled fitting nut)

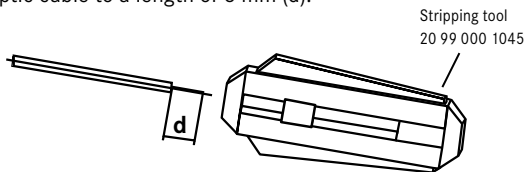


Figure VII-2: F-SMA connector for 1 mm POF

Assembly

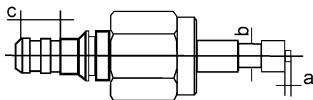
- Strip the fibre optic cable to a length of 8 mm (d).

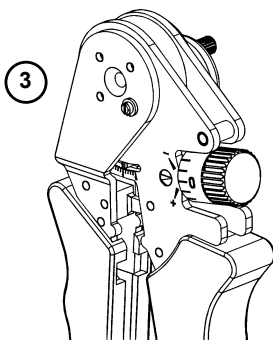
①



- Attach the connector to the cable. With the cable completely inserted, the fibre should protrude about 1 mm (a) out of the connector tip.

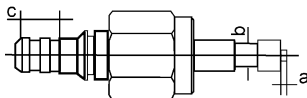
②



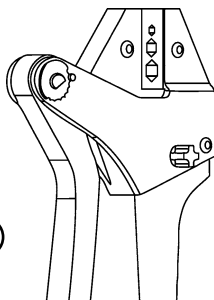


Four-indent crimping tool
for POF
20 99 000 1035

3. Use the four-indent crimping tool ③ to crimp the FO fibre in the designated area of the contact tip (b). Set the crimp die with crimping tool closed: \varnothing 2.0 mm locator setting 3 (refer to the operating instructions of the four-indent crimping tool).



4. Crimp the FO cable sheath with the wiring range of the contact to a length of 4 m (c), using the hexagonal crimping tool (AF 3, refer to ④).

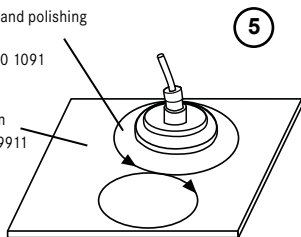


Hexagonal crimping
tool for POF
20 99 000 1033

5. Using the grinding and polishing block, polish the protruding fibre on a lapping film with grain size 1000 and a hard surface, e.g. glass plate. The contact face can be repolished with a polishing paper 9μ grit.

Grinding and polishing
block
20 99 000 1091

Lapping film
20 80 001 9911



6. Check the quality of the face with a microscope at 30x magnification.

3.2 F-SMA connectors for 1 mm POF with 3.6 mm cable sheath

Part numbers:

20 10 001 1241 (with hexagon nut)

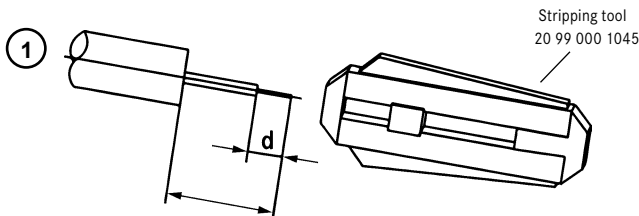
20 10 001 1243 (with knurled nut)



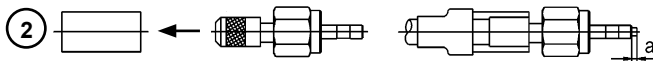
Figure VII-3: F-SMA for 3.6 mm SERCOS cable

Assembly

- Strip the FO cable to a length of 25 mm (l). The strain relief (Kevlar) is cut along the entire length. Strip the cable sheath of the fibre to a length of 8 mm (d).

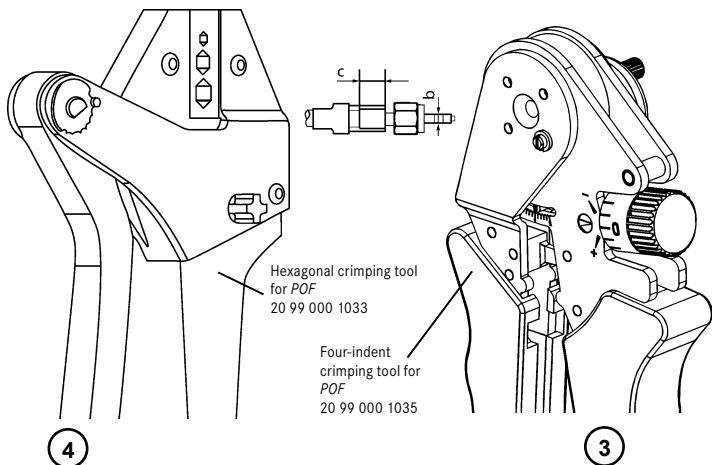


- Put on the bend protection and the crimp barrel on the cable. Push the connector with the cable side about 6 mm under the outer cable sheath. With the cable completely inserted, the fibre should protrude about 1 mm out of the connector tip (a).

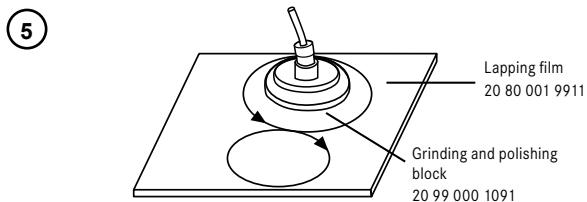


XIII

3. Use the four-indent crimping tool to crimp the FO fibre in the designated area of the contact tip (b). Set the crimp die with crimping tool closed: \varnothing 2.0 mm, locator setting 3 (refer to operating instructions of four-indent crimping tool).
4. Slide the crimp barrel over the strain relief and crimp the FO cable, using the hexagonal crimping tool (c) (AF 4.95 mm). Apply the crimping tool twice.



5. Using the grinding and polishing block, polish the protruding fibre on a lapping film with 1000 grit and a hard surface, e.g. glass plate. The contact face can be repolished with a polishing paper 9 μ grit.



6. Check the quality of the face with a microscope at 30x magnification.
7. Push the cable bend protector over the crimp barrel.

3.3 F-SMA connectors for 1 mm POF with 6 mm cable sheath

Part numbers:

20 10 001 1221 (with hexagon nut)

20 10 001 1223 (with knurled nut)

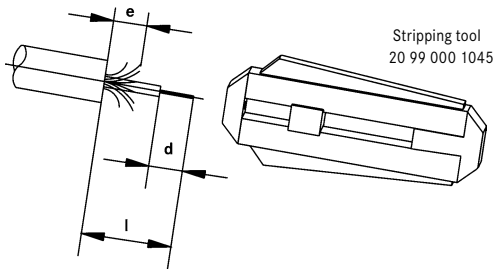


Figure VII-4: F-SMA for 6 mm SERCOS cable

Assembly

- Strip the FO cable to a length of 32 mm (l). The strain relief (Kevlar) is cut along 8 mm (e). Strip the cable sheath of the fibre to a length of 8 mm (d).

1



- Put on the bend protection and the crimp barrel on the cable. With the cable completely inserted, the fibre should protrude about 1 mm out of the connector tip (a).

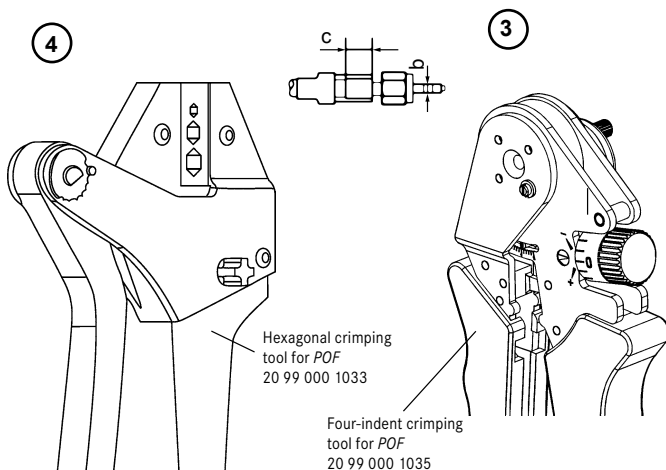
2



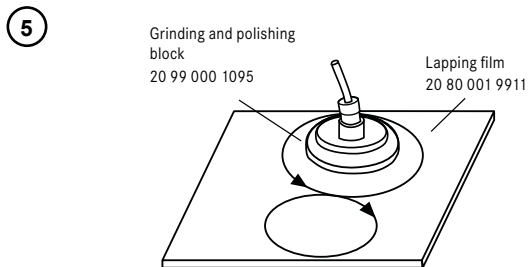
- Use the four-indent crimping tool to crimp the FO fibre in the designated area of the contact tip (b). Setting with crimping tool closed: \varnothing 2.0 mm.

XIII

4. Push the crimp barrel over the strain relief and crimp the FO cable using the hexagonal crimping tool (c) (AF 6.5 mm). Apply the crimping tool twice.



5. Using the grinding and polishing block, polish the protruding fibre on a lapping film with 1000 grit and a hard surface, e.g. glass plate. The contact face can be repolished with a polishing paper 9 μ grit.



6. Check the quality of the face with a microscope at 30x magnification.
7. Use a heat source to shrink the shrink tube over the crimping position.

3.4 Quick-assembly connectors for 1 mm POF with 2.2 mm cable sheath

Part numbers:

- 20 10 001 1212 F-SMA with hexagon nut
- 20 10 001 1215 F-SMA with knurled nut
- 20 10 001 1217 F-SMA with knurled nut and cable bend protector
- 20 10 001 2212 F-ST
- 20 10 001 5217 SC contact
- 20 10 001 5218 SC contact with bend protector

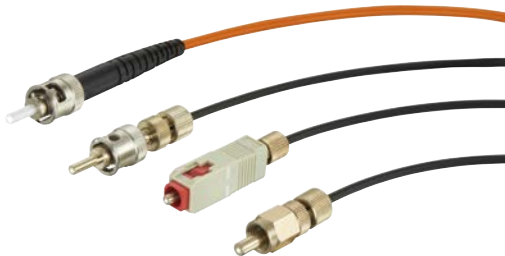
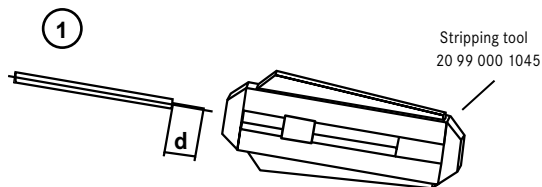


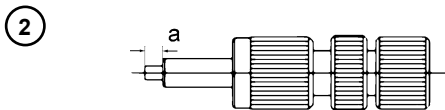
Figure VII-5: F-SMA and F-ST connectors, SC contact (2nd f.r.)

Assembly

1. Strip the FO cable to a length of 10 mm (d).

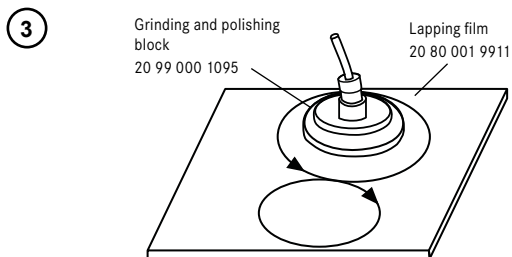


2. Position the connector on the cable. With the cable completely inserted, the fibre should protrude about 1 mm (a) out of the connector tip. Fix the cable by tightening the knurled nut.



XIII

3. Using the grinding and polishing block, polish the protruding fibre on a lapping film with 1000 grit and a hard surface, e.g. glass plate. The contact face can be repolished with a polishing paper 9 μ grit.



3.5 F-ST connectors for 1 mm POF with 2.2 mm cable sheath

Part number: 20 10 001 2211

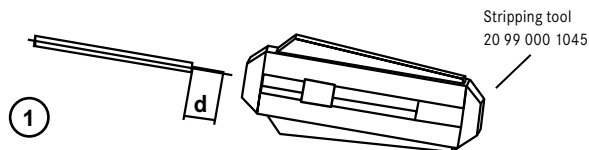


Figure XIII-7: F-ST connectors

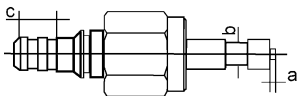
XIII

Assembly

1. Strip the FO cable to a length of 10 mm (d).

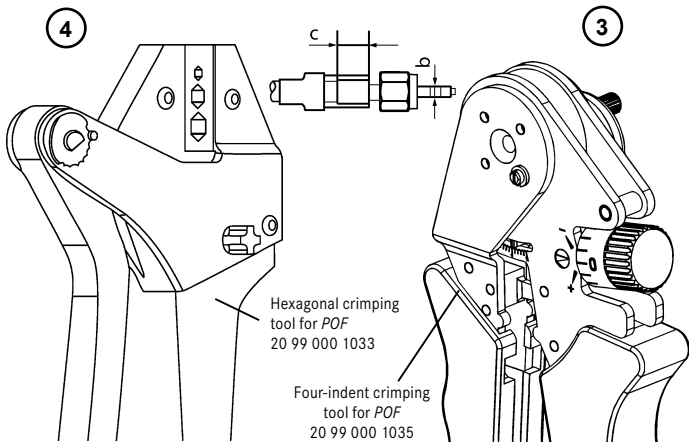


- Position the connector on the cable. With the cable completely inserted, the fibre should protrude about 1 mm (a) out of the connector tip. 2



- Use the four-indent crimping tool to crimp the FO fibre in the designated area of the contact tip (b). Set the crimp die with crimping tool closed: \varnothing 2.0 mm, locator setting 3 (refer to operating instructions of four-indent crimping tool).

- Crimp the FO cable sheath using the hexagonal crimping tool (AF 3 mm) with the wiring range of the contact to a length of 4 mm (c) .

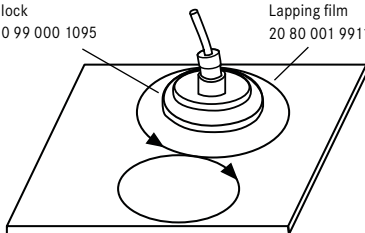


- Using the grinding and polishing block, polish the protruding fibre on a lapping film with 1000 grit and a hard surface, e.g. glass plate. The contact face can be repolished with a polishing paper 9 μ grit.

5

Grinding and polishing
block
20 99 000 1095

Lapping film
20 80 001 9911



6. Check the quality of the face with a microscope at 30x magnification.

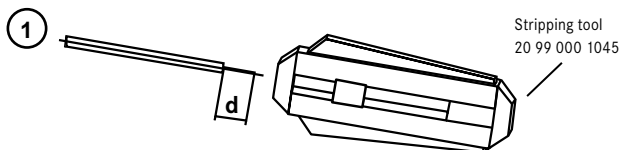
3.6 FO cable end sleeve for 1 mm POF with 2.2 mm cable sheath

Part number: 20 10 001 3232

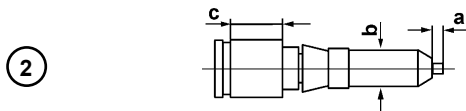


Assembly

1. Strip the cable to a length of 11 mm (d).

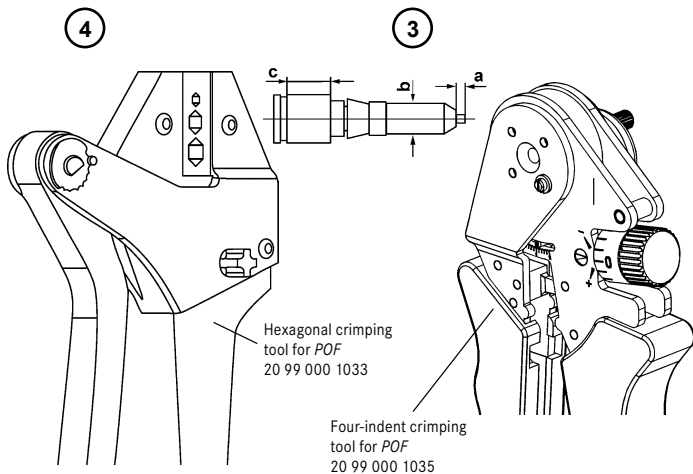


2. Position the contact on the cable. With the cable completely inserted, the fibre should protrude about 1 mm (a) out of the connector tip.

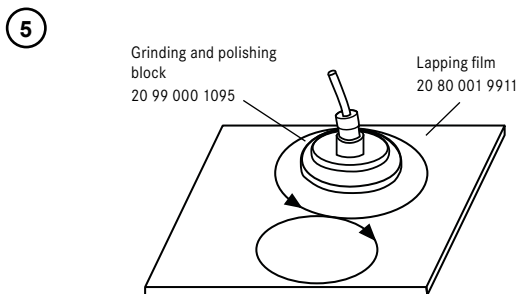


2

- Use the four-indent crimping tool to crimp the FO fibre in the designated area of the contact tip. Setting with crimping tool closed: \varnothing 1.8 mm (b).
- Crimp the FO cable sheath using the hexagonal crimping tool over a length of 3 mm (c) (AF 3 mm).



- Using the grinding and polishing block, polish the protruding fibre on a lapping film with 1000 grit and a hard surface, e.g. glass plate. The contact face can be repolished with a polishing paper 9μ grit.



- Check the quality of the face with a microscope at 30x magnification.

3.7 F-TNC connectors (female)

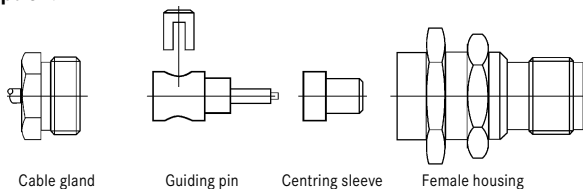
Part number: 20 10 001 6233

This connector is designed for 1 mm *POF* with 2.2 mm cable sheath.



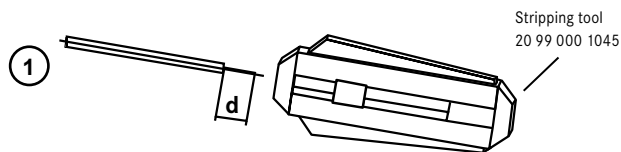
Figure XIII-9: F-TNC female

Description:

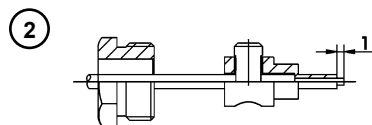


Assembly

- Strip the FO cable to a length of 7 mm (d).

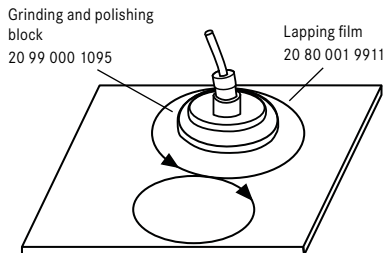


- Push cable gland over cable, position the guiding pin fully on the stripped cable. With the cable completely inserted, the fibre should protrude about 1 mm out of the guiding pin. To fix the cable in place, insert the clip in the hole and press on to the cable.



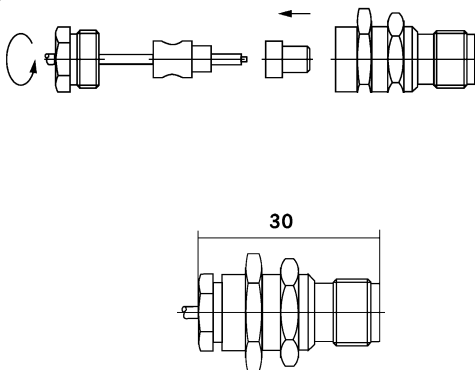
- Using the grinding and polishing block (5.5 mm thickness), polish the protruding fibre on a lapping film with 1000 grit and a hard surface, e.g. glass plate. The contact face can be repolished with a polishing paper 9 μ grit.

3



- For final assembly, the centring sleeve is placed on the guiding pin and inserted into the female housing. The cable gland is tightened.

4



3.8 F-TNC connector (male)

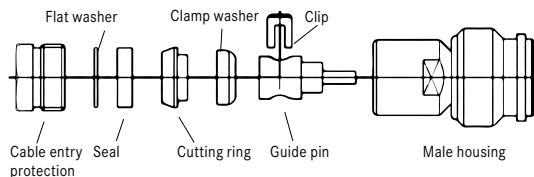
Part number: 20 10 001 6211

This connector is designed for 1 mm *POF* with 5.5 to 6.0 mm cable sheath.



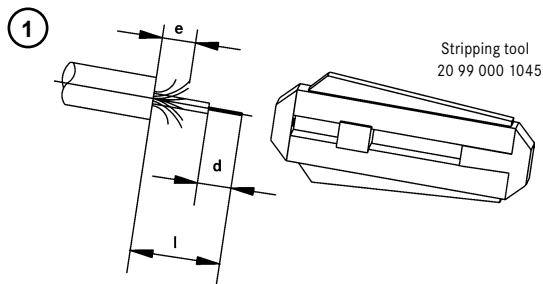
Figure XIII-10: F-BNC male

Description:

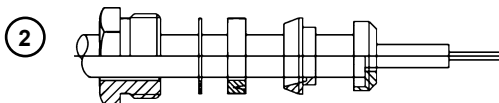


Assembly

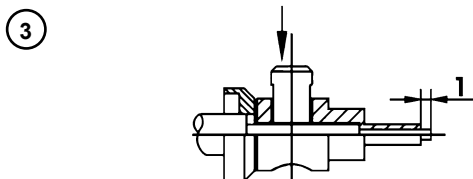
1. Use a cable knife to strip the FO cable to a length of 18 mm (L). Strip the strain relief (Kevlar) to a length of 7 mm (e). Strip the FO fibre cladding to a length of 7 mm (d).



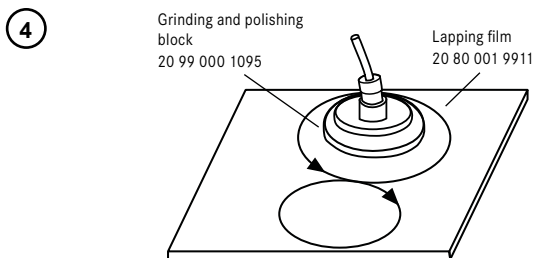
2. Push the cable gland, flat washer, seal, cutting ring over the cable sheath. Push the clamp washer over the fibre cladding.



3. Put the guiding pin on the fibre until it stops. To secure the position, press the clip over the cable sheath into the guiding pin. With the cable completely inserted, the fibre should protrude about 1 mm out of the guiding pin.



4. Using the grinding and polishing block (5.5 mm thickness), polish the protruding fibre on a lapping film with 1000 grit and a hard surface, e.g. glass plate. If necessary, repolish the contact face with a 9 μ grit polishing paper.



5. Clamp the Kevlar between clamp washer and cutting ring for final assembly. Slide the seal, flat washer and cable gland to the cutting ring. Attach the male housing and tighten the cable gland firmly.

3.9 F-ST connectors for glass fibre

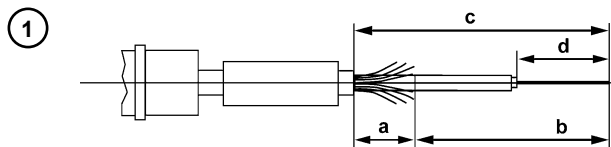
Part number: 20 10 125 2212



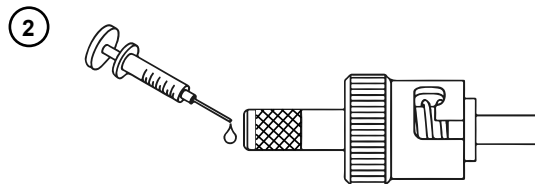
Figure VII-6: F-ST fibre optic connector

Assembly

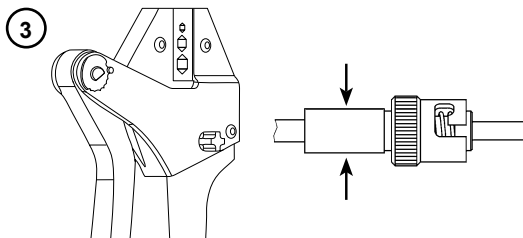
- Slide the bend protection and the crimp barrel on the cable. Strip the outer sheath to a length of 47 mm (c). Strip the strain relief to a length of 7 mm (a). Strip the compact wire to a length of 40 mm (b). Strip the primary protective layer of the fibre to a length of 28 mm (d).



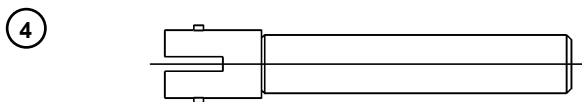
- Using a 1-ml syringe, inject 1.5 to 2 increments of adhesive into the connector. Clean fibre with alcohol. Insert fibre with cable into the connector. If necessary, turn this slightly. Push the crimp barrel onto the connector and crimp it with the hexagonal crimping tool 20 99 000 1031.



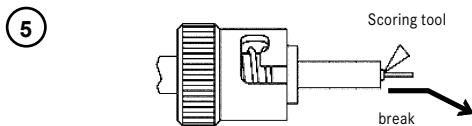
- Push the crimp ferrule onto the connector and fix it with the crimping tool 20 99 000 1031. Wrench size: 4.95 mm.



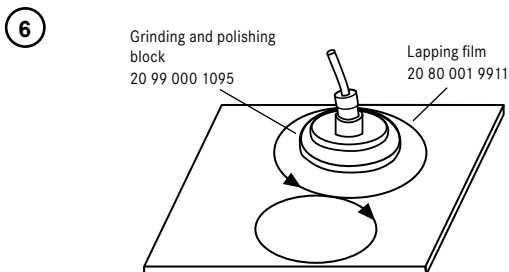
4. Mate the F-ST heating box adapter onto the connector.
Allow to harden for about 1/2 hour in the heating box.



5. Then, score the fibre carefully with a scoring tool. The protruding fibre is broken under tension and slight bending.



6. Using a grinding and polishing block, polish the contact face on a polishing paper with 9 μ grit and then repolish with polishing paper with 1 μ grit.



7. Check the quality of the face with a microscope at 200x magnification.

3.10 SC contacts for glass fibre

Part number: 20 10 125 5211

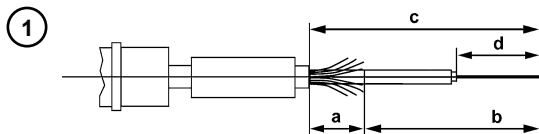
These contacts are designed for interior cabling 50/125 μm and 62.5/125 μm with 2.8 mm cable sheaths. After assembly, this contact can be assembled in the SC module from the Han-Modular® series or in the SC insert for the housing of size Han® 3 A.



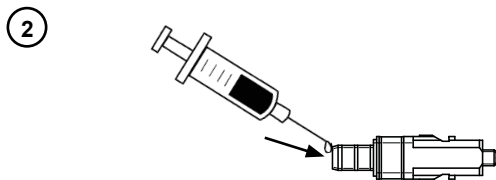
Figure XIII-15: SC contact

Assembly

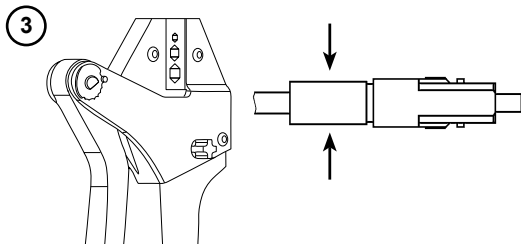
- Slide the bend protection and the crimp barrel on the cable. Strip the outer sheath to a length of 48 mm (c). Strip the strain relief to a length of 8 mm (a). Strip the compact wire to a length of 40 mm (b). Strip the primary protective layer of the fibre to a length of 29 mm (d).



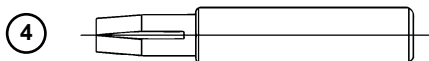
- Using a 1-ml syringe, inject 1.5 to 2 increments of adhesive into the connector. Clean fibre with alcohol. Insert fibre with cable into the connector. If necessary, turn this slightly. Push the crimp barrel onto the connector and crimp it with the hexagonal crimping tool for glass fibre 20 99 000 1031.



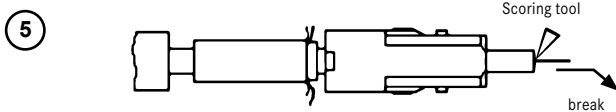
- Push the crimp ferrule onto the connector and fix it with the crimping tool 20 99 000 1031. Wrench size: 4.95 mm.



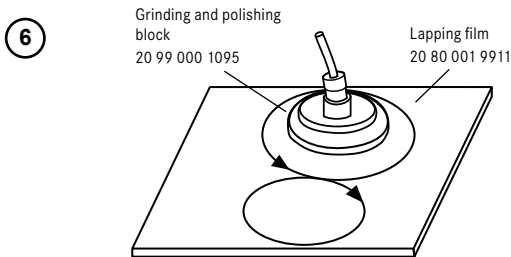
4. Mate the SC heating box adapter onto the connector. Allow the connectors to harden for about 1/2 hour in the heating box.



5. Then, score the fibre carefully with a scoring tool. The fibre is broken under tension and slight bending.



6. Using a grinding and polishing block, polish the contact face on a polishing paper with 9 μ grit and then repolish with polishing paper with 1 μ grit.



7. Check the quality of the face with a microscope at 200x magnification.

3.11 LC contact for GI fibre and single-mode fibres

Part numbers: 20 10 125 8211
 20 10 125 8212
 20 10 125 8220
 20 10 125 8221

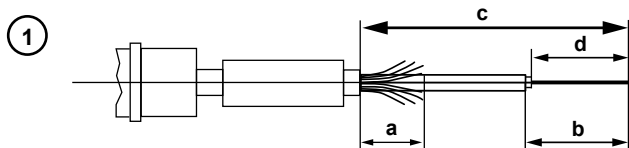
The LC contact is suitable for FO inside cables 50/125 μm and 62.5/125 μm with 2.8 or 3.0 mm cable sheath.



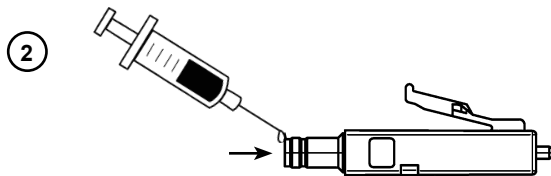
Figure XIII-16: LC contact

Assembly

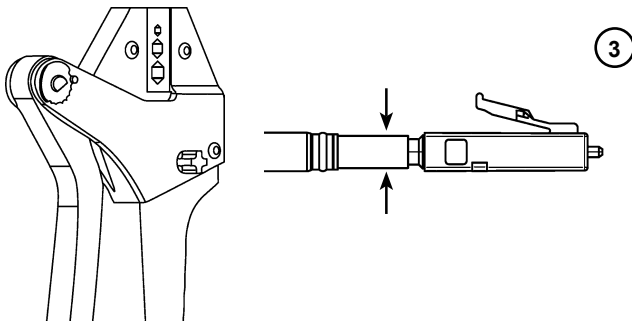
- Slide the bend protection and the crimp barrel on the cable. Strip the outer sheath to a length of 40 mm (c). Strip the strain relief to a length of 6.5 mm (a). Strip the secondary protective layer of the fibre to a length of 20 mm (b). Strip the primary protective layer of the fibre to a length of 19 mm (d).



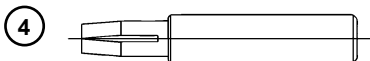
- Mate the heating box adapter onto the connector. Using a 1-ml syringe, inject 1.5 to 2 increments of adhesive into the connector. Clean fibre with alcohol. Insert fibre with cable into the connector. If necessary, slightly turn the connector.



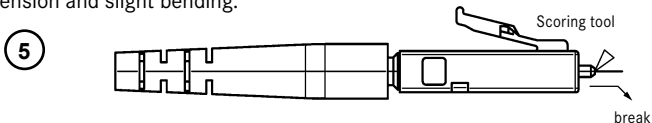
3. Push the crimp barrel onto the connector and crimp it with the hexagonal crimping tool 20 99 000 1031 for glass fibre (AF 3.2 mm).



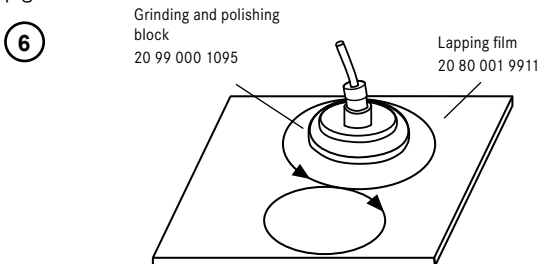
4. Allow the connectors to harden for about 1/2 hour in the heating box.



5. Then, score the fibre carefully with a scoring tool. The fibre is broken under tension and slight bending.



6. Using a grinding and polishing block, the contact face is polished on a polishing paper with 9 μ grit and then repolished with polishing paper with 1 μ grit.



7. Check the quality of the face with a microscope at 200x magnification.

4. FO contacts

The following pages describe the assembly of the FO contacts used at HARTING. The FO contacts lock into the insert after assembly. Therefore, both electrical and optical contacts can be used in a connector.

4.1 FO contacts for Han D[®] and Han DD[®] contact inserts

Part numbers:

20 10 001 32x1 for insert Han[®] R 15 and Han DD[®]

20 10 001 32x2 for insert Han[®] U and Han D[®]

20 10 001 32x3 for insert Han[®] 15D to Han[®] 25D

This FO contact is designed for 1 mm *POF* wire with 2.2 mm cable sheath.



Figure XIII-11: FO contacts for Han D[®] and Han DD[®]

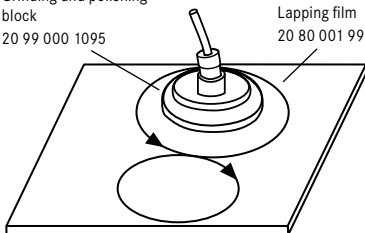
Assembly

- Optical fibre end face must be polished before the crimping the contacts. A polish tool and lapping film must be used with 1000 grit. A hard surface, e.g. a glass plate is best suited for this purpose. The fibre end face can be polished with a polishing paper 9 μ grit.

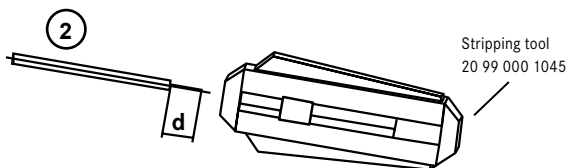
1

Grinding and polishing
block
20 99 000 1095

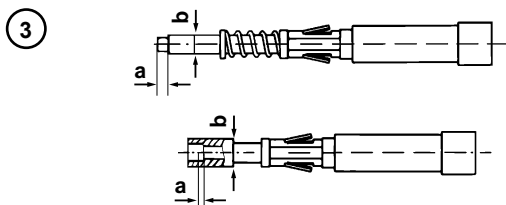
Lapping film
20 80 001 9911



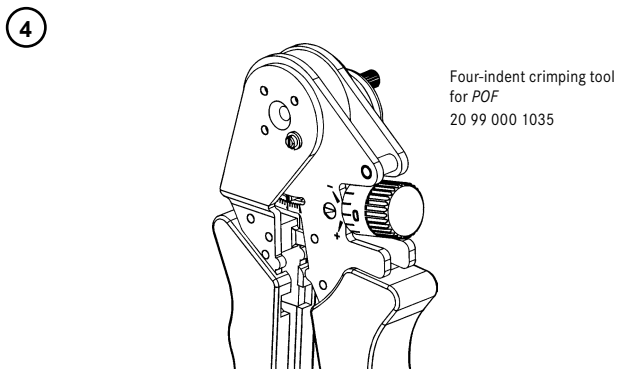
- Strip the FO cable to a length of 14 mm for the female contact and 19 mm for the male contact (d).



3. Position the contacts on the cable. With the cable completely inserted, the fibre should protrude about 1 mm out of the contact (a).



4. Use the four-indent crimping tool to crimp the FO fibre in the designated area of the contact tip (b). Setting of the crimping die with crimping tool closed for the male contact: \varnothing 1.48 mm, locator setting 1. For the female contact: \varnothing 1.48 mm, locator setting 2 (refer to operating instructions of the four-indent crimping tool). For the male contact, the fibre must be flush with the male tip. For the female contact, it must terminate with the female earth.



4.2 FO contacts for Han E® inserts

Part number: 20 10 001 33x1

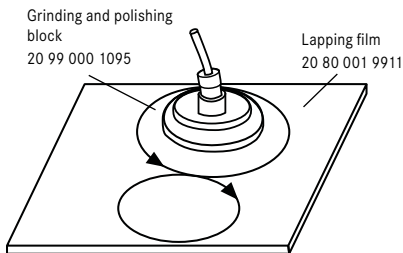
These FO contacts are designed for 1 mm POF wire with 2.2 mm cable sheath.



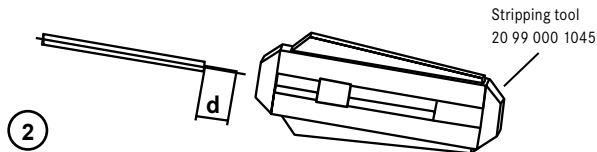
Figure XIII-12: FO contact for Han E®

- Optical fibre end face must be polished before the crimping the contacts. A polish tool and lapping film must be used with 1000 grit. A hard surface, e.g. a glass plate is best suited for this purpose. The contact face can be repolished with a polishing paper 9 μ grit.

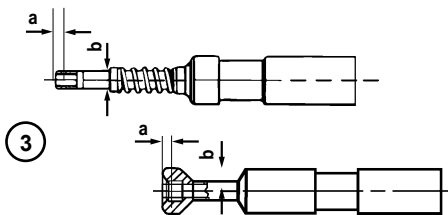
1



- Strip the FO cable to a length of 8 mm for the female contact and 19 mm for the male contact (d).



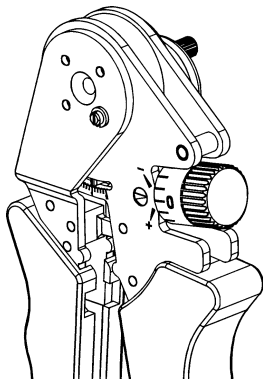
- Position the contacts on the cable. With the cable completely inserted, the fibre should protrude about 1 mm out of the contact (a).



- Use the four-indent crimping tool to crimp the FO fibre in the designated area of the contact tip (b). Set the crimp die with the crimping tool closed for the male contact: \varnothing 1.48 mm, locator setting 1.

For the female contact: \varnothing 1.48 mm, locator setting 2 (refer to operating instructions of the four-indent crimping tool). For the male contact, the fibre must be flush with the male tip. For the female contact, it must terminate with the female earth.

4



Four-indent crimping tool
for POF
20 99 000 1035

4.3 FO contacts for 1 mm POF in Han-Modular®

Part numbers:
20 10 001 4211
20 10 001 4221

These FO contacts are designed according to CECC 78 001-801 (formerly DIN 41 626, Part 3) for 1 mm POF with 2.2 mm cable sheath.

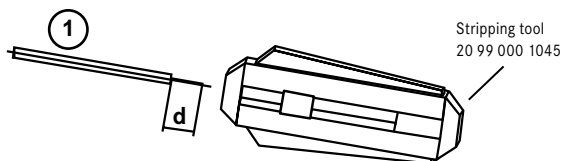


Figure XIII-13: FO contacts Han-Modular®

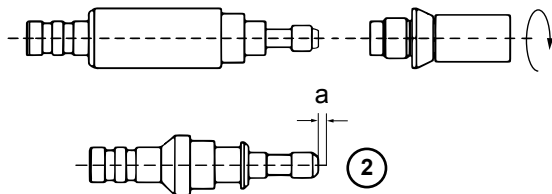
Assembly

FO contacts for single wire cable for mixed loading of connectors in accordance with DIN 41 612 (Gds A-M)/DIN 41 652 (D-Sub)

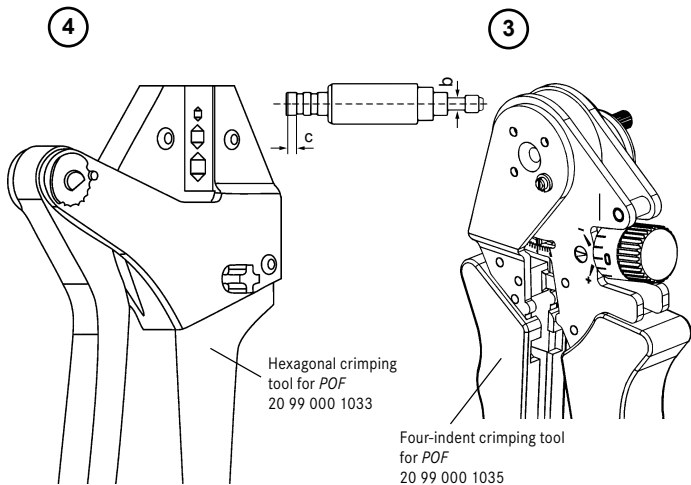
- Strip the FO fibre from the cable sheath. The *stripping length* for a male contact is at least 9 mm (d), for the female contact, it is at least 13 mm (d).



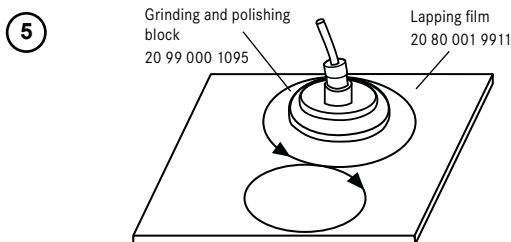
- Unscrew the female insert from the barrel. Position the contact on the cable. With the cable completely inserted, the fibre should protrude about 1 mm (a) out of the contact tip.



3. Use the four-indent crimping tool to crimp the FO fibre on the contact tip (b). Set the crimp die with crimping tool closed: \varnothing 1.8 mm, locator setting 3 (refer to operating instructions of four-indent crimping tool).
4. Crimp the FO contact using the hexagonal crimping tool (AF 3 mm) in the cable entry portion of the contact (c) over a length of approx. 4 mm.



5. Using the grinding and polishing block (7 mm thickness), polish the protruding fibre on a lapping film with grain size 1000 and a hard surface, e.g. glass plate. The contact face can be repolished with a polishing paper 9μ grit.



6. Screw the barrel on the female insert. Pay attention to the position of the locking ring!

4.4 FO contacts for GI fibre in Han-Modular®

These contacts are designed for indoor cable 50/125 μm and 62.5/125 μm with 2.8 mm cable sheath for assembly in the multi-contact module of the Han-Modular® series, using the following Insulator:

Part numbers:

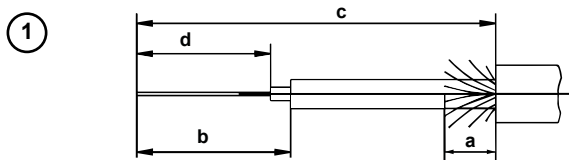
20 10 125 4212/20 10 125 4222



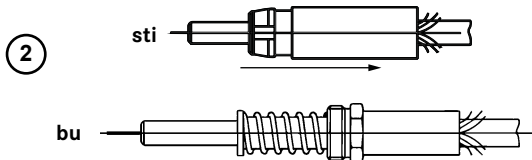
Figure XIII-14: Fibre optic contacts for Han-Modular®

Assembly:

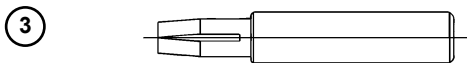
- Strip the outer sheath to a length of 22 mm (sti) and 32 mm (bu) (c). Strip the strain relief to a length of 5 mm (a). Strip the secondary protective layer to a length of 20 mm (b), strip the primary protective layer of the fibre to a length of 18 mm (d). The *stripping length* is the same for male and female contacts.



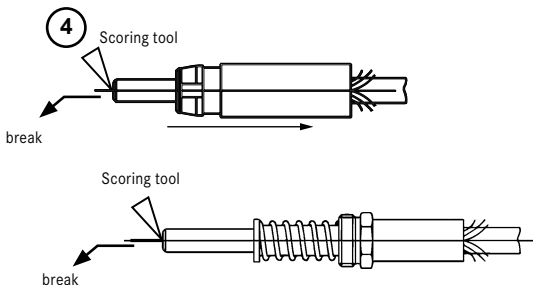
- Mate the F-ST heating box adapter onto the connector. Using a 1-ml syringe, inject 1.5 to 2 increments of adhesive into the connector. Clean fibre with alcohol. Apply adhesive to the strain relief (Kevlar fibre). Insert fibre with cable into the connector. If necessary, turn this slightly.



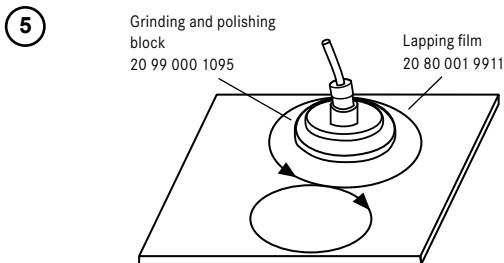
3. Allow the connectors to harden for about 1/2 hour in the heating box.



4. Then, score the fibre carefully with a scoring tool. The protruding fibre is broken under tension and slight bending.

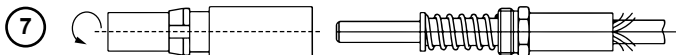


5. Using a grinding and polishing block, the contact face is polished on a polishing paper with 9μ grit and then repolished with polishing paper with 1μ grit.



6. Check the quality of the face with a microscope at 200x magnification.

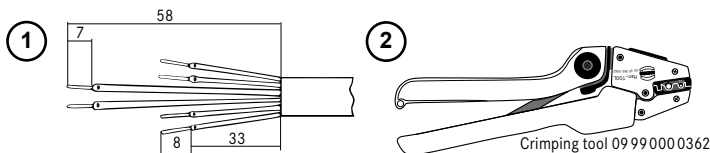
7. The barrel is then screwed on the female insert.



4.5 Han-Brid® FO contacts

Assembly

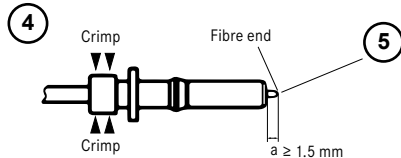
1. Dismantle and strip the cable according to the drawing. The stripped lengths of the two FO wires must be identical.
2. Crimp the electrical contacts. The crimping tool 09 99 000 0362 is designed for application of twisted HARTING crimp contacts with cross-section 1.5 mm^2 and Versatile Link FO crimp contacts.



3. Carefully push the crimp ring on the optical contact, so that it is flush with the contact end and there is a gap between crimp ring and contact flange. Push the optical contacts fully on the FO wire.



4. Fix the crimp ring using the Han Brid® crimping tool.



5. Shorten the protruding fibre end on the FO contact to a length of 1.5 mm. Polish the fibre end of the FO contacts with 600 grit lapping film and a polishing wheel. Polishing set part no.: 20 80 0001 9914.
6. The polishing process is finished when the face of the contact end is flush with the polishing fixture. Clean the contact end with a soft, lint-free cloth.

Crimping process

1. Check that the wire is stripped properly according to the assembly instructions, point ①.
2. Insert the contact into the crimp profile intended for the core type.
3. Use of the positioner the Han D® contact is locked properly.
4. Insert a stripped wire into the contact.
5. Crimp until the tool opens again.
6. Take out the crimped contact.

5. Operating instructions of HARTING four-indent crimping tool for 1 mm POF contacts

Part number: 20 99 000 1035

General

The HARTING four-indent crimping tool for 1 mm POF contacts is a crimping tool, manufactured according to the latest state-of-the-art and the recognised safety regulations. The hand crimping tool may only be used when functioning perfectly.

The crimping tool is used for crimping turned fibre optic contacts. The crimping tool must only be used for the purpose described in the operating instructions. The manufacturer is precluded from liability for damages that result from unauthorised alterations or improper use of this hand crimping tool.



Figure XIII-16: Four-indent crimping tool

Operation sequence

1. Crimp dimensional and locator setting for the contact to be crimped can be found in Table XII-1, p. 255.
2. The crimp dimension adjustment (crimp depth of the crimp pins) on control device.
3. Move locator bring by lateral lifting in the set, according to Matrix position.
Ensure that the contact holders are not pressed in and locked.
4. Press in the contact holder in the locator and lock by rotating through 90°.

5. Insert the FO contacts in the crimping position until it stops and close the crimping tool to the first locking step.
6. Insert the prepared cable into the FO contact in the crimping tool until it stops, apply light pressure to cable and connector against the stop and close crimping tool.
7. Remove the crimped FO contact from the crimping tool.
8. When selecting a new locator position, first unlock the contact holder and move to the starting position before making the new setting.

Crimp dimensional adjustment

The crimp dimensional adjustment (crimp depth of the crimp pins) is made as follows using the control device (using the adjusting wheel and adjusting screw).

Infeed movements

- clockwise = reducing the crimp dimension
- counterclockwise = increasing the crimp dimension

Infeed accuracy

- 1 increment on the adjusting wheel = 0.01 mm infeed
- 1 turn of the adjusting wheel = 0.2 mm infeed, can be read on the adjusting wheel
- 5 turns of the adjusting wheel = 1 mm infeed, read on the scale

Crimp dimensional check

The four-indent crimping tool is preset at the factory. Nevertheless, you should check the crimp dimension regularly. Please use the plug gauge \varnothing 2.0 mm (included with four-indent crimping tool) as described below.

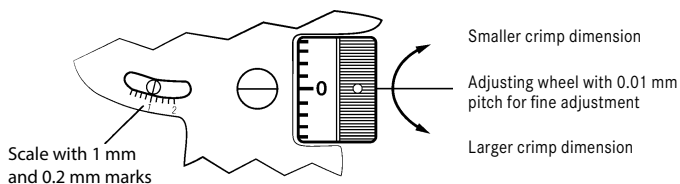


Figure XIII-17: Crimp dimensional adjustment

Use the adjusting wheel to adjust the dimension 2.0 mm on the scale of the fixed handle. The pitch on the adjusting wheel is set to zero and the crimping tool is closed (refer to Figure XIII-17). With this setting, the plug gauge \varnothing 2.0 mm must be able to move between the crimp pins without play.

If this is not the case, the fine adjustment of the rotary control can be used to determine the dimensional change (\pm) (to be applied as a micrometer screw). If, when checking the crimp, the four-indent crimping tool is outside of the ± 0.06 mm tolerance, the crimping tool manufacturer should be contacted for examination.

Table XIII-1: Adjustment recommendations

Type	Part no.	Locator setting	Crimp pin infeed
FO male insert 1 mm/2.2 mm POF for Han DD [®] , Han [®] K	20 10 001 3211	1	1.48 mm
FO male insert 1 mm/2.2 mm POF for Han D [®] , Han [®] U	20 10 001 3212	1	1.48 mm
FO male insert 1 mm/2.2 mm POF for Han E [®]	20 10 001 3311 20 10 001 3213	1 1	1.48 mm 1.48 mm
FO female insert 1 mm/2.2 mm POF for Han DD [®] , Han [®] K	20 10 001 3221	2	1.48 mm
FO female insert 1 mm/2.2 mm POF for Han D [®] , Han [®] U	20 10 001 3222	2	1.48 mm
FO female insert 1 mm/2.2 mm POF for Han E [®]	20 10 001 3321	2	1.48 mm
Fo cable end sleeve 1 mm/2.2 mm POF	20 10 001 3232	3	1.80 mm
FO male insert 1 mm/2.2 mm POF for Han [®] Multi Module	20 10 001 4211	3	1.80 mm
FO female insert 1 mm/2.2 mm POF for Han [®] Multi Module	20 10 001 4221	3	1.80 mm
F-ST connector 1 mm/2.2 mm POF	20 10 001 2211	3	2.0 mm
F-SMA connector 1 mm	20 10 001 1211	3	2.0 mm
F-SMA connector 1 mm	20 10 001 1221	3	2.0 mm
F-SMA connector 1 mm	20 10 001 1223	3	2.0 mm
F-SMA connector 1 mm	20 10 001 1241	3	2.0 mm
F-SMA connector 1 mm	20 10 001 1243	3	2.0 mm

6. Tool kit

The tools of the HARTING FO tool kit are used to assemble FO connectors on-site. These tools have been specially configured for working with fibre optics. They have been proven to work in the field. Detailed instructions for the assembly of different connectors are included with the assembly kit.

6.1 POF assembly kit with optical measuring devices

Part number: 20 99 000 3013



Depth: 360 mm
Width: 470 mm
Height: 170 mm

Figure XIII-18: Assembly kit 20 99 000 3013

The tools can be used to assemble FO connectors of the type F-SMA, ST and other FO contacts without gluing and polishing. The easy-to-handle measuring devices are intended for servicing purposes and checking the optical path. The assembly kit contains the complete set of tools and measuring devices required for assembly work.

XIII

The kit contains

Lower tray:

1. Documentation
2. Dry sanding paper, grit 1000 20 80 001 9911
3. Optical wattmeter OPM-1D
4. Adapter cable POF 1/2.2 F-ST/F-SMA
5. Adapter cable POF 1/2.2 F-ST/F-ST
6. Adapter cable POF 1/2.2 F-ST/F-SC
7. Adapter cable POF 1/2.2 F-ST/DIN 41626 female
8. Adapter cable POF 1/2.2 F-ST/DIN 41626 male
9. Adapter cable POF 1/2.2 F-ST/Han D female

10. Adapter cable *POF* 1/2.2 F-ST/Han D male
11. Adapter cable *POF* 1/2.2 F-ST/Han E female
12. Adapter cable *POF* 1/2.2 F-ST/Han E male

Upper tray:

13. Four-indent crimping tool for 1 mm *POF*20 99 000 1035
14. Hexagonal crimping tool for *POF*/SERCOS20 99 000 1033
15. Stripping tool
16. Combi-shears (all-purpose shears)
17. FO grinding surface, glass
18. Hinge box
 - a. F-ST adapter for OPM
 - b. Polish tool F-SMA20 99 000 1091
 - c. Polish tool DIN 4162620 99 000 1092
 - d. Polish tool *POF* cable 2.2.....20 99 000 1093
 - e. Polish tool F-ST.....20 99 000 1095
 - f. Polish tool F-SC *POF*.....20 99 000 1099
 - g. Polish tool for cable end sleeve20 99 000 1096
 - h. *POF* cutting tool
 - i. F-SMA coupling20 80 000 1071
 - j. F-ST coupling.....20 80 000 1021
 - k. F-SC coupling
 - l. F-SMA microscope adapter
 - m. F-ST/F-SC microscope adapter
 - n. Precision stripper 1.0 *POF*.....20 99 000 1045
 - o. Universal cutter with plastic handle
19. Microscope 30x
20. Fibre checker 650 nm

The assembly and operating instructions on the tools mentioned above are included.

6.2 FO measuring device kit

Part number: 20 99 000 3014



Depth: 360 mm
Width: 470 mm
Height: 170 mm

Figure XIII-19: FO measuring device kit 20 99 000 3014

Measuring optical outputs and attenuations in plastic (*POF*) and fibre optic cables at a wavelength of 650 nm and 850 nm.

Included in delivery:

Measuring cable for:

- 50 / 125 μm GI fibre, 1 m
- 200 / 230 μm SI fibre, 1 m
- 1 mm plastic fibre, 2 m

Measuring device adapter for:

- F-SMA termination
- F-ST termination

The kit contains

Lower tray:

1. Hinge box
 - a. F-ST adapter for OPM
 - b. F-LC adapter for OPM
 - c. Adapter 1.25 mm for fibre checker
 - d. F-SMA coupling
 - e. F-ST coupling
 - f. F-LC coupling
 - g. F-SC coupling
2. Optical wattmeter OPM-1D
3. Light source 850 nm
4. Fibre checker 650 nm
5. Adapter cable *POF* 1/2.2 F-ST/F-SMA
6. Adapter cable *POF* 1/2.2 F-ST/F-ST
7. Adapter cable *POF* 1/2.2 F-ST/F-SC
8. Adapter cable *POF* 1/2.2 F-ST/DIN 41626 female

9. Adapter cable *POF* 1/2.2 F-ST/DIN 41626 male
10. Adapter cable *POF* 1/2.2 F-ST/Han D female
11. Adapter cable *POF* 1/2.2 F-ST/Han D male
12. Adapter cable *POF* 1/2.2 F-ST/Han E female
13. Adapter cable *POF* 1/2.2 F-ST/Han E male

Upper tray:

14. One click cleaner 1.25 mm20 80 001 9920
15. One click cleaner 2.5 mm20 80 001 9921
16. Documentation
17. Adapter cable GI 50/125 F-LC/F-ST
18. Adapter cable GI 50/125 F-LC/DIN 41626 male
19. Adapter cable GI 50/125 F-LC/DIN 41626 female
20. Adapter cable GI 50/125 F-LC/F-SC
21. Adapter cable GI 50/125 F-LC/F-LC

The assembly and operating instructions on the tools mentioned above are included.

6.3 GI fibre assembly kit

Part number: 20 99 000 3015



Depth: 360 mm
Width: 470 mm
Height: 170 mm

XIII

Figure XIII-20: Assembly kit 20 99 000 3015

Tool kit for assembling FO connectors of type F-SMA, F-ST, F-SC, F-LC and DIN 41626 to FO cable with *graded index fibre* in adhesive technology.

The kit contains

Lower tray:

1. Heating box 24x FO / 240 V
 - a. Thermometer
 - b. Mains cable
2. Spray bottle for alcohol
3. Residual fibre container
4. Microscope 200x incl. 1.25 mm and 2.5 mm adapter
5. Optical wattmeter OPM-1D

Middle layer:

6. Hexagonal crimping tool 20 99 000 1031 for glass fibre
7. Combi-shears (all-purpose shears)
8. Microstrip FO
9. Stripping tool
10. Kevlar shears
11. Universal cutter with plastic handle
12. Light source 850 nm
13. Fibre checker
14. Fibre cleaving tool
15. Hinged box
 - a. F-ST adapter for OPM
 - b. F-LC adapter for OPM
 - c. Heating box adapter F-ST 20 99 002 1082
 - d. Heating box adapter F-SC / DIN 41626 20 99 003 1082
 - e. Heating box adapter F-LC 20 99 004 1082
 - f. Polish tool DIN 41626 20 99 000 1092
 - g. Polish tool F-ST 20 99 000 1095
 - h. Polish tool F-SC 20 99 000 1097
 - i. Polish tool F-LC 20 99 000 1090
 - j. Epo-Tek 360 (4g) 20 80 001 9902
 - k. F-ST coupling 20 80 000 1021
 - l. F-LC coupling
 - m. F-SC coupling
 - n. Disposable syringe 2 ml
 - o. Cannula for disposable syringe
 - p. Precision stripper 0.4 HCS
 - q. Adapter 1.25 mm for fibre checker

Upper tray:

- 16. Grinding surface made of rubber
- 17. Polishing foils 1 μm (5 sheets)20 80 001 9913
- 18. Polishing foils 9 μm (5 sheets)20 80 001 9912
- 19. One click cleaner 1.25 mm20 80 001 9920
- 20. One click cleaner 2.5 mm20 80 001 9921
- 21. Documentation
- 22. Adapter cable GI 50/125 F-LC/F-ST
- 23. Adapter cable GI 50/125 F-LC/DIN 41626 male
- 24. Adapter cable GI 50/125 F-LC/DIN 41626 female
- 25. Adapter cable GI 50/125 F-LC/F-SC
- 26. Adapter cable GI 50/125 F-LC/F-LC

The assembly and operating instructions on the tools mentioned above are included.

7. Overview of assembly

Table XIII-2: Overview of assembly

Part number	Description	Tools required for assembling HARTING FO standard contacts/connectors					
		Fibre stripper	Hexagonal crimping tool ¹⁾	Four-indent crimping tool	Polish tool	Adhesive	Grinding and polishing paper
20 10 001 1211	F-SMA connector, 1 mm/ 2.2 mm POF with hexagon nut	20 99 000 1045	20 99 000 1033	20 99 000 1035			20 80 001 9911
20 10 001 1212	F-SMA- Quick assembly connector 1 mm/2.2 mm POF with hexagon nut	20 99 000 1045			20 99 000 1091		20 80 001 9911
20 10 001 1213	F-SMA connector 1 mm/2.2 mm POF with knurled nut	20 99 000 1045	20 99 000 1033	20 99 000 1035	20 99 000 1091		20 80 001 9911
20 10 001 1215	F-SMA quick assembly connector 1 mm/2.2 mm POF with knurled nut	20 99 000 1045			20 99 000 1091		20 80 001 9911
20 10 001 1217	F-SMA quick assembly connector 1 mm/2.2 mm POF with knurled nut and bend protection	20 99 000 1045			20 99 000 1091		20 80 001 9911
20 10 001 1221	F-SMA connector POF/ SERCOS 6.0 with hex nut	20 99 000 1045	20 99 000 1033	20 99 000 1035	20 99 000 1091		20 80 001 9911
20 10 001 1223	F-SMA connector POF/ SERCOS 6.0 with knurled nut	20 99 000 1045	20 99 000 1033	20 99 000 1035	20 99 000 1091		20 80 001 9911

¹⁾ for POF = 20 99 000 1033/for glass fibre = 20 99 000 1031

Table XIII-2: Overview of assembly (continuation)

Part number	Description	Tools required for assembling HARTING FO standard contacts/connectors						
		Fibre stripper	Hexagonal crimping tool ¹⁾	Four-indent crimping tool	Polish tool	Adhesive	Grinding and polishing paper	
20 10 001 1241	F-SMA connector-POF/ SERCOS 3.6 with hex nut	20 99 000 1045	20 99 000 1033	20 99 000 1035	20 99 000 1091		20 80 001 9911	
20 10 001 1243	F-SMA connector-POF/ SERCOS 3.6 with knurled nut	20 99 000 1045	20 99 000 1033	20 99 000 1035	20 99 000 1091		20 80 001 9911	
20 10 001 2211	F-ST connector 1 mm/2.2 mm POF	20 99 000 1045	20 99 000 1033	20 99 000 1035	10 99 000 1095		20 80 001 9911	
20 10 001 2212	F-ST quick assembly connector 1 mm/2.2 mm POF	20 99 000 1045			20 99 000 1065		20 80 001 9911	
20 10 001 3211	FO male insert 1 mm/2.2 mm POF for Han DD®, Han® K	20 99 000 1045		20 99 000 1035	20 99 000 1093		20 80 001 9911	
20 10 001 3212	FO male insert 1 mm/2.2 mm POF for Han D®, Han® U	20 99 000 1045		20 99 000 1035	20 99 000 1093		20 80 001 9911	
20 10 001 3213	FO male insert 1 mm/2.2 mm POF for Han® 15 D	20 99 000 1045		20 99 000 1035	20 99 000 1093		20 80 001 9911	
20 10 001 3221	FO female insert 1 mm/2.2 mm POF for Han DD®, Han® K	20 99 000 1045		20 99 000 1035		20 80 001 9911		
20 10 001 3222	FO female insert 1 mm/2.2 mm POF for Han D®, Han® U	20 99 000 1045		20 99 000 1035	20 99 000 1093		20 80 001 9911	
20 10 001 3232	FO cable end sleeve 1 mm/2.2 mm POF	20 99 000 1045		20 99 000 1035	20 99 000 1096		20 80 001 9911	

¹⁾ for POF = 20 99 000 1033/for glass fibre = 20 99 000 1031

Table XIII-2: Overview of assembly (continuation)

Part number	Description	Tools required for assembling HARTING FO standard contacts/connectors					
		Fibre stripper	Hexagonal crimping tool ¹⁾	Four-indent crimping tool	Polish tool	Adhesive	Grinding and polishing paper
20 10 001 3311	FO male insert 1 mm/2.2 mm POF for Han E®	20 99 000 1045		20 99 000 1035	20 99 000 1093		20 80 001 9911
20 10 001 3321	FO female insert 1 mm/ 2.2 mm POF for Han E®	20 99 000 1045		20 99 000 1035	20 99 000 1093		20 80 001 9911
20 10 001 4211	FO male insert 1 mm/2.2 mm POF for Han® Multi Module	20 99 000 1045	20 99 000 1033	20 99 000 1035	20 99 000 1092		20 80 001 9911
20 10 001 4221	FO female insert, 1 mm/ 2.2 mm POF for Han® Multi Contact Module	20 99 000 1045	20 99 000 1033	20 99 000 1035	20 99 000 1092		20 80 001 9911
20 10 001 6211	F-TNC connector (male) 1 mm/2.2 mm POF	20 99 000 1045			20 99 000 1094		20 80 001 9911
20 10 001 6233	F-TNC built-in socket 1 mm/2.2 mm POF	20 99 000 1045		20 99 000 1031	20 99 000 1094		20 80 001 9911
20 10 001 7111	Versatile Link connector 1 mm/2.2 mm POF	20 99 000 1045			20 80 001 9914		
20 10 001 7112	Versatile Link connector 1 mm/2.2 mm POF, crimpless	20 99 000 1045			20 80 001 9914		
20 10 125 1212	F-SMA connector 125 GI	20 99 000 1046	20 99 000 1031		20 99 000 1091	20 80 001 9902	20 80 001 9912 20 80 001 9913
20 10 125 2212	F-ST connector 125 GI	20 99 000 1046	20 99 000 1031		20 99 000 1095	20 80 001 9902	20 80 001 9912 20 80 001 9913
20 10 125 4211	FO male insert (metal) 125 GI for Han® Multi Module	20 99 000 1046			20 99 000 1092	20 80 001 9902	20 80 001 9912 20 80 001 9913

1) for POF = 20 99 000 1033/for glass fibre = 20 99 000 1031

Table XIII-2: Overview of assembly (continuation)

Part number	Description	Tools required for assembling HARTING FO standard contacts/connectors						
		Fibre stripper	Hexagonal crimping tool ¹⁾	Four-indent crimping tool	Polish tool	Adhesive	Grinding and polishing paper	
20 10 125 4212	FO male insert (ceramic) 125 GI for Han® Multi Module	20 99 000 1046			20 99 000 1092	20 80 001 9902	20 80 001 9912 20 80 001 9913	
20 10 125 4221	FO female insert (metal) 125 GI for Han® Multi Module	20 99 000 1046			20 99 000 1092	20 80 001 9902	20 80 001 9912 20 80 001 9913	
20 10 125 4222	FO female insert, (ceramic) 125 GI for Han® Multi Contact Module	20 99 000 1046			20 99 000 1092	20 80 001 9902	20 80 001 9912 20 80 001 9913	
20 10 230 1212	F-SMA connector HCS, crimp	20 99 000 1041	20 99 000 1031		20 99 000 1091		20 80 001 9912 20 80 001 9913	
20 10 230 2212	F-ST connector HCS	20 99 000 1041	20 99 000 1031		20 99 000 1095	20 80 001 9902	20 80 001 9912 20 80 001 9913	
20 10 230 4211	FO male insert HCS for Han® Multi Module	20 99 000 1041			20 99 000 1092	20 80 001 9902	20 80 001 9912 20 80 001 9913	
20 10 230 4221	FO female insert HCS for Han® Multi Module	20 99 000 1041			20 99 000 1092	20 80 001 9902	20 80 001 9912 20 80 001 9913	
20 10 125 8211	LC contact for cable- ϕ 3 mm (Multi Mode) in the Han-Modular® LC Module	20 99 000 1046	20 99 000 1031				20 80 001 9912	
20 10 125 8220	LC contact for cable- ϕ \leq 3mm (Single-mode) in the Han-Modular® LC Module ¹⁾	20 99 000 1046	20 99 000 1031		20 99 000 1090	20 80 001 9902	20 80 001 9912	

¹⁾ for POF = 20 99 000 1033/for glass fibre = 20 99 000 1031

Table XIII-2: Overview of assembly (continuation)

Part number	Description	Tools required for assembling HARTING FO standard contacts/connectors					
		Fibre stripper	Hexagonal crimping tool ¹⁾	Four-indent crimping tool	Polish tool	Adhesive	Grinding and polishing paper
20 10 125 8212	LC contact for cable- $\phi \leq 2.8$ mm (Multi Mode) in the Han-Modular® LC Module	20 99 000 1046	20 99 000 1031		20 99 000 1090	20 80 001 9902	20 80 001 9912
20 10 125 8221	LC contact for cable- $\phi \leq 2.8$ mm (Single-mode) in the Han-Modular® LC Module	20 99 000 1046	20 99 000 1031		20 99 000 1090	20 80 001 9902	20 80 001 9912
20 10 125 5211	SC Contact for GI fibre 50/125 μm or 62.5/125 μm (ceramic ferrule) in Han-Modular® SC Module	20 99 000 1046	20 99 000 1031		20 99 000 1090	20 80 001 9902	20 80 001 9912
20 10 230 5211	SC contact for GI fibre (HCS®) 200/230 μm in Han-Modular® SC Module ¹⁾	20 99 000 1041	20 99 000 1033		20 99 000 1097		20 80 001 9911
20 10 001 5211	SC contact in crimping technology for 1 mm POF in the Han-Modular® SC Module	20 99 000 1045	20 99 000 1033		20 99 000 1097		20 80 001 9911
20 10 001 5217	SC contact in rapid termination technique for 1 mm POF in the Han-Modular® SC Module	20 99 000 1045	20 99 000 1033		20 99 000 1097		20 80 001 9911

¹⁾ for POF = 20 99 000 1033/for glass fibre = 20 99 000 1031

XIV. Attachment

Table of contents

1. Glossary.....	270
2. Overview of standards	272

1. Glossary

Terms	Explanation
Contact resistance	The electrical resistance in a plugged-in or switched contact pair, measured between the terminal points under specified measuring conditions.
Cross-section	Cross-section of a wire measured in mm ²
Current-carrying capacity	The current-carrying capacity is limited by the maximum temperature of the material of the contact insert and contacts including terminations.
Dispenser	Device for filling the solder pads of a printed circuit board with solder paste
Fluxer	A device for applying the flux
Graded index fibre	Multimode fibre with a parabolic refractive index of the core. This compensates for a delay difference between the fibre modes (modal dispersion).
HCS	Hard clad silicon. Plastic optical fibres where the optical core are made of quartz glass and the optical jacket are made of a special patented plastic layer. Optical core and optical jacket form an inseparable unit.
Hinged frame	2-piece mounting frame for holding modules from the Han-Modular® series
Lustre terminal	Used for connecting two or more electrical cables
Micro-section	Is taken to draw conclusions about specific characteristics of a product. The product is cut open and then sealed in.
Single-mode fibre	Also called mono-mode fibre. The light propagates in a single guided waveguide mode. Application for large transmission distances and/or bandwidths. Core diameter typically 3 – 9 µm.
PE panel (or earth panel)	Component for connecting the PE wire and to establish the PE connection to the housing
POF	Plastic optical fibres with typically 1mm core diameter. Easily wired in the field.

Terms	Explanation
Pull-out force	Force necessary to pull a connected wire from the termination point
Refractive index	Physical units in optics. It describes the refraction of an electromagnetic wave at the transition between two media. The refractive index is calculated as follows: $n = c_0 / c$ c_0 = Phase velocity of light in a vacuum c = Phase velocity in the medium
RoHS	Restriction of the Use of Certain Hazardous Substances // Directive 2002/95/EC
Gas-tight termination	The termination point has been connected so that air or gas mixtures from the outside have no influence.
SMT	Surface Mount Technology
Step index fibre	Multimode fibre with stepped refractive index profile. Refractive index is constant at the core and higher than the jacket. Delay differences occur between the fibre modes.
Stranded wire	Wire is composed of individual wire strands to achieve flexibility
Stripping length	Length of the stripped strand or wire end
THR	Through-Hole Reflow soldering technology
Tightening torque	Force with which a screw has to be tightened in order to achieve a proper connection
Wire ferrule	Sleeve for crimping for finely stranded wires

2. Overview of standards

Abbreviations

DIN	German Institute for Standardisation (German equivalent of ANSI)
EN	European standard
IEC	International Electrotechnical Commission
VDE	Association of German Electricians
ISO	International Organization for Standardization – ISO creates ISO standards that member countries are supposed to adopt without changes
DIN EN	German adoption of a European standard (EN)
DIN IEC	International standard, adopted as a German standard without changes
DIN VDE	DIN standard that is also a VDE regulation
CECC	Cenelec Electronic Components Committee
IPC	Association Connecting Electronic Industries

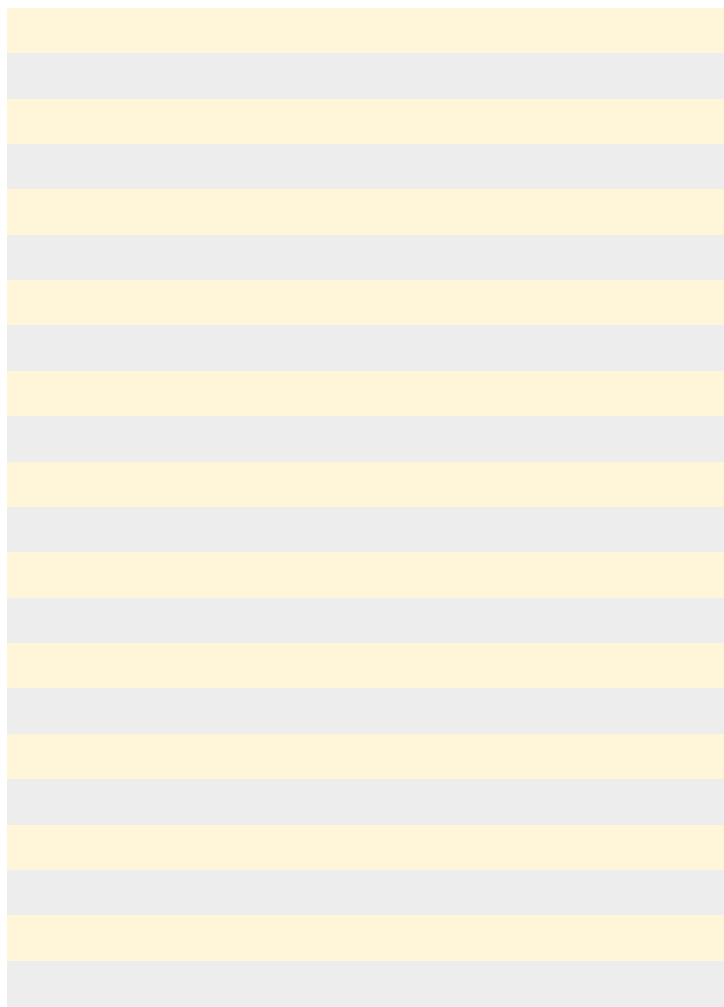
Cenelec	
CECC 75301-801	Design specification for multiple-pole, rectangular connectors with round, replaceable crimp contacts

DIN	
DIN 41611-4	Solderless electrical connections; clip connections; terminology, requirements, testing
DIN 41603-1	Connectors for frequencies for use with printed circuit boards: Generic specification: General requirements and guide for the preparation of detail specifications, with assessed quality
DIN 41652	Rack and panel connectors, trapezoidal, round contacts Ø 1 mm
DIN 46230	Cable shoes for solderless connections; pin type, without insulating sleeve, for copper wires
DIN 46330	Short Faston sleeves without insulating sleeve for 2.4 width connector
DIN ISO 857-2-03	Welding and related processes: terms Part 2: Soft and hard soldering and related terms
DIN EN	
DIN EN 175301-801	Design specification: multiple-pole, rectangular connectors with round, replaceable crimp contacts
DIN EN 50173	Information technology – Generic cabling systems
DIN EN 60068-2-69	Environmental testing: Solderability testing of electronic components and printed boards by the wetting balance
DIN EN 60204-1	Safety of machinery – Electrical equipment of machines – Part 1: General
DIN EN 60352-1	Solderless connections – Part 1: Wrapped connections; general requirements, test methods and usage notes
DIN EN 60352-2	Solder-free connections – Part 2: Crimp connections; general requirements, testing methods and usage notes
DIN EN 60352-3	Solder-free electrical connections – Part 3: general requirements, testing methods and usage notes
DIN EN 60352-4	Solder-free electrical connections – Part 4: general requirements, testing methods and usage notes

DIN EN	
DIN EN 60352-5	Solder-free electrical connections – Part 5: press-in connections – general requirements, testing methods and usage notes
DIN EN 60352-7	Solder-free electrical connections – Part 7: spring clamp connections general requirements, testing methods and usage notes
DIN EN 60603-13	Connectors for frequencies below 3 MHz for use with printed boards – Part 13: Detail specification for two-part connectors of assessed quality, for printed boards for basic grid of 2.54 mm (0.1 in), with free connectors for non-accessible insulation displacement terminations (ID)
DIN EN 60603-7	Connectors for electronic equipment – Part 7: Detail specification for unshielded, free and fixed connectors, 8 poles (IEC 48B / 1746 / CDV:2007)
DIN EN 60999-1	Connecting material – Electrical copper wires; Safety requirements for screw-type and screwless termination points – Part 1: General requirements and particular requirements for termination points for wires 0.2 mm ² to 35 mm ²
DIN EN 60999-2	Connecting material – Electrical copper wires; Safety requirements for screw-type and no-screw termination points – Part 2: General requirements and particular requirements for termination points for wires 35 mm ² to 300 mm ²
DIN EN 61984	Connectors – Safety requirements and tests
DIN VDE	
DIN VDE 0100-410	Low-voltage electrical installations – Parts 4-4.1: Protection measures – Protection against electric shock

IEC	
IEC 60603-2	Connectors for frequencies below 3 MHz for use with printed boards - Part 2: Detail specification for two-part connectors with assessed quality, for printed boards, for basic grid of 2,54 mm (0,1 in) with common mounting features
IEC 60807	Rectangular connectors for frequencies below 3 MHz; Part 1: Generic specification; general requirements
IEC 61076-4-107	Connectors for electronic equipment - Part 4-107: Printed board connectors with assessed quality - Detail specification for shielded two-part connectors having a basic grid of 2,0 mm, fixed part with solder and press-in terminations for printed boards, free part with non-accessible insulation displacement and crimp terminations
ISO/IEC 11801	Information technology – Generic cabling for customer premises
IEC 60068-2-69	Environmental testing: Solderability testing of electronic components and printed boards
IEC 60228	Conductors of insulated cables
IPC	
IPC-A-610	Acceptability of Electronic Assemblies
IPC/JEDEC J-STD-020	Moisture/Reflow Sensitivity Classification for Nonhermetic Surface Mount Devices
IPC/JEDEC J-STD-033	Handling, Packing, Shipping and Use of Moisture, Reflow, and Process Sensitive Devices
IPC EIA/JEDEC-J-STD-075	Classification of Passive and Solid State Devices for Assembly Processes
VDE	
VDE 0100-520	Low-voltage electrical installations - Part 5: Selection and setting up of electrical equipment - Chapter 52: Wiring systems
VDE 0295 (DIN EN IEC 60228)	Conductors of insulated cables
VDE 0627/DIN EN 61984	Connectors – Safety requirements and tests

Notes



XIV



Pushing Performance
Since 1945

www.HARTING.com



Pushing Performance
Since 1945

HARTING.com –
the gateway to your
country website.
